

**PT109-A - 2.4M WHEELCHAIR
INCLUSIVE PICNIC TABLE (INSTALLED)**
Installation Instructions

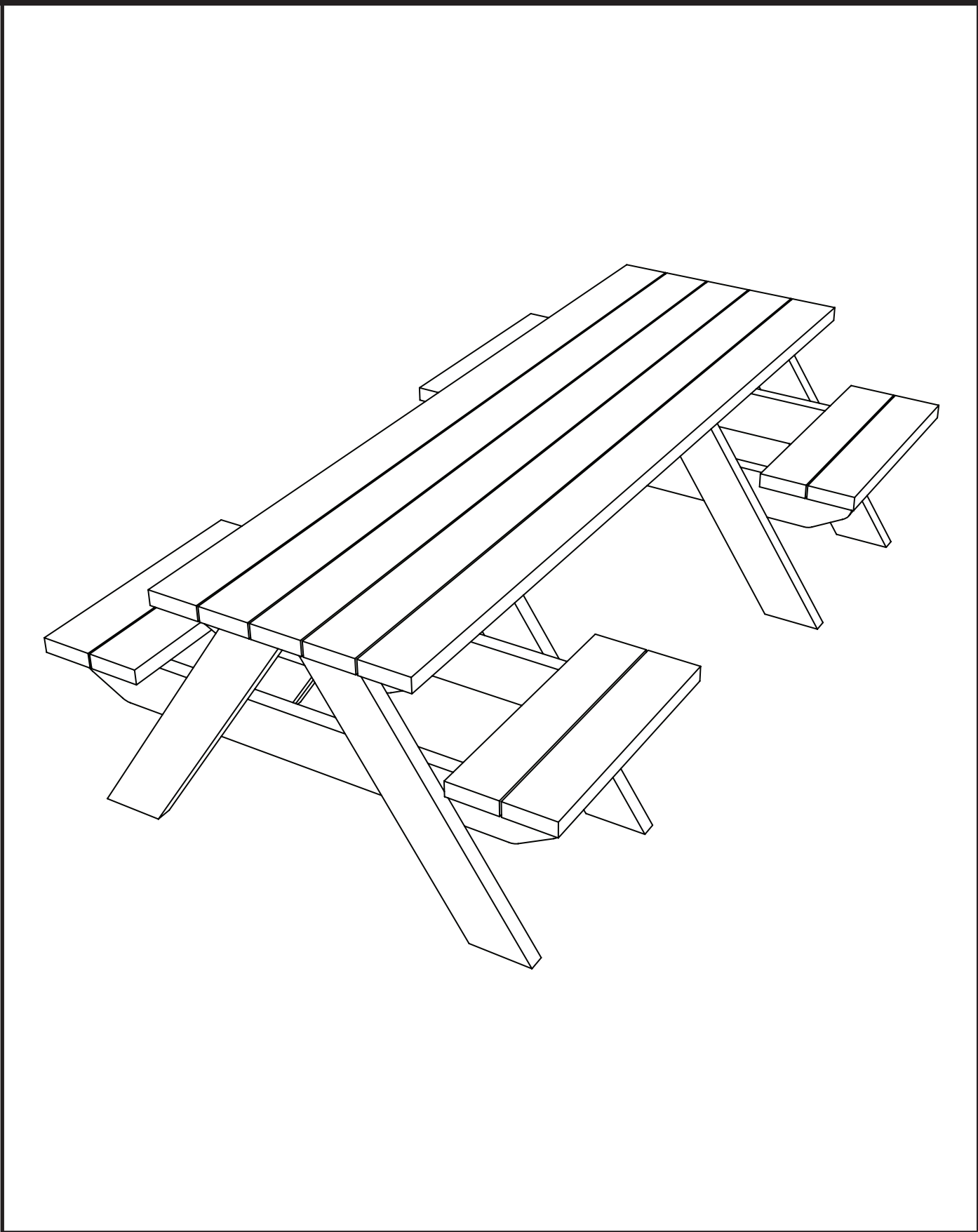

PT109-A - 2.4M WHEELCHAIR INCLUSIVE PICNIC TABLE (INSTALLED) Installation Instructions

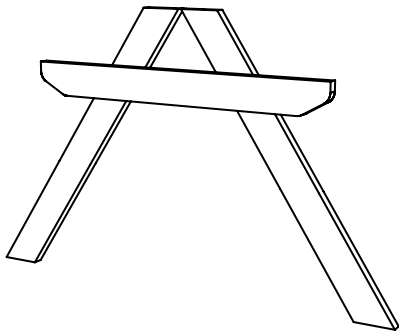

x4

TABLE LEGS

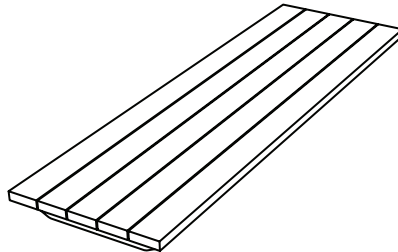

x1

2.4M TABLE TOP



x8

SEAT TIMBERS

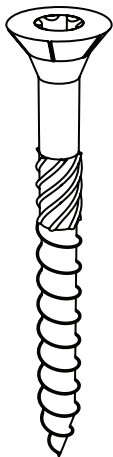

x48

M8X80CSK

TOOLS REQUIRED

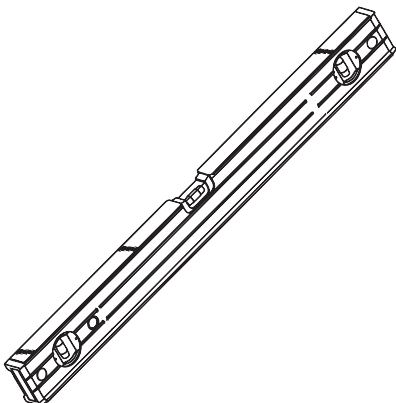

FOUNDATION DETAILS

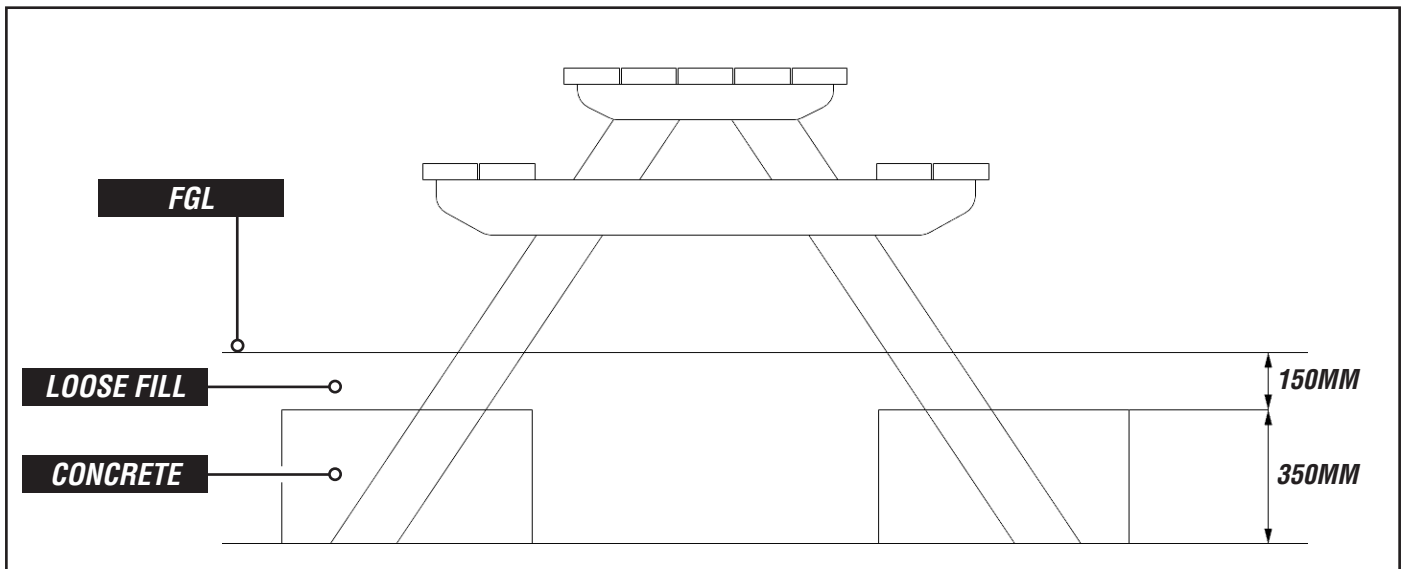
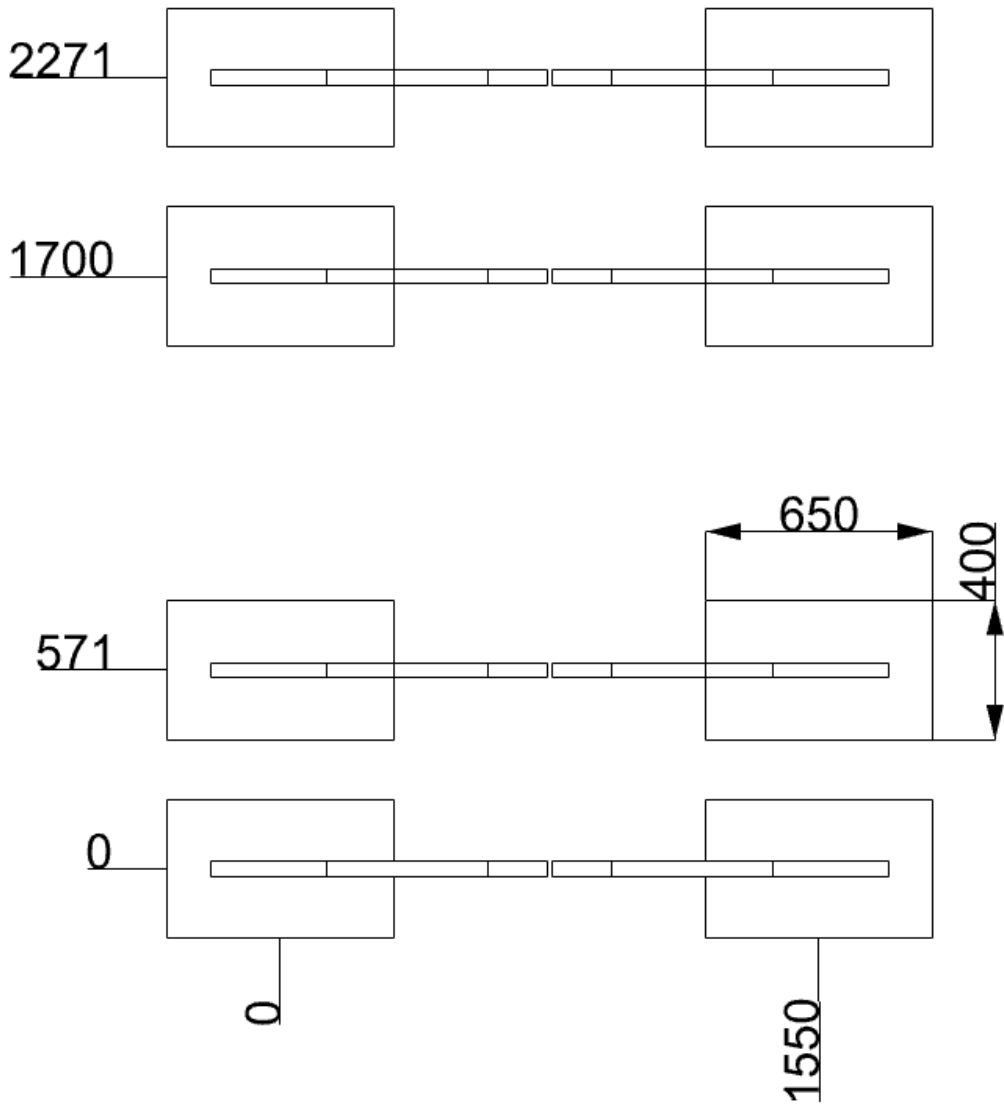

INSTALLATION INSTRUCTIONS

1

FIX TABLE TOP TO TABLE LEGS

USING M8X80 SCREWS [X16] - ENSURE LEGS SIT ON THE INSIDE OF THE TABLE TOP SUPPORTS

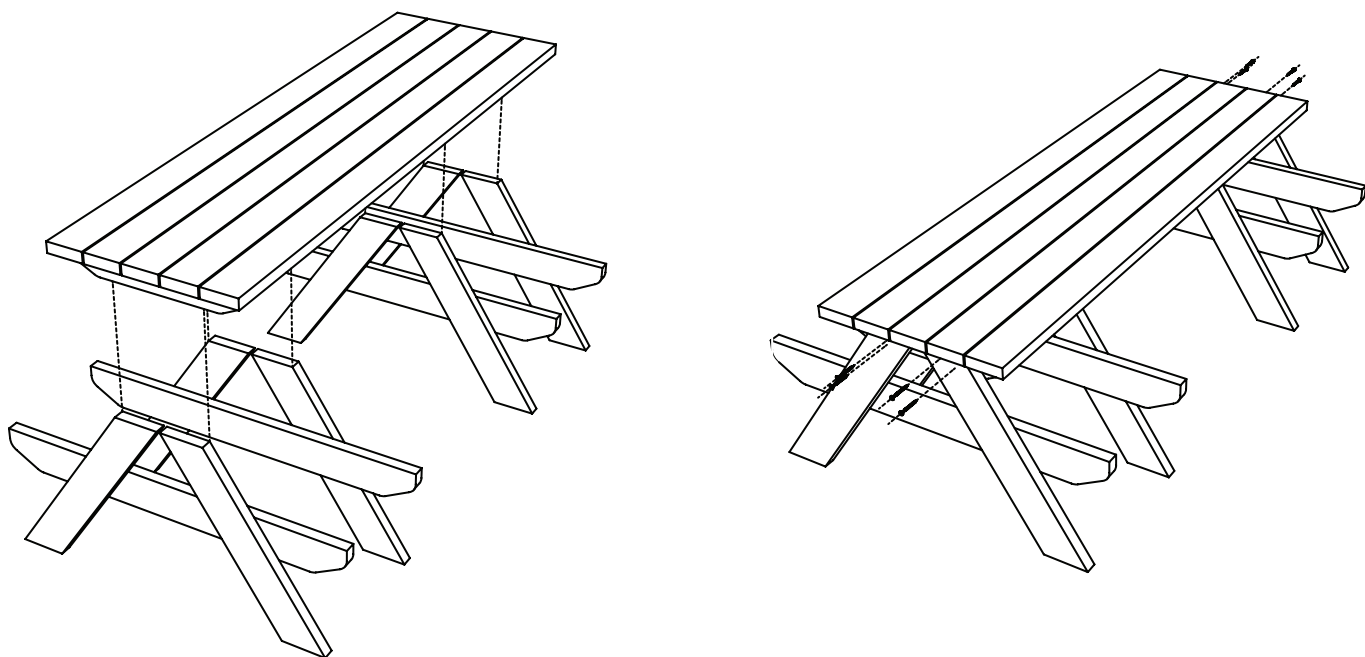

2

FIX SEATING TIMBERS TO TABLE TOP

USING M8X80 SCREWS [X32]

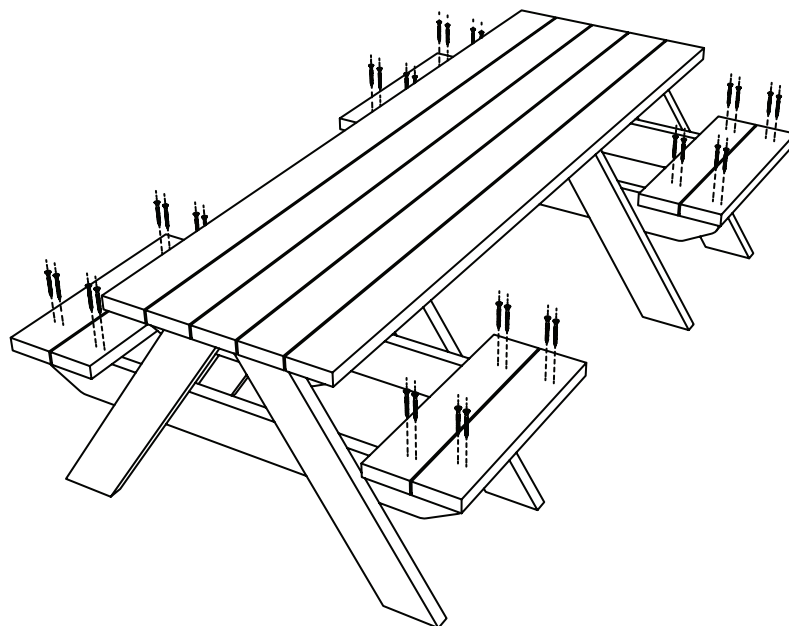

INSTALLATION INSTRUCTIONS

3

SECURE INTO THE GROUND
USING FOUNDATION DETAILS ON PAGE 3

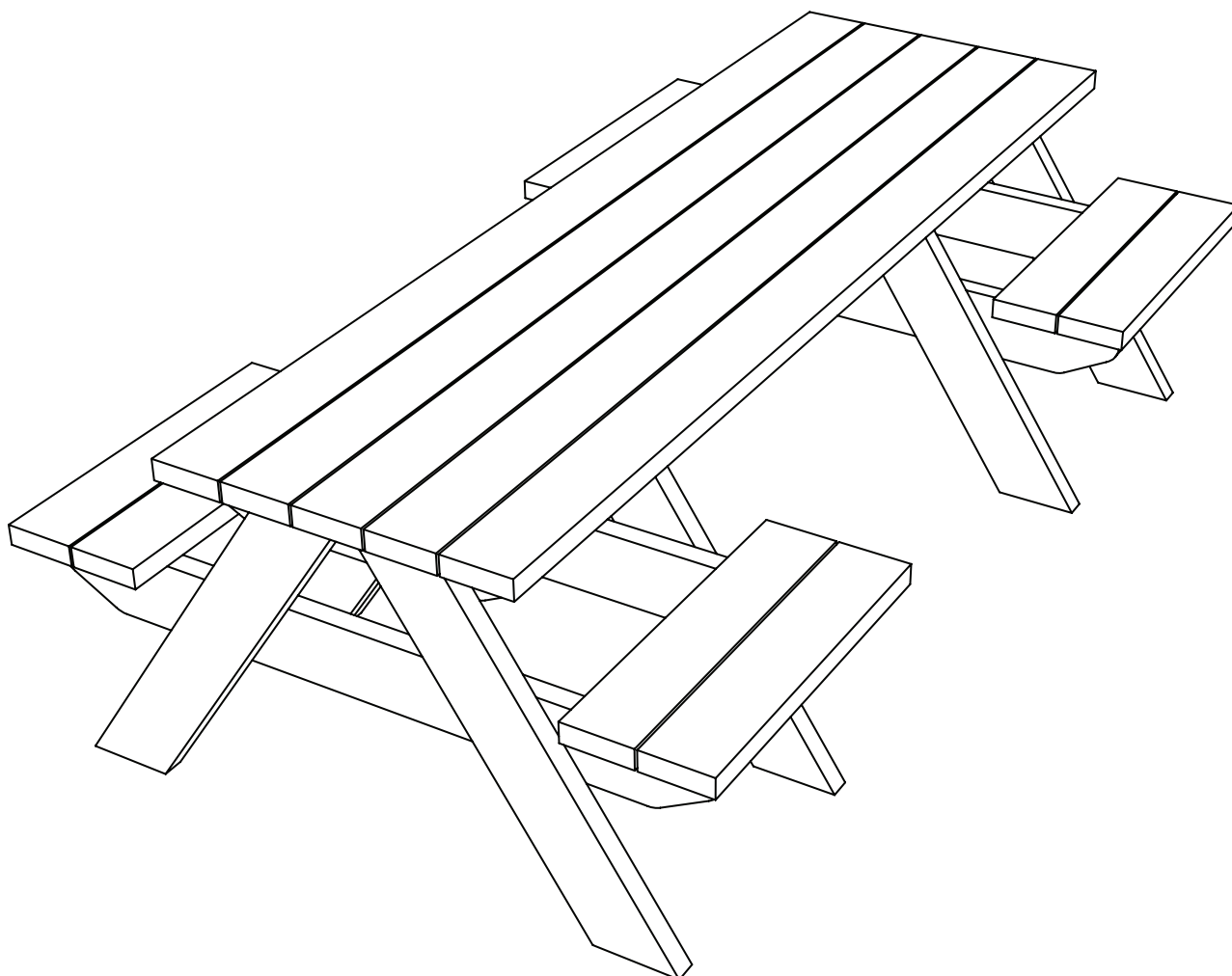

ADDITIONAL DIMENSIONS

