

# **ALPHABET SLIDER**

## **Installation Instructions**

**creative  
play**

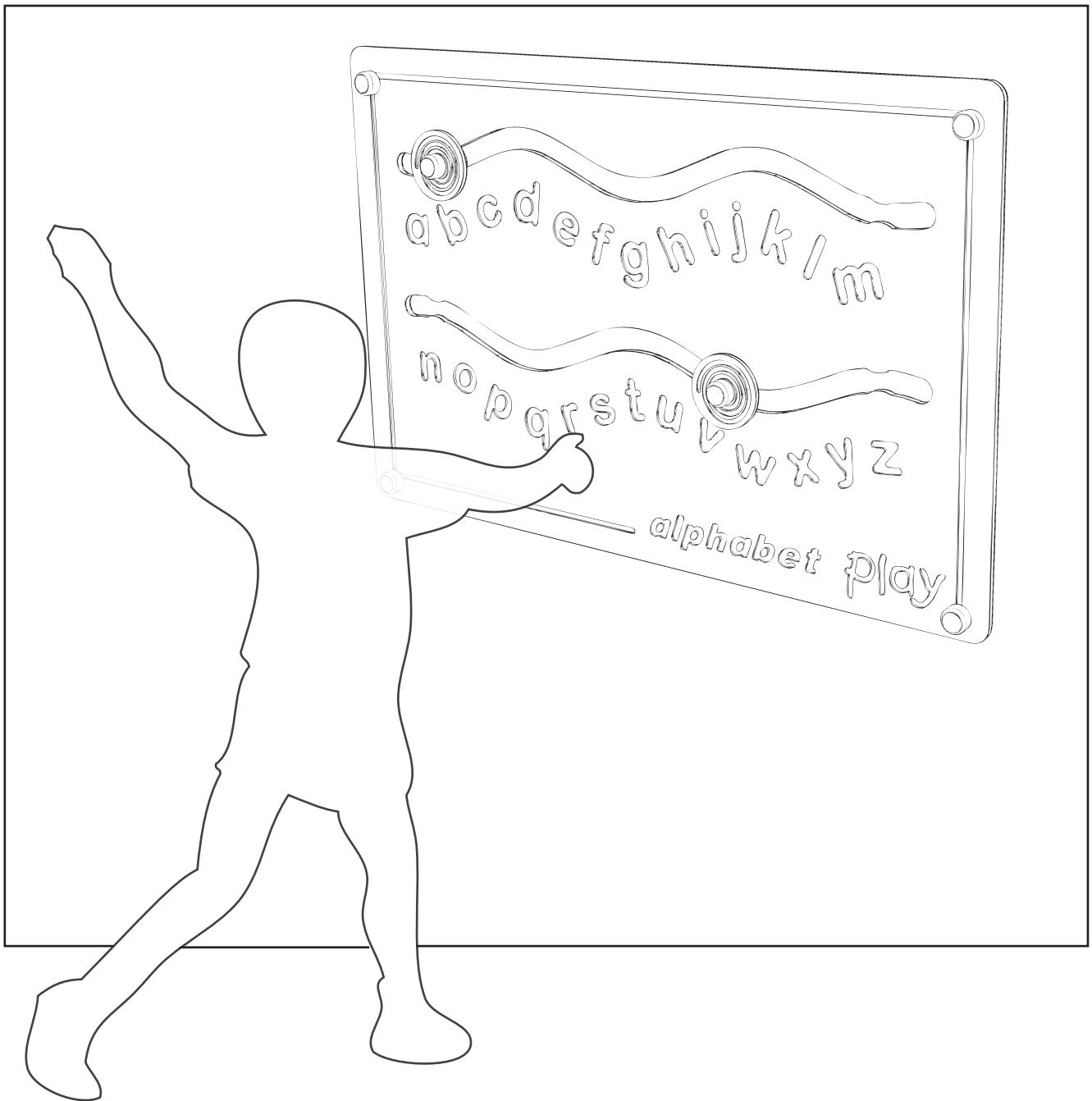

# PARTS required

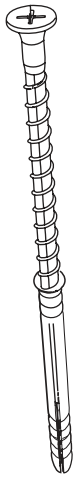
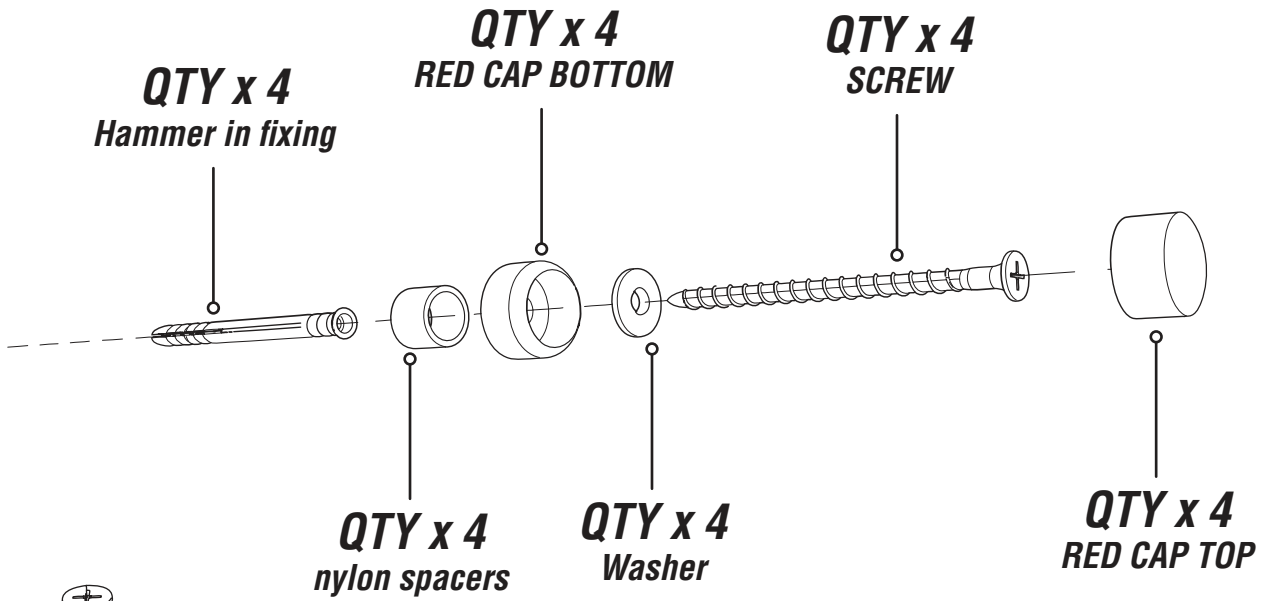

## NOTES:

The Hammer in fixing includes the screw

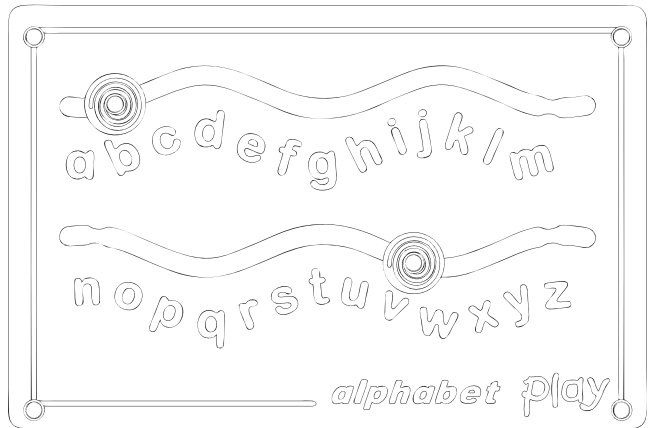

**x1 Alphabet board**

# TOOLS required

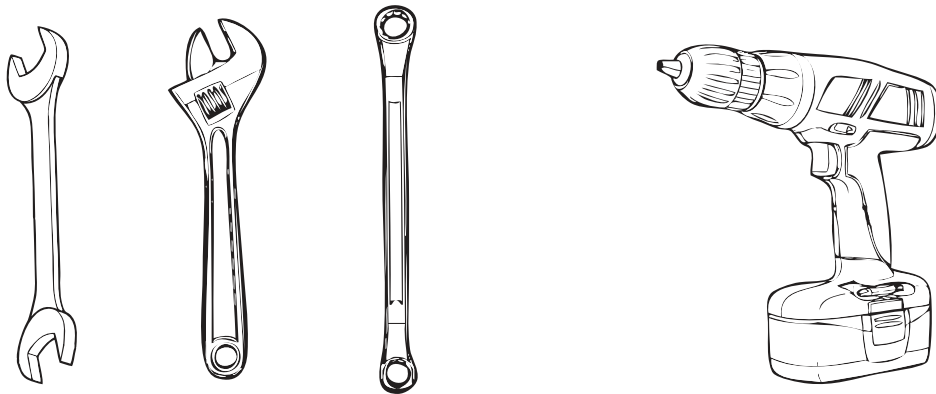

# Installation Instructions

---

**1**

## **Attach the ALPHABET BOARD to the WALL**

*Using M12 CUP HAMMER IN FIXING / SPACERS / SCREWS / END CAPS*

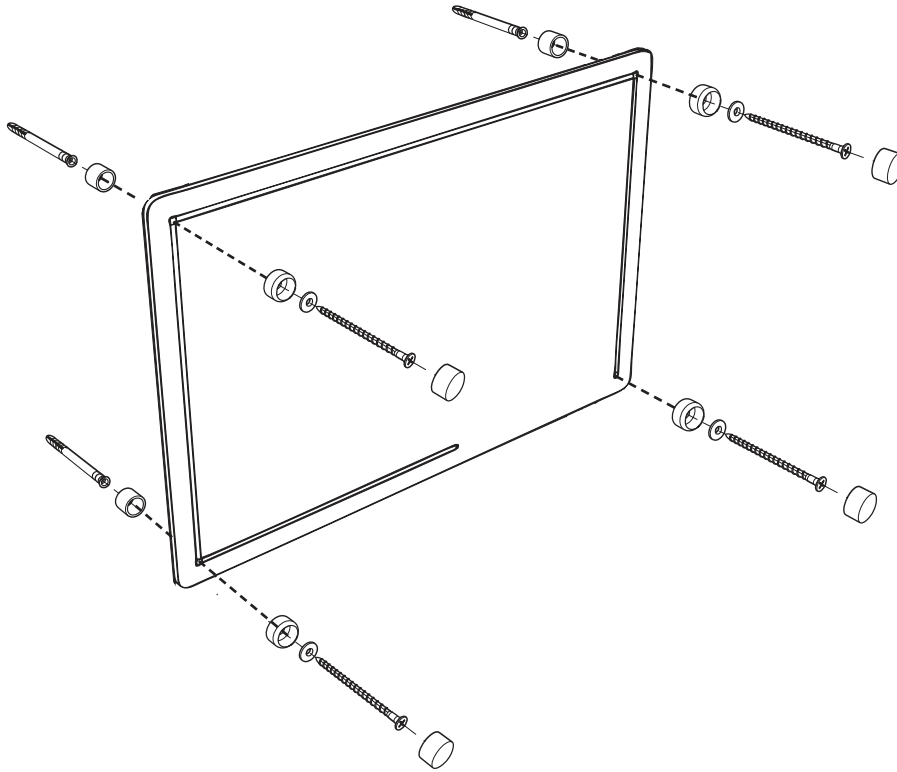

# ***Additional Dimensions***

---

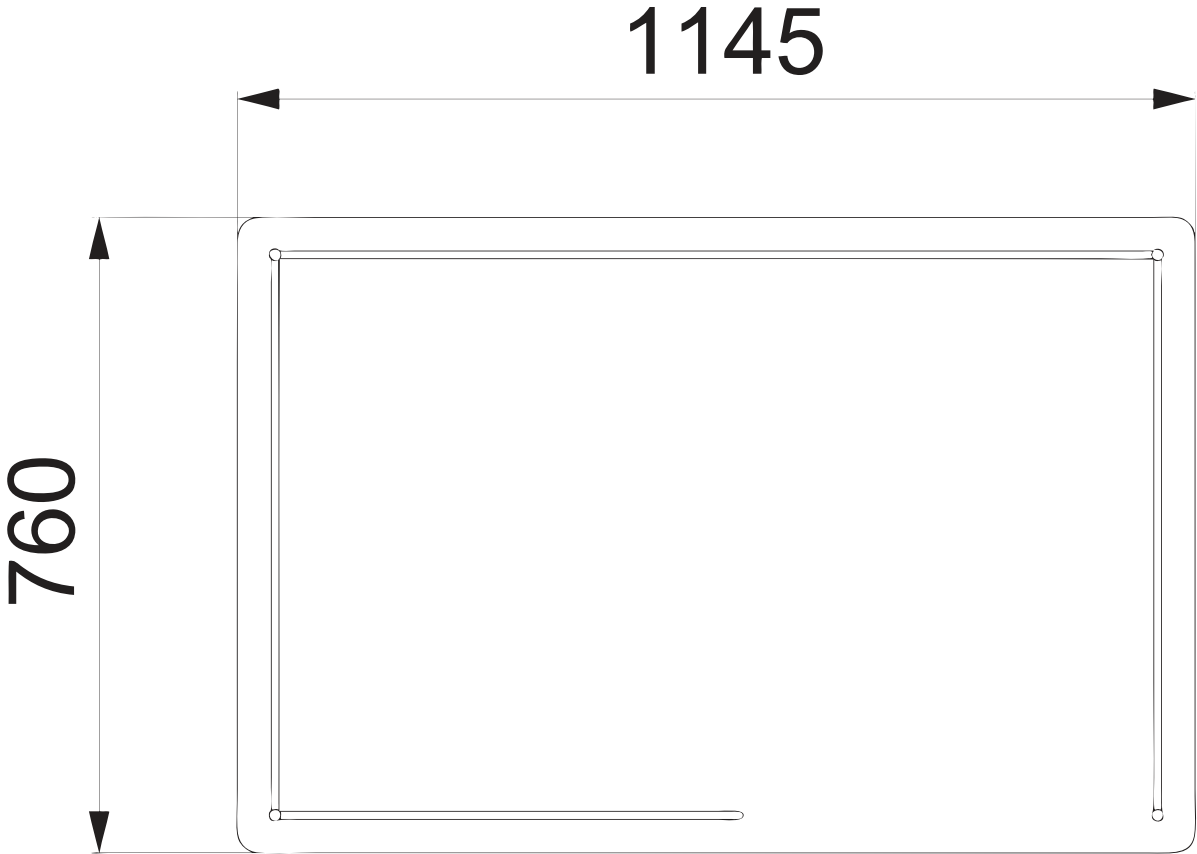

# OPTION for POSTS

## PARTS required



**x4** (M12 120 cup square hex)

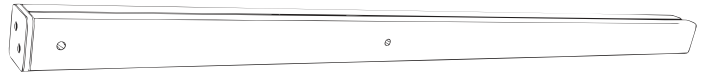

**PB1** QTY x 2  
(90mm x 90mm)



**x4** (M12 Nylocs)



**x4** (End Caps)

## Installation Instructions

**1**

**Attach the ALPHABET BOARD to the PB1 timbers**

Using M12 CUP SQUARE BOLTS / NYLOCS / END CAPS

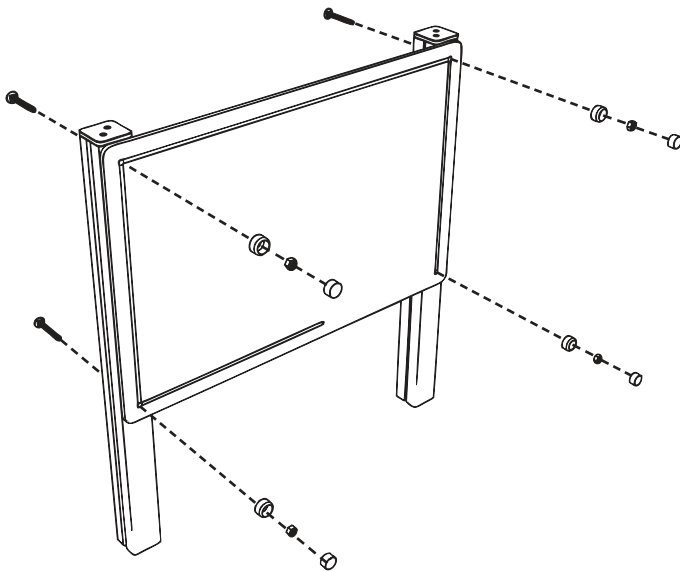

### NOTES:

RED END CAP MUST BE POSITIONED AT THE FRONT of the panel

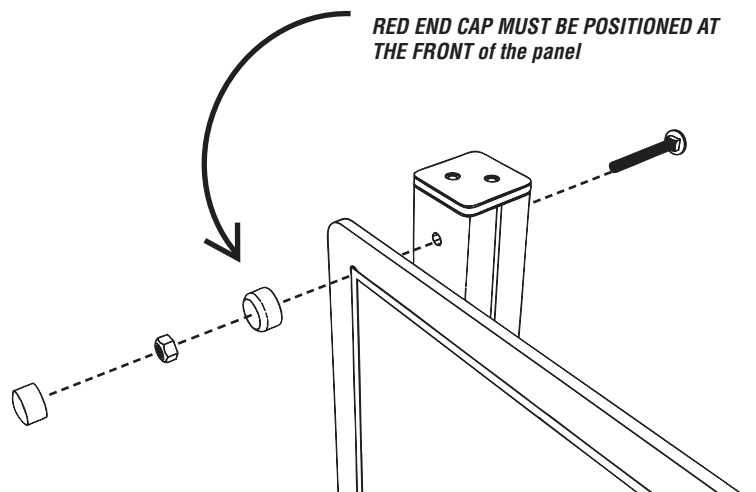

# Foundation Details

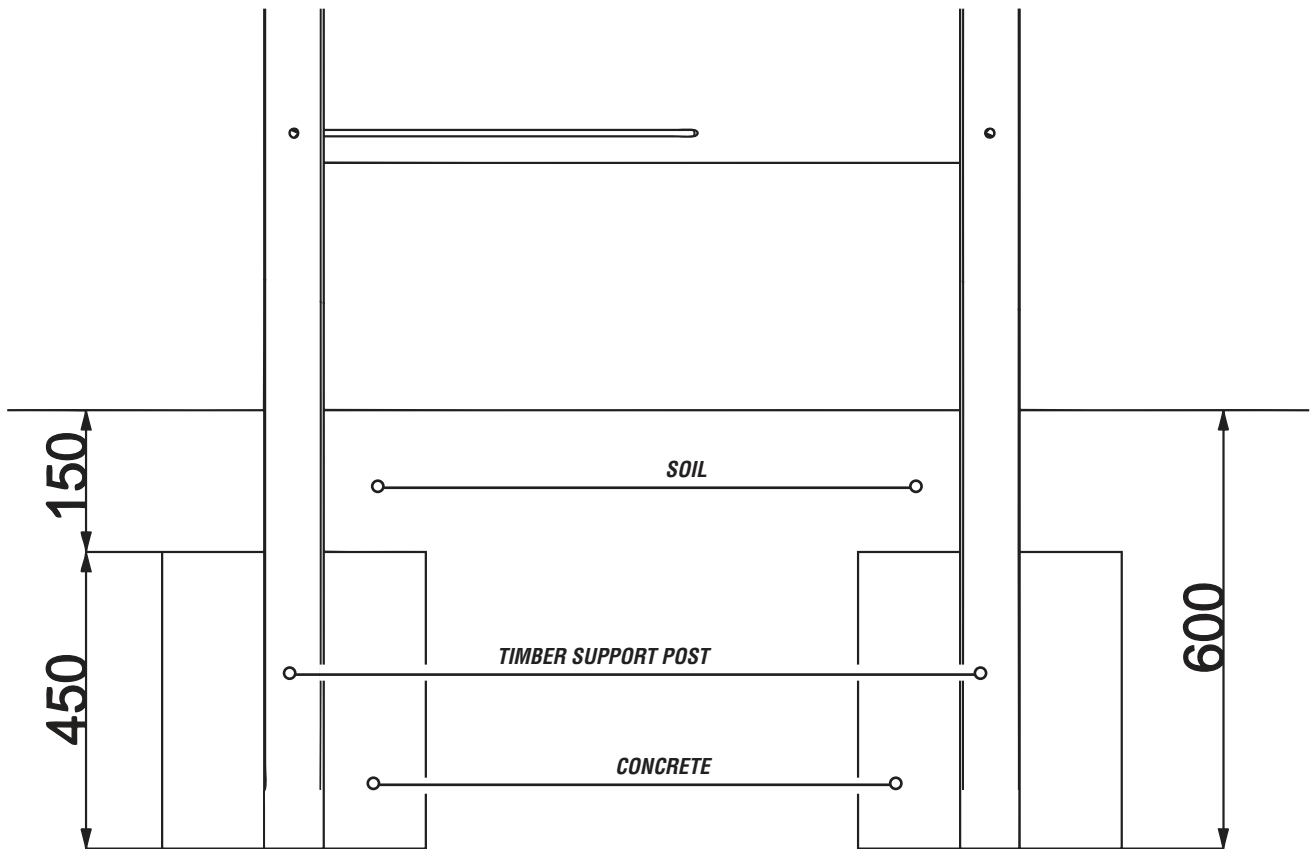
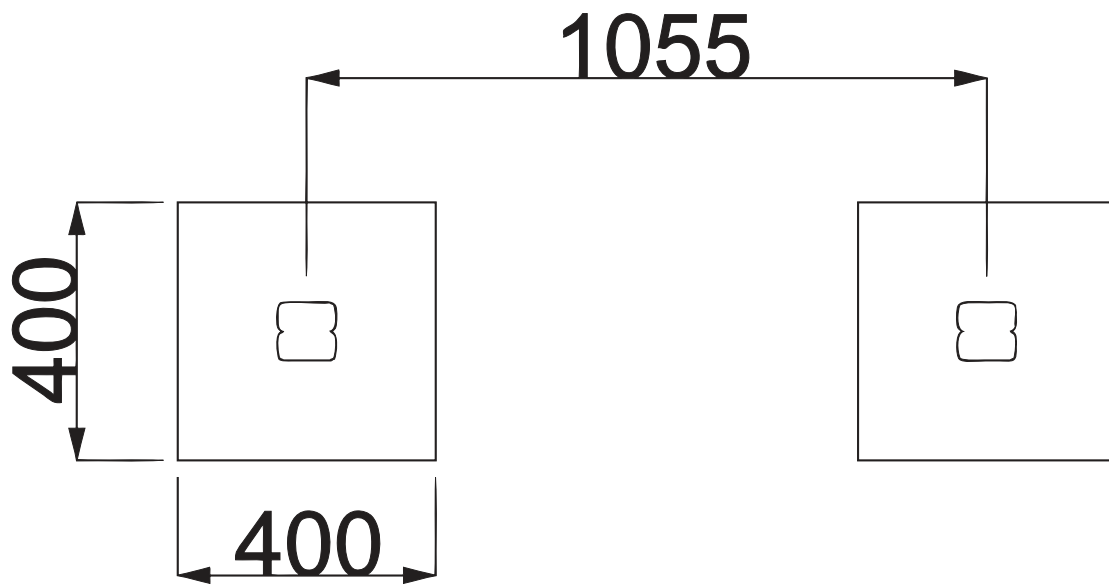

# Additional Dimensions

---

