

SPINNER WITH SEATING

Installation Instructions

**creative
play**

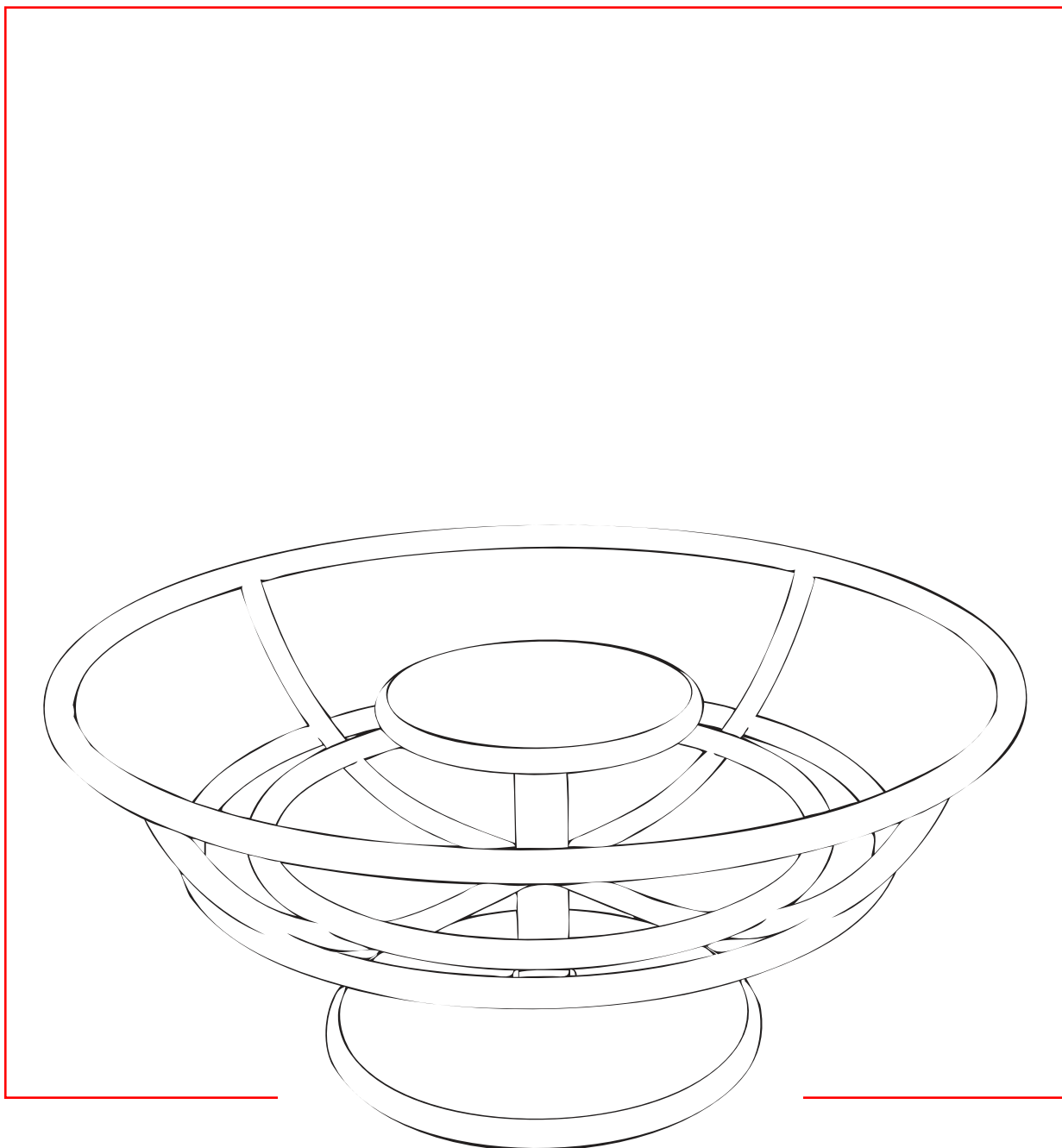

PARTS required

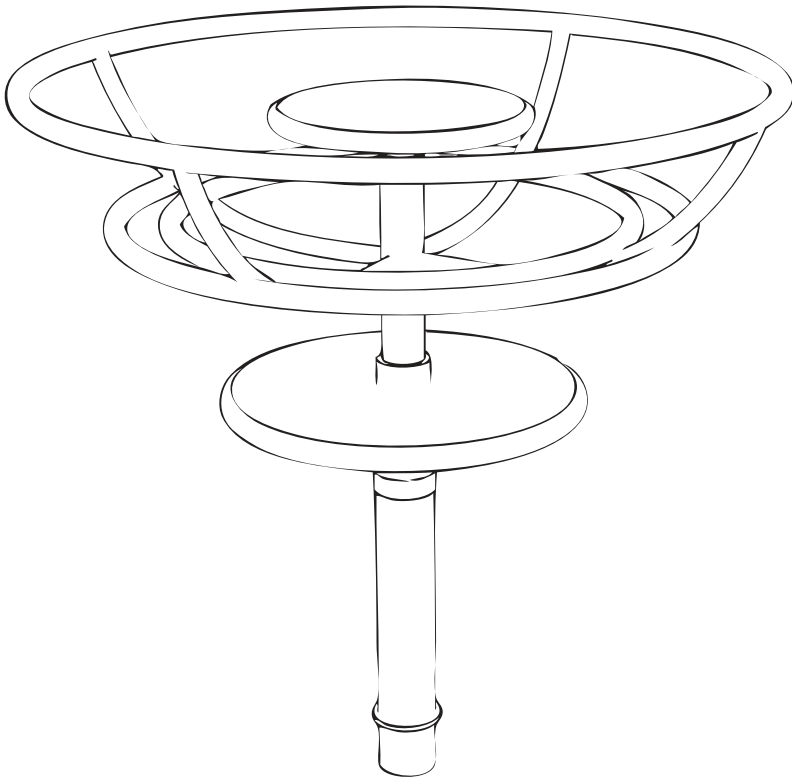

X1 (PRE-ASSEMBLED SPINNER WITH SEATING)

TOOLS required

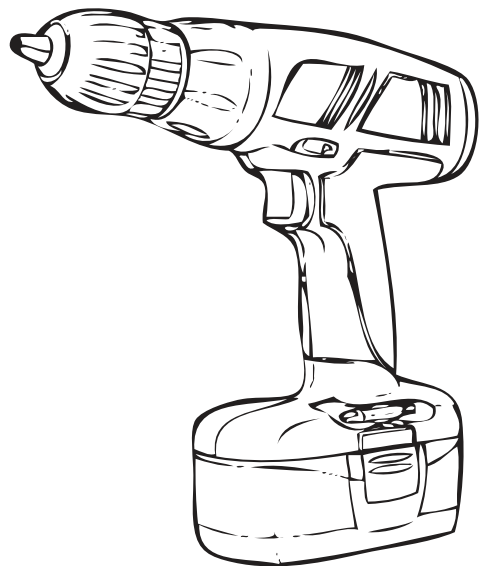

Foundation Details

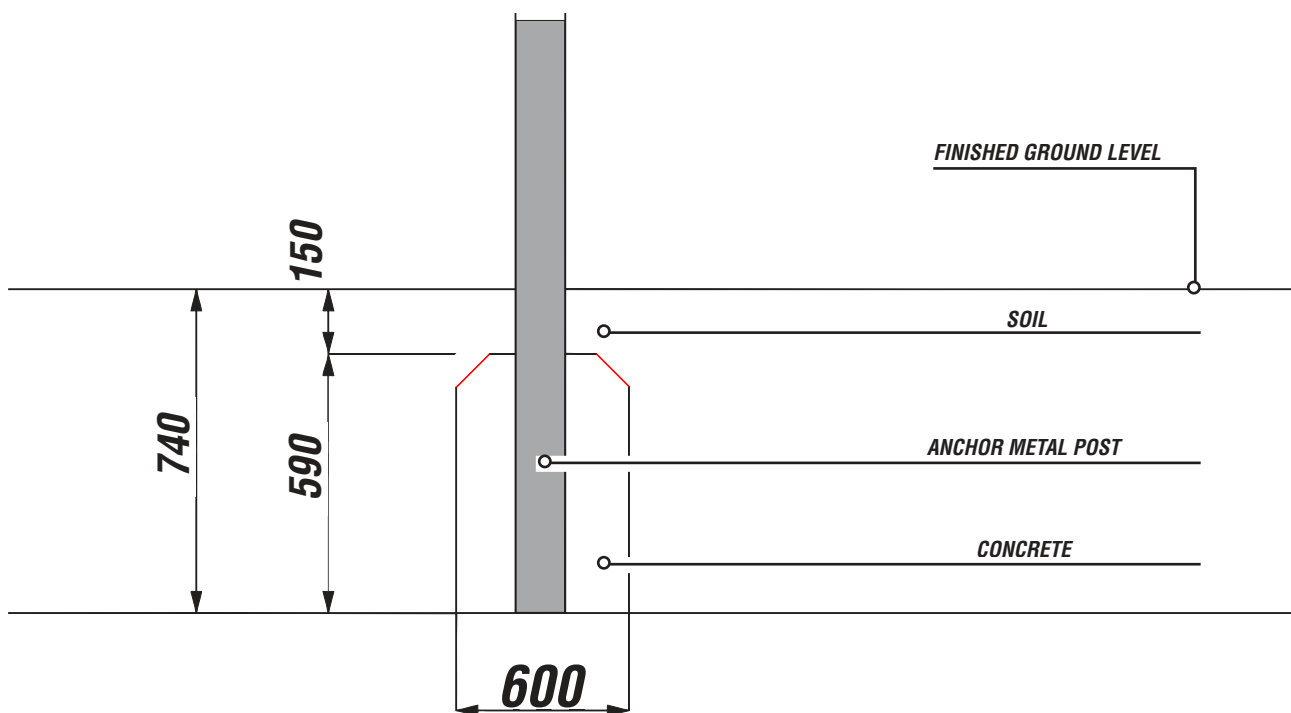
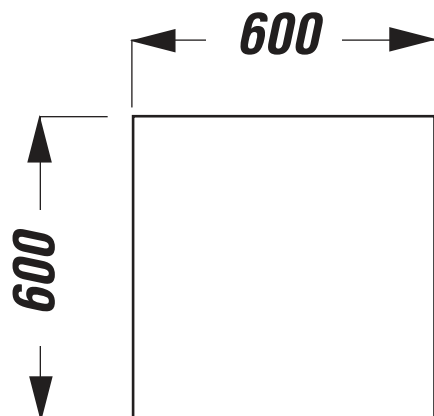

Surfacing Details

- - - = *MINIMUM SPACE*
- = *SURFACE AREA*

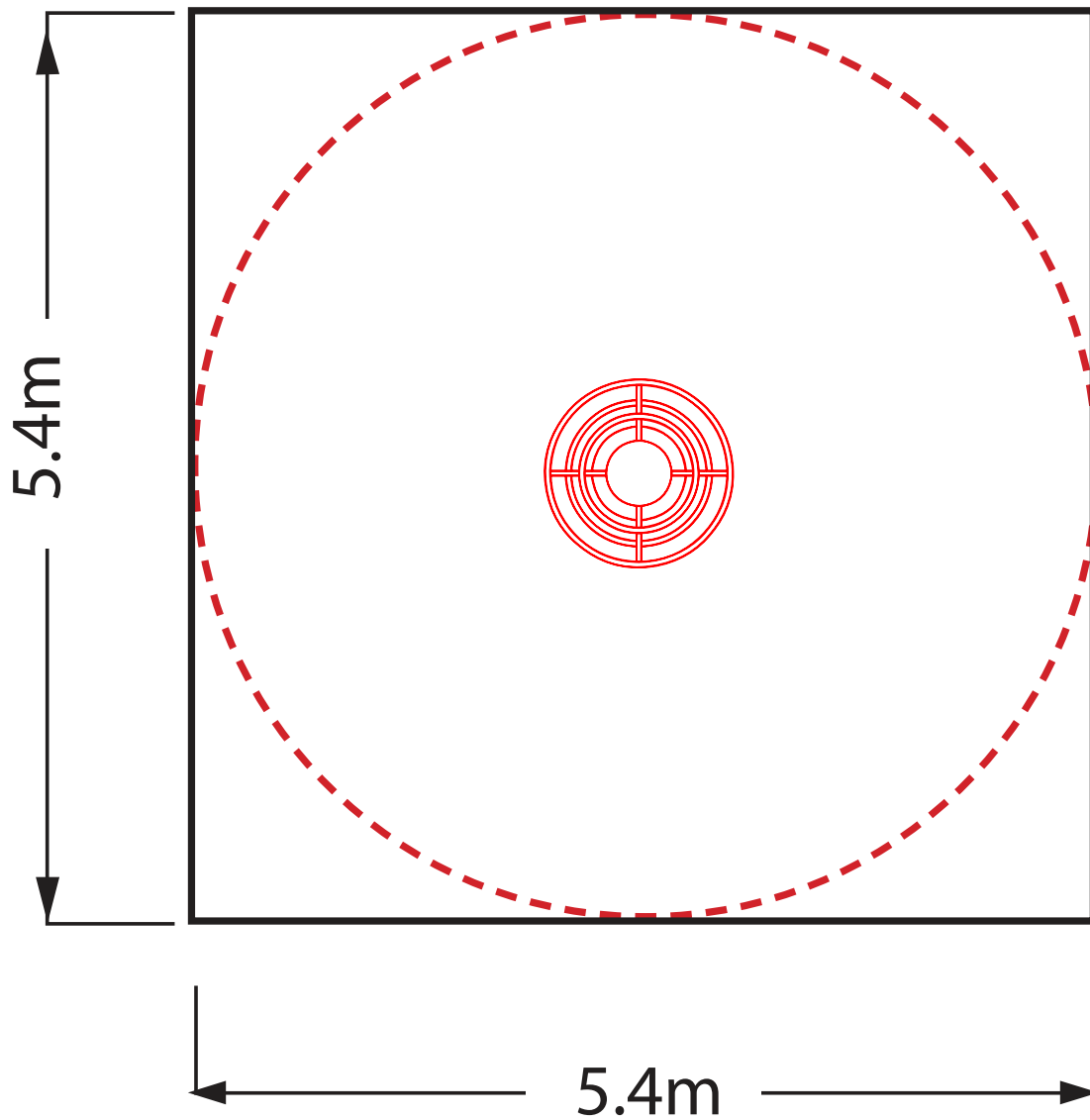

Installation Instructions

1

Install the pre-assembled Spinner as per foundation/area details.

Follow foundation details

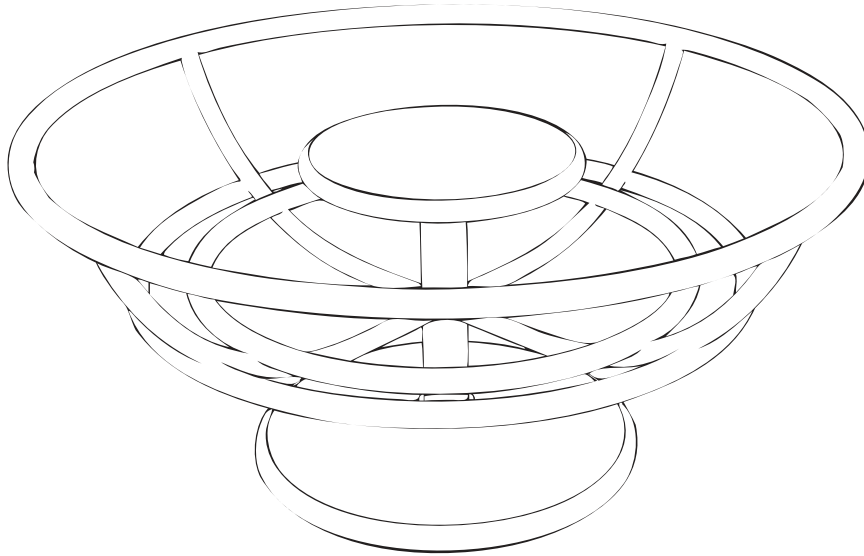

Additional Dimensions

