

# **TIMBER PLANTER & SEAT**

## ***Installation Instructions***

**creative  
play**

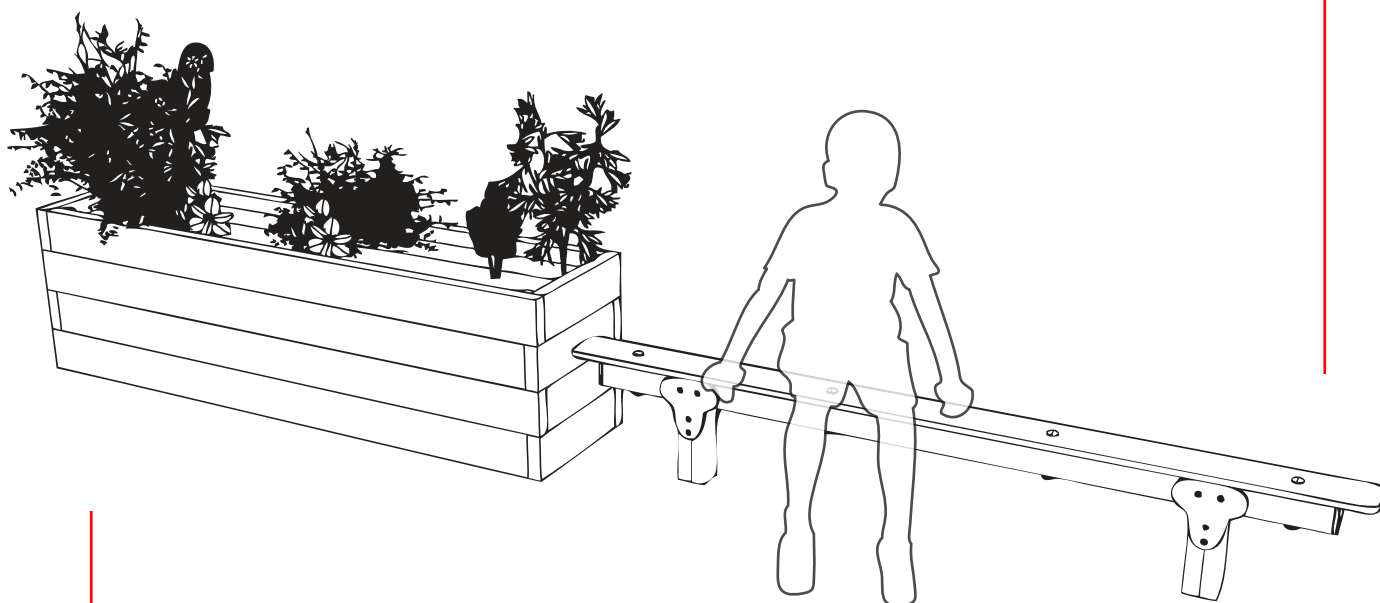

# ***PARTS required***

---

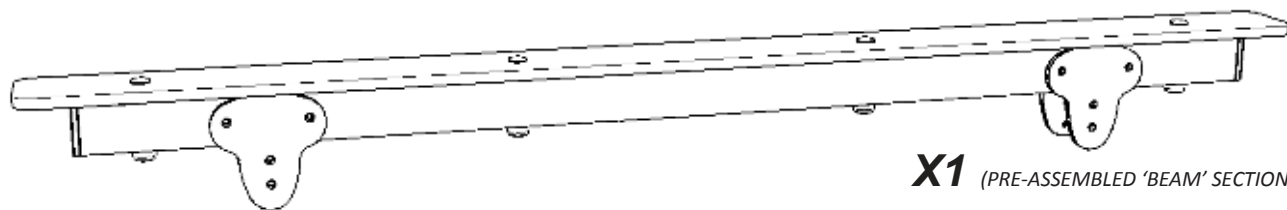

**X1** (PRE-ASSEMBLED 'BEAM' SECTION)

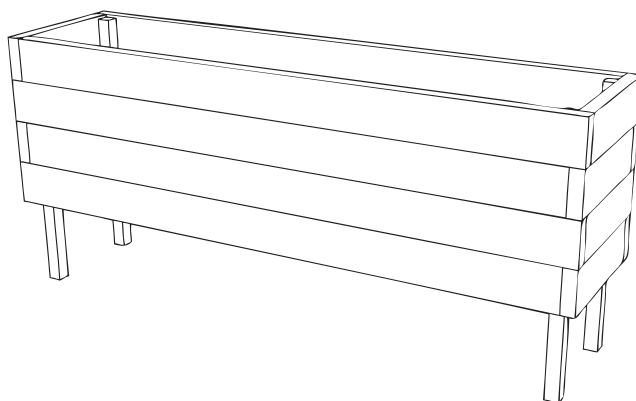

**TIMBER PLANTER 2m X 0.5m**



**X8** (FM80 'BRASS SCREW')

**BB2** QTY x 2  
(90mm x 90mm)

# ***TOOLS required***

---

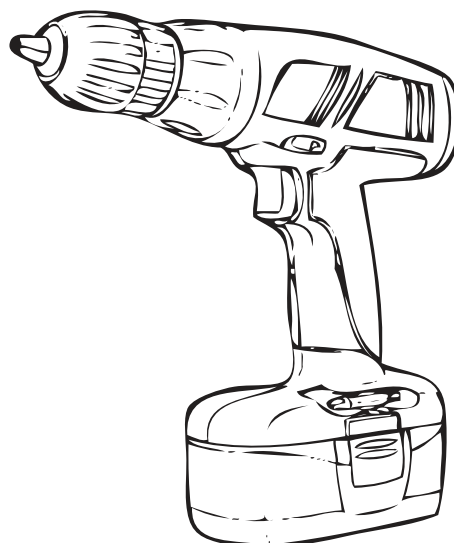

# Foundation Details

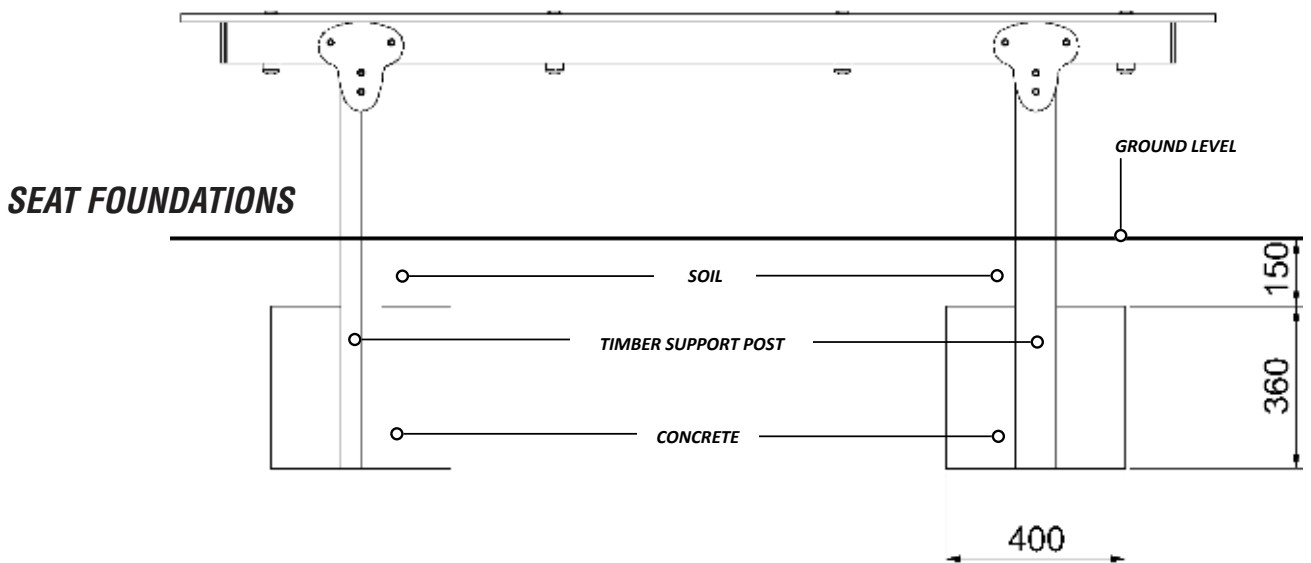
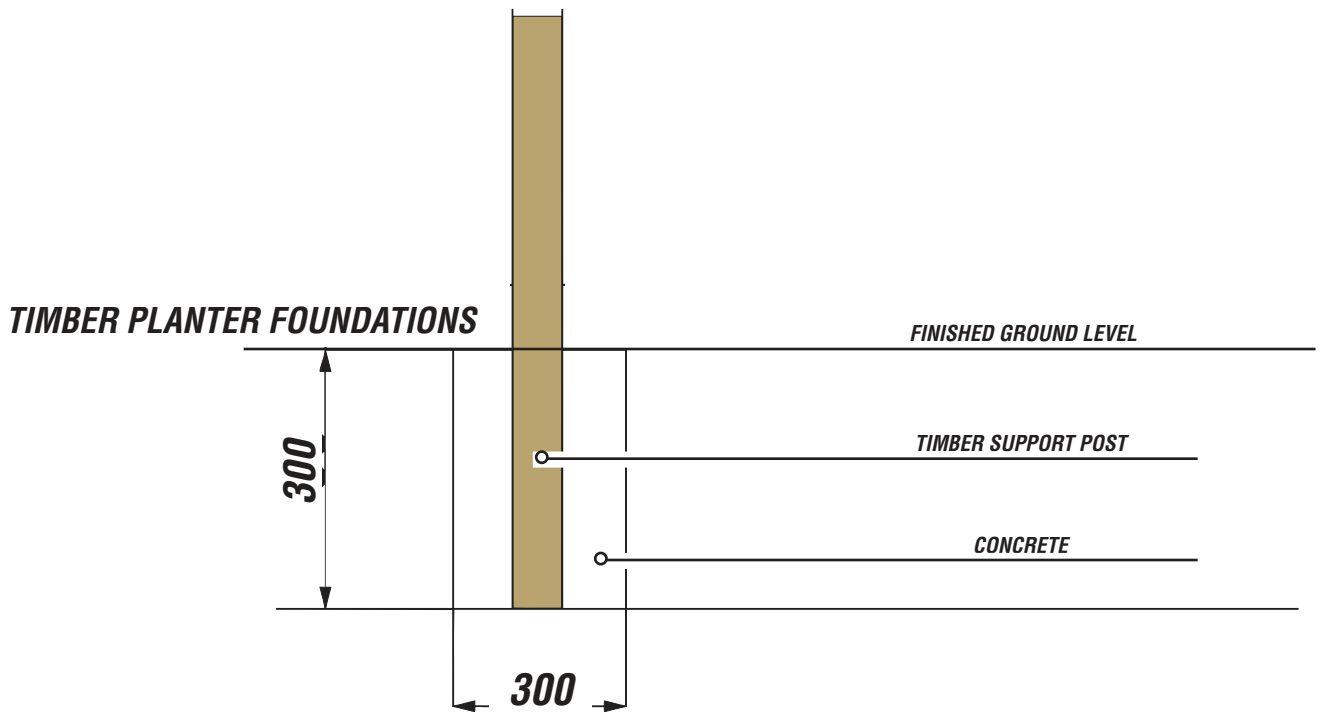
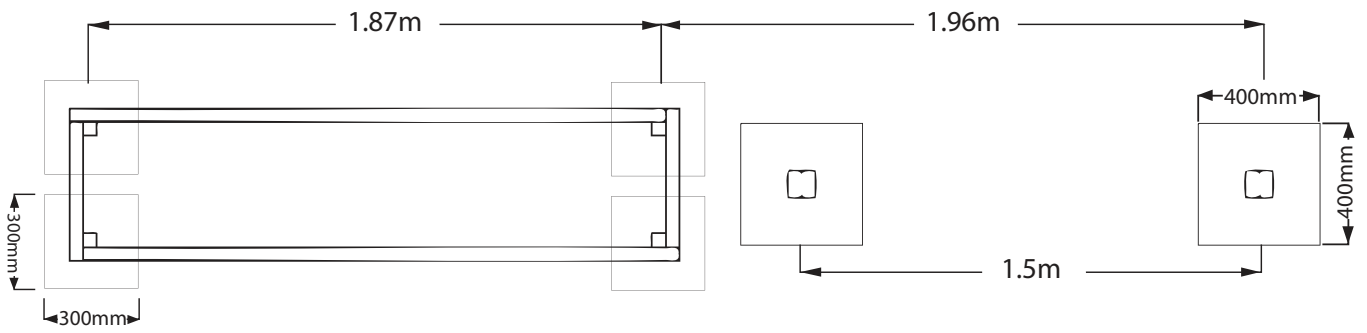

# Installation Instructions

---

**1**

## Attach the preassembled BEAM to the Timbers (BB2)

Using FM80 BRASS CREWS—ATTACH BEFORE LAYING CONCRETE FOUNDATIONS

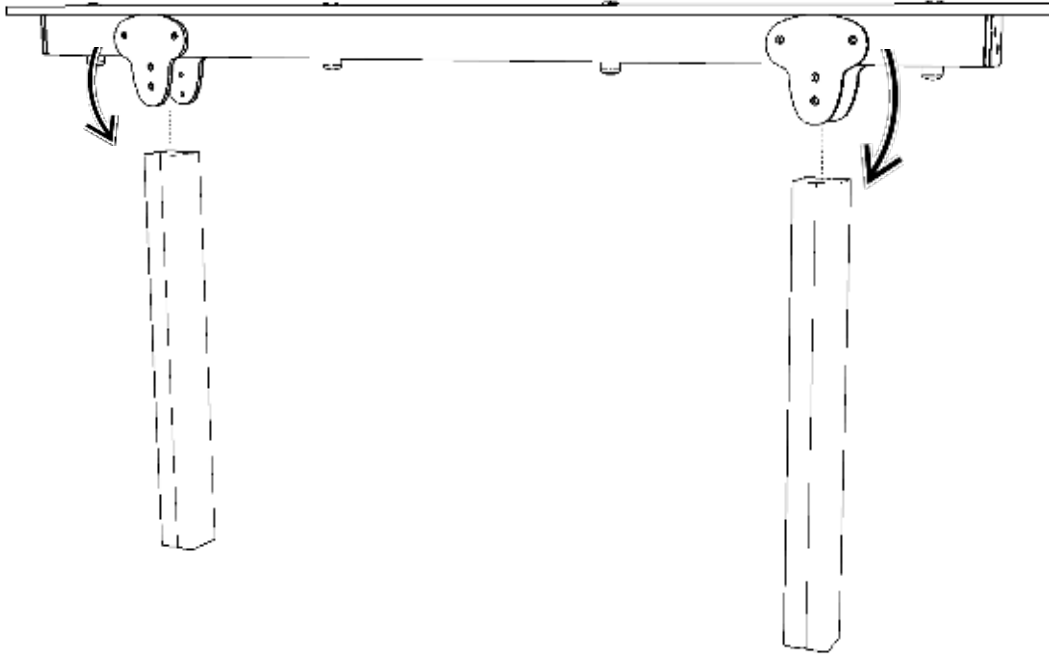

**2**

## LAY CONCRETE FOUNDATIONS

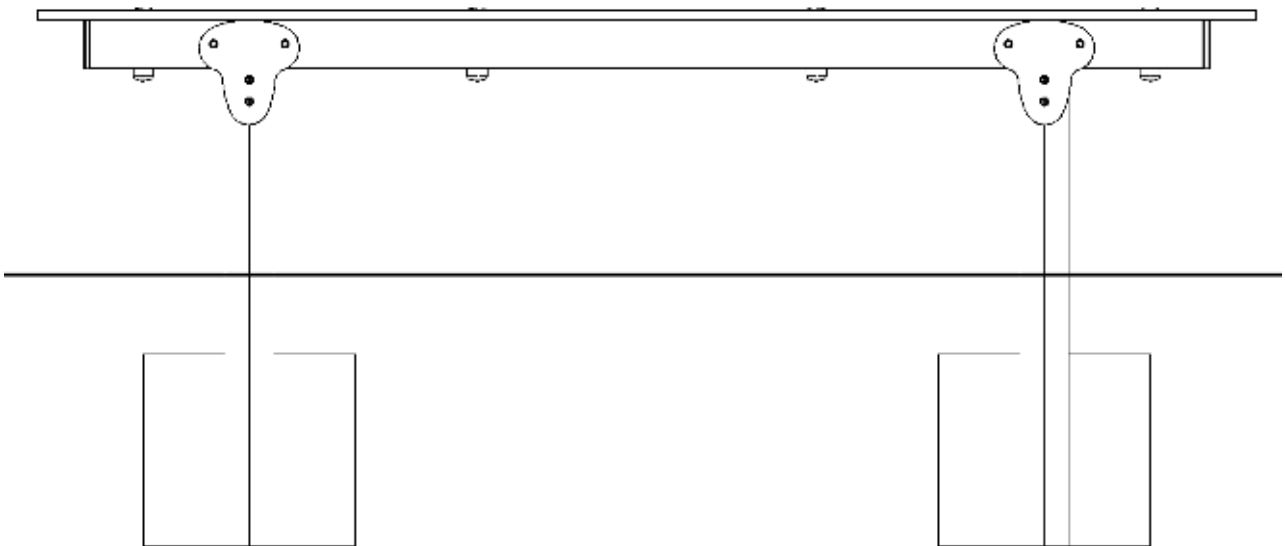

# Installation Instructions

---

**3**

## SET TIMBER PLANTER INTO FOUNDATIONS

AS SHOWN ON FOUNDATION DETAILS PAGE

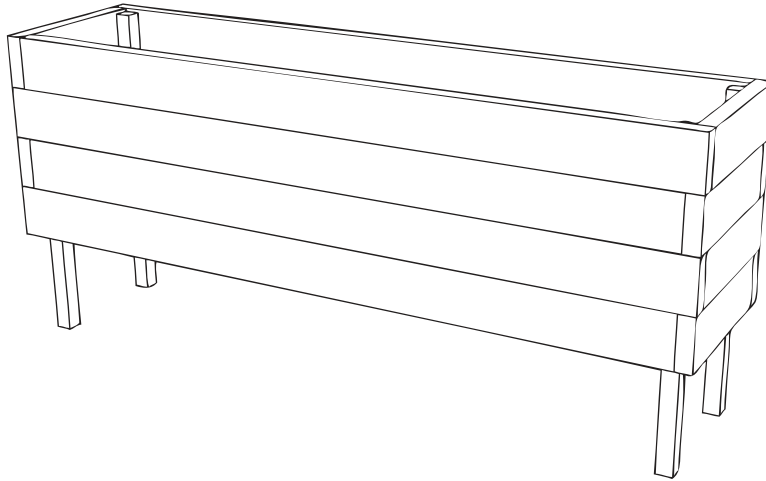

## Additional Dimensions

---

