

# MOTOR PLAY PANEL

## Installation Instructions

creative  
play

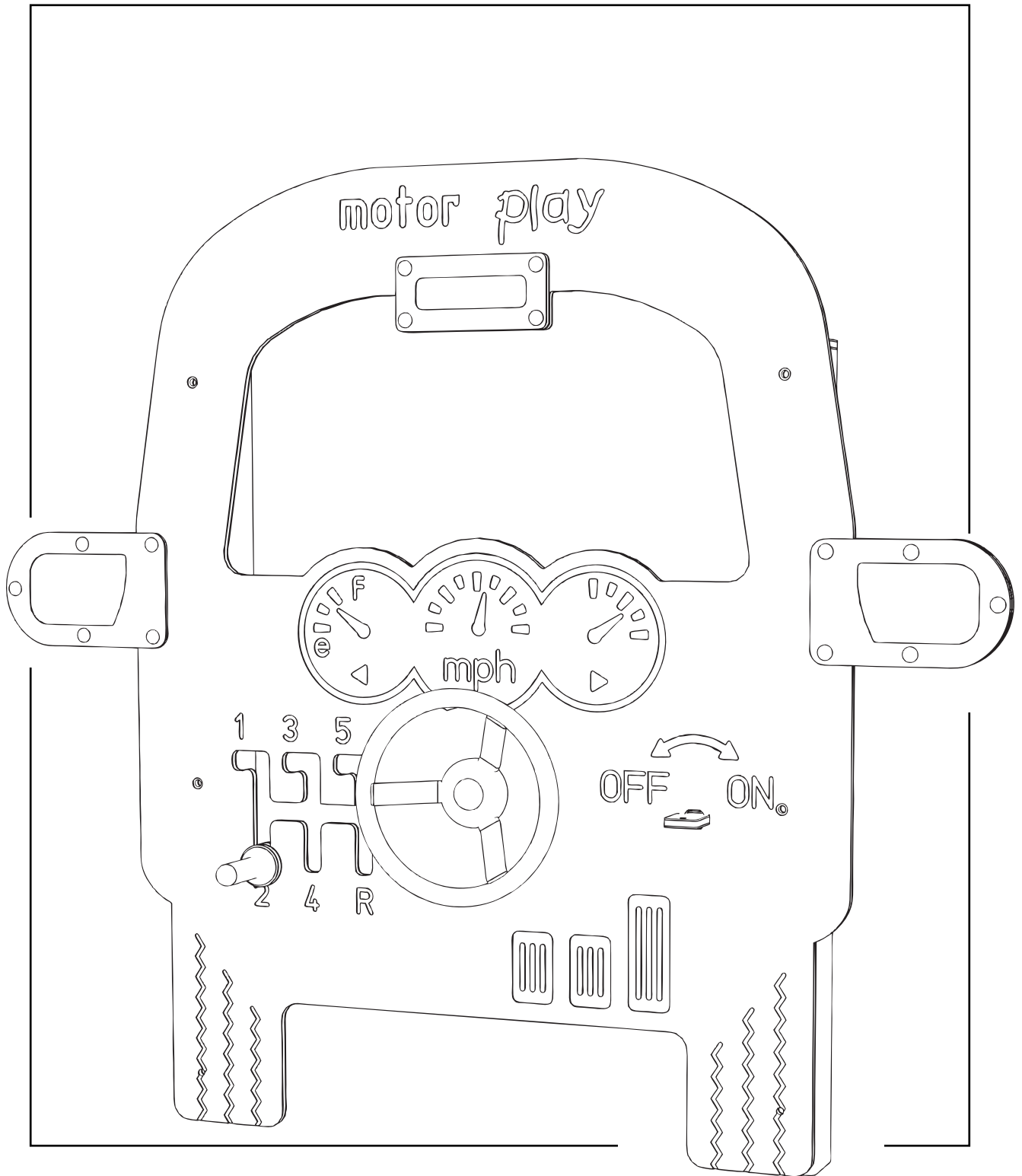

# PARTS required

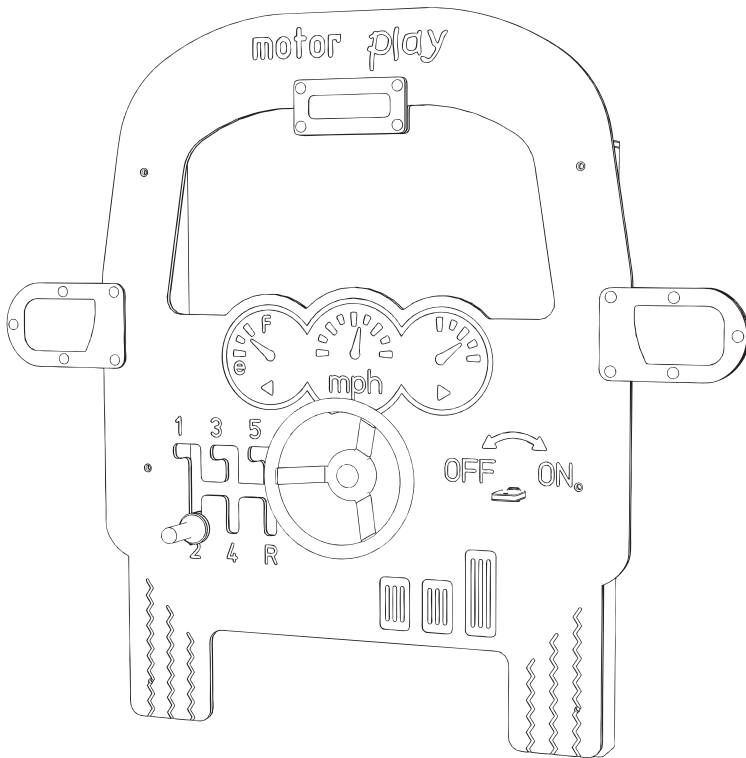

**x1** PRE-ASSEMBLED MOTOR PLAY PANEL



**x6** FM80 BRASS WOOD SCREWS

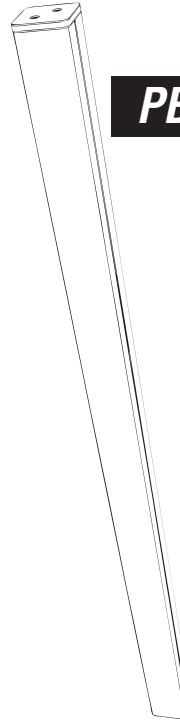

**PB112a** QTY x 2  
(90mm x 90mm)

# TOOLS required

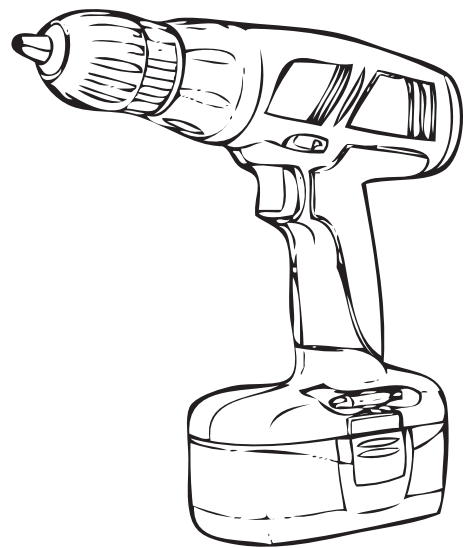
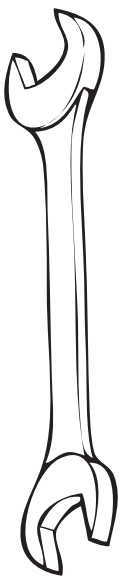

# Foundation Details

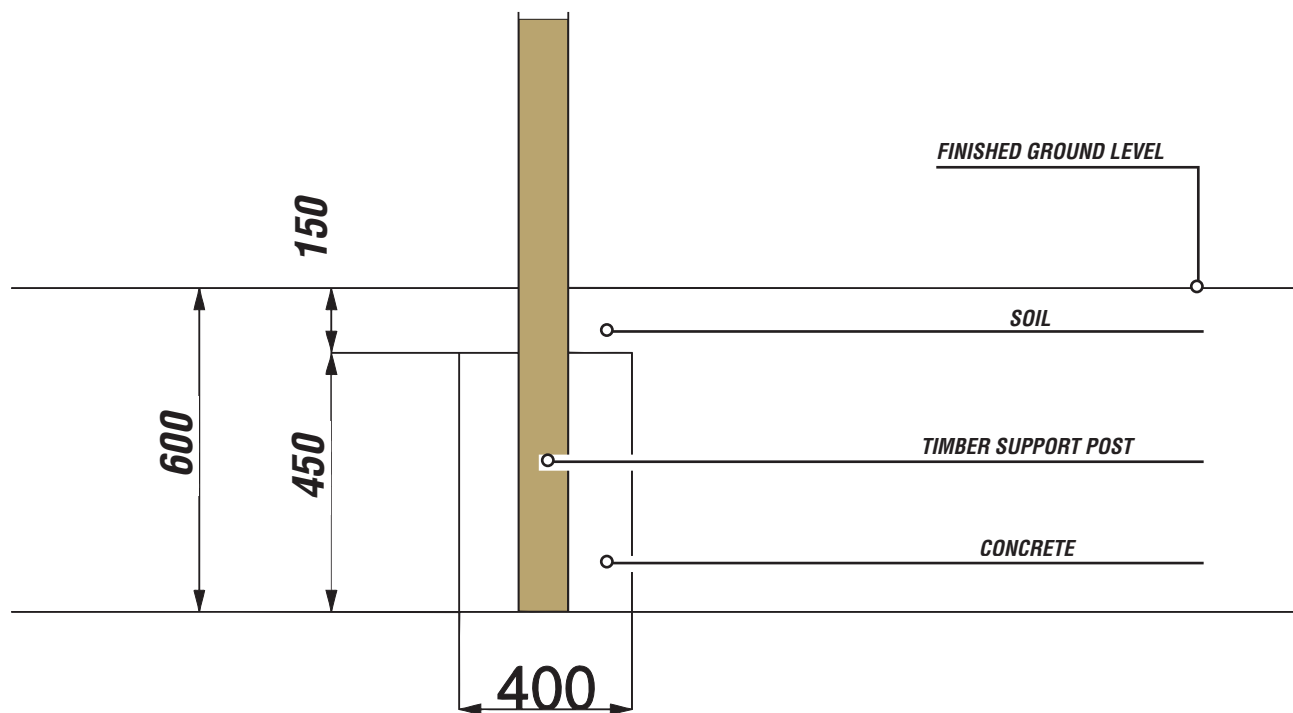
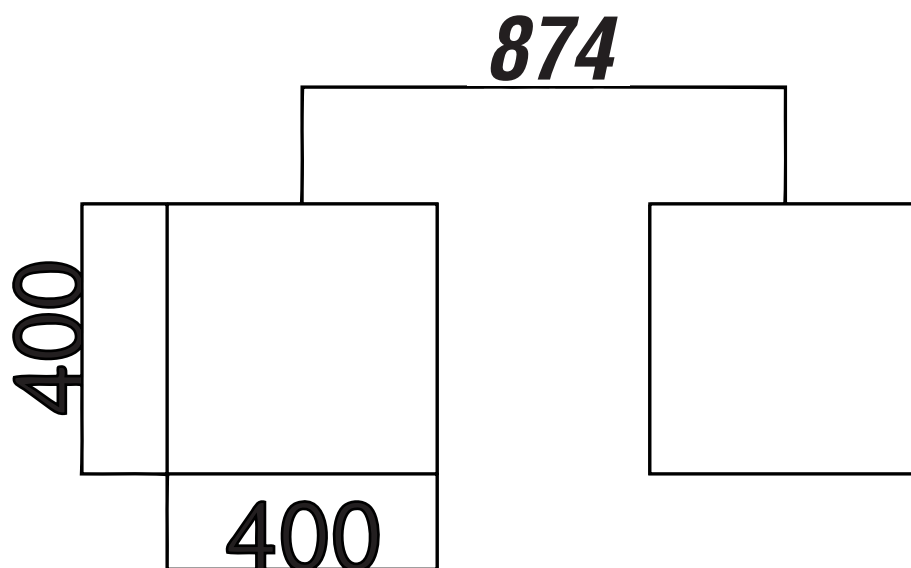

# Installation Instructions

**1**

**Attach the PRE-assembled PANEL to the TIMBERS PB112a**

Using 6x FM80 Brass Screws

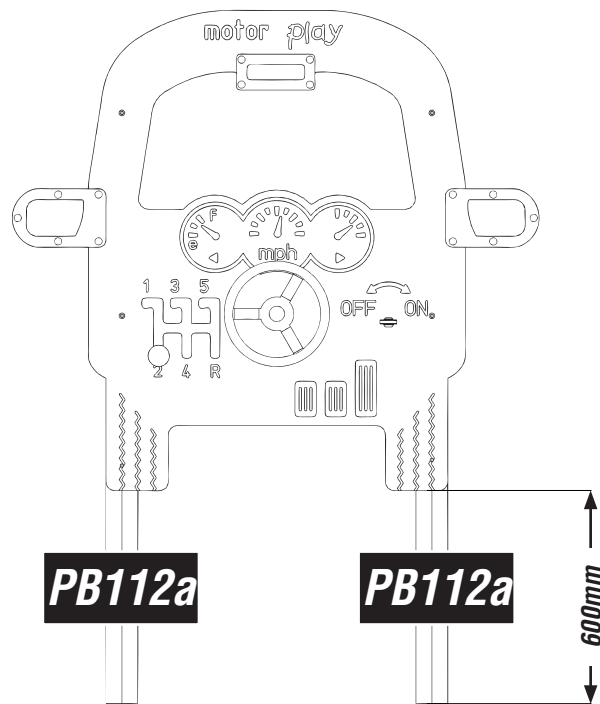

**2**

**Install the PRE-assembled PANEL with timbers**

Following fundation details

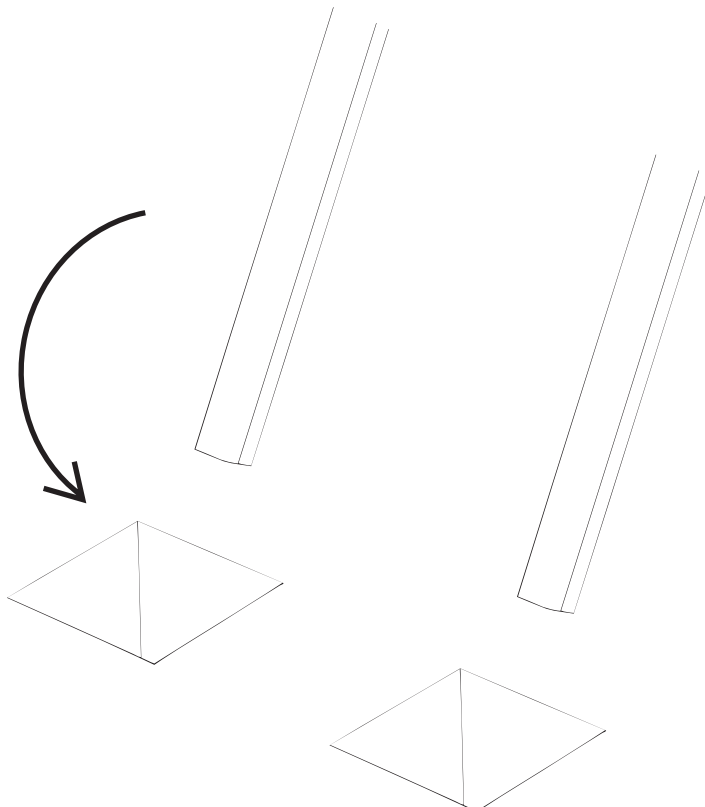

# Additional Dimensions

---

