

STORYTELLERS CHAIR

Assembly Instructions

**creative
play**

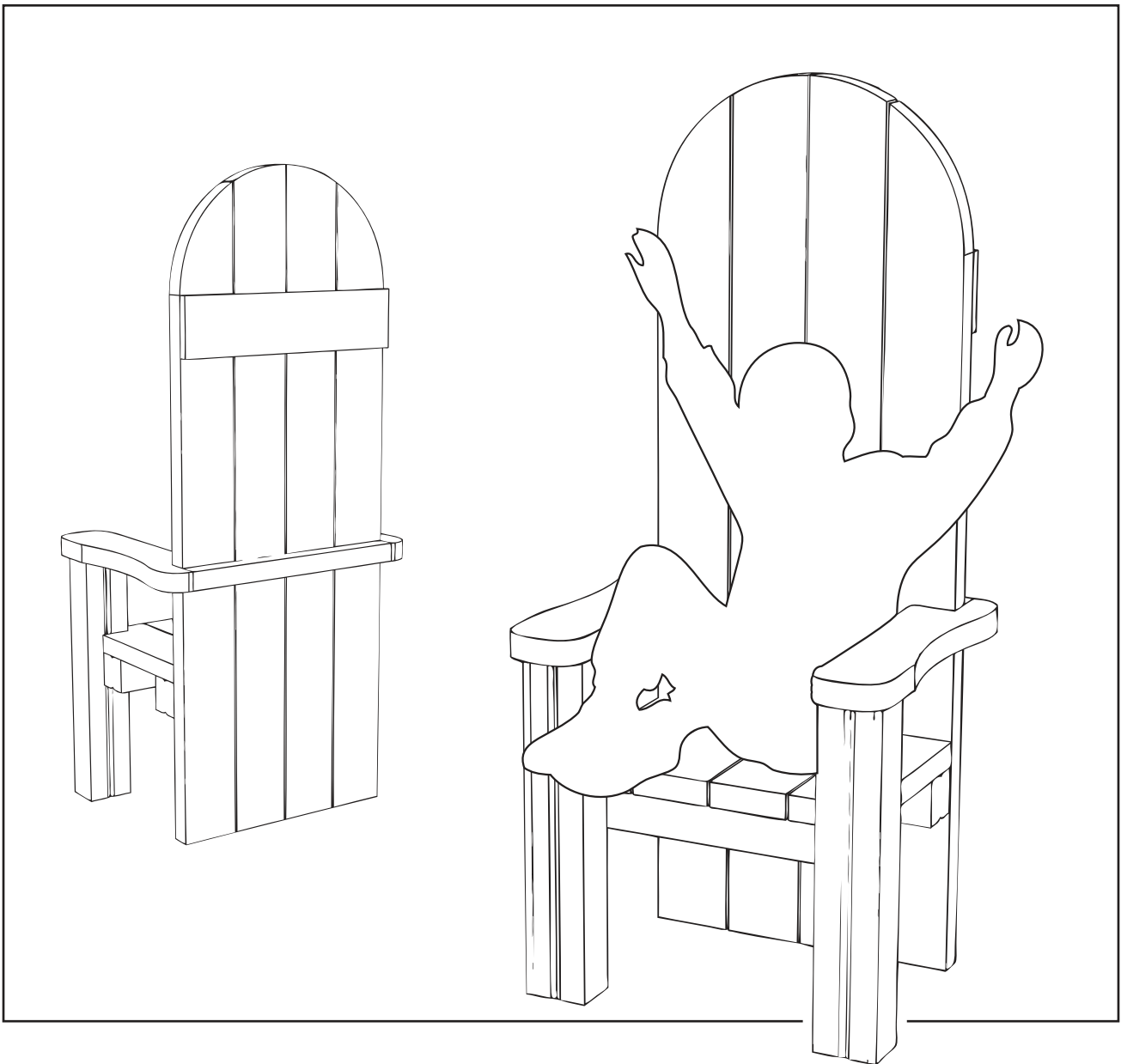

IMPORTANT - If foundation are required support legs will be have been extended 450mm

PARTS required

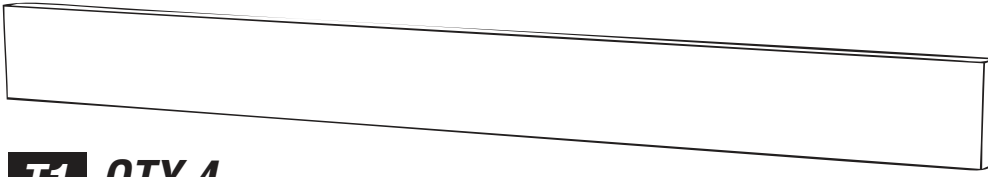

T1 QTY 4 (147mm x 47mm) - T1 TIMBERS WILL BE CUT/SHAPED

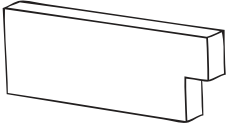

T2a QTY 2 (147mm x 47mm)

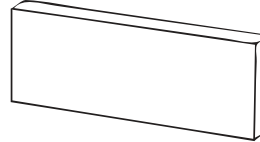

T2b QTY 2 (147mm x 47mm)



T3 QTY 2 (147mm x 47mm)



T4 QTY 2 (120mm x 90mm)

**IMPORTANT - if foundations required additional 450mm included (T4 timber)*

If freestanding use angle cleats and expansion bolts/excalibur bolts to secure seats onto tarmac

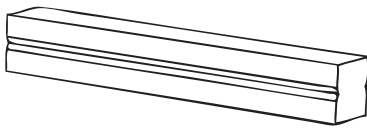

T5 QTY 2 (90mm x 90mm)

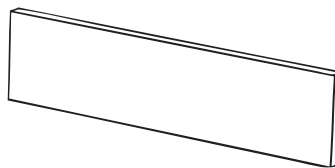

T6 QTY 1 (147mm x 22mm)

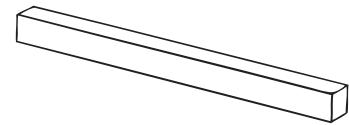

T7 QTY 1 (47mm x 47mm)



x6 (80mm brass screws)



x26 (120mm brass screws)

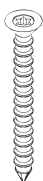

x4 (40mm brass screws)

PARTS required ...

OPTIONAL - If installed onto tarmac/concrete

NOT REQUIRED IF SUPPORT POSTS HAVE BEEN EXTENDED FOR FOUNDATIONS



x2 *(angle cleats/brackets)*



x2 *(40mm brass screws)*

x2

expansion bolts / excalibur bolts
To be used to secure seats onto tarmac

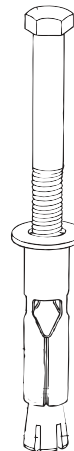

TOOLS required

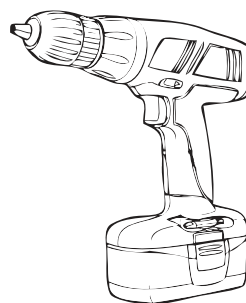
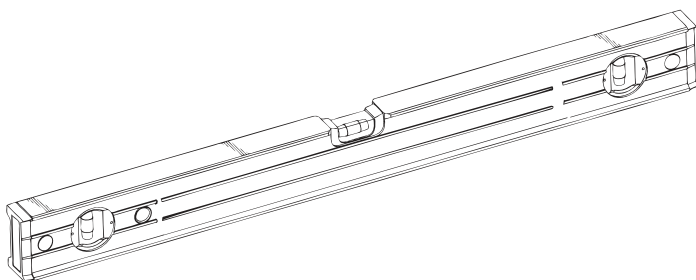

Foundation Details

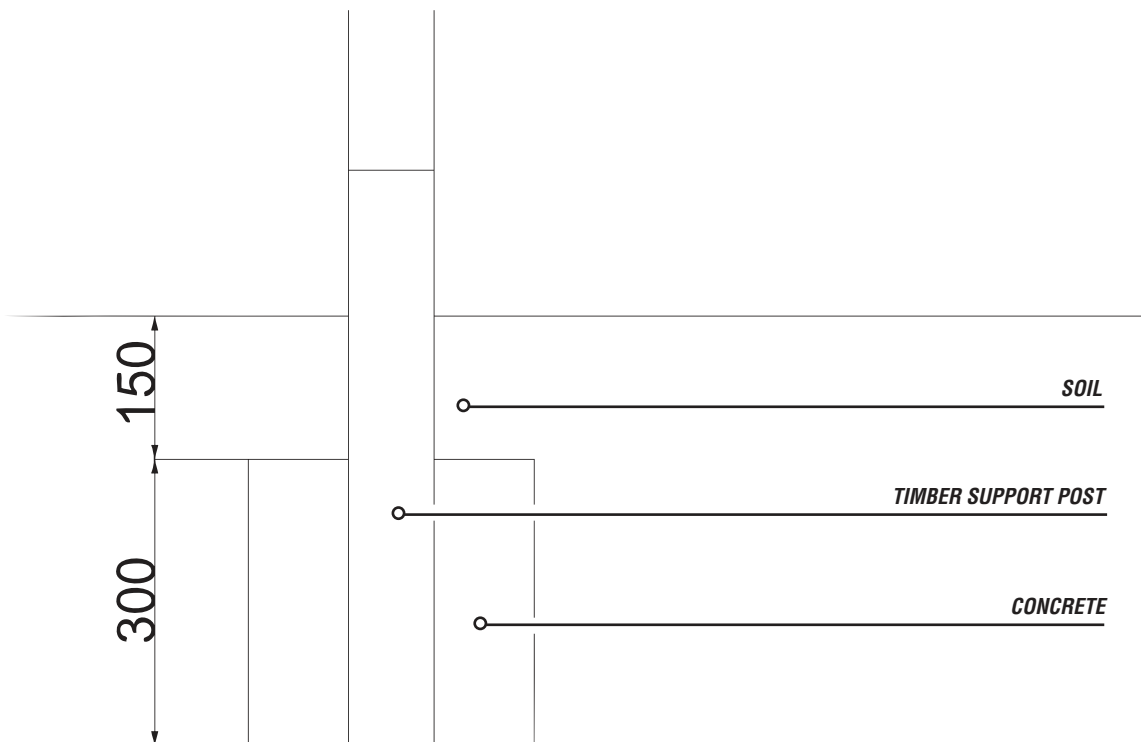
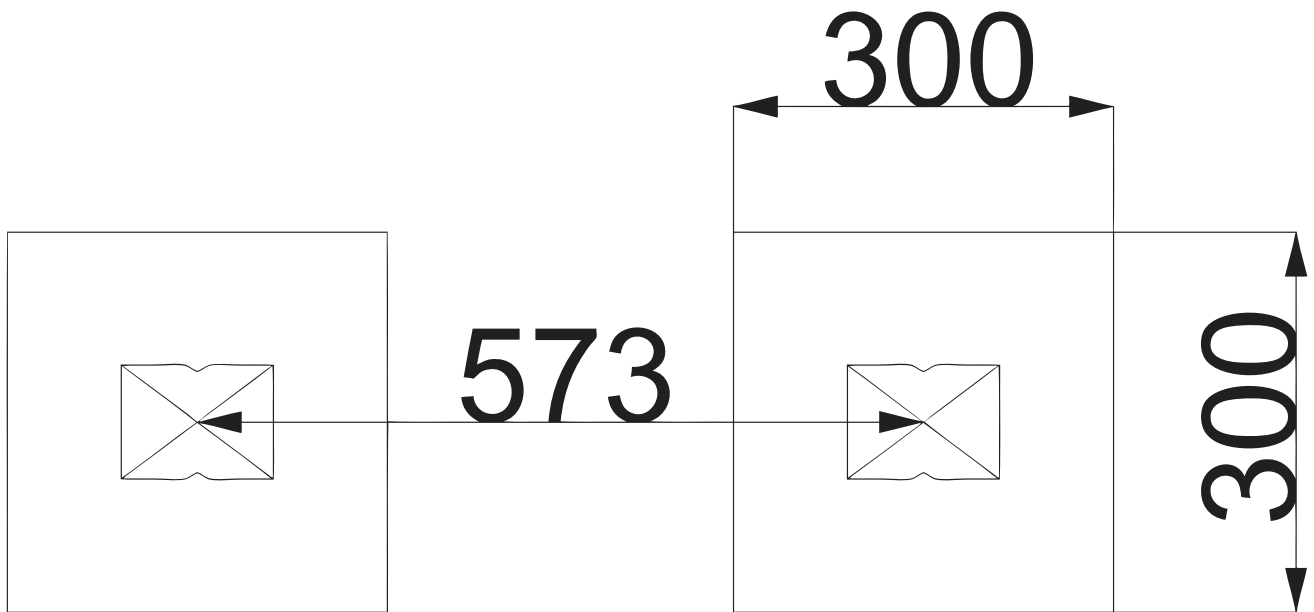

Assembly Instructions

1

If the bench IS pre-assembled **JUMP TO STEP 8**

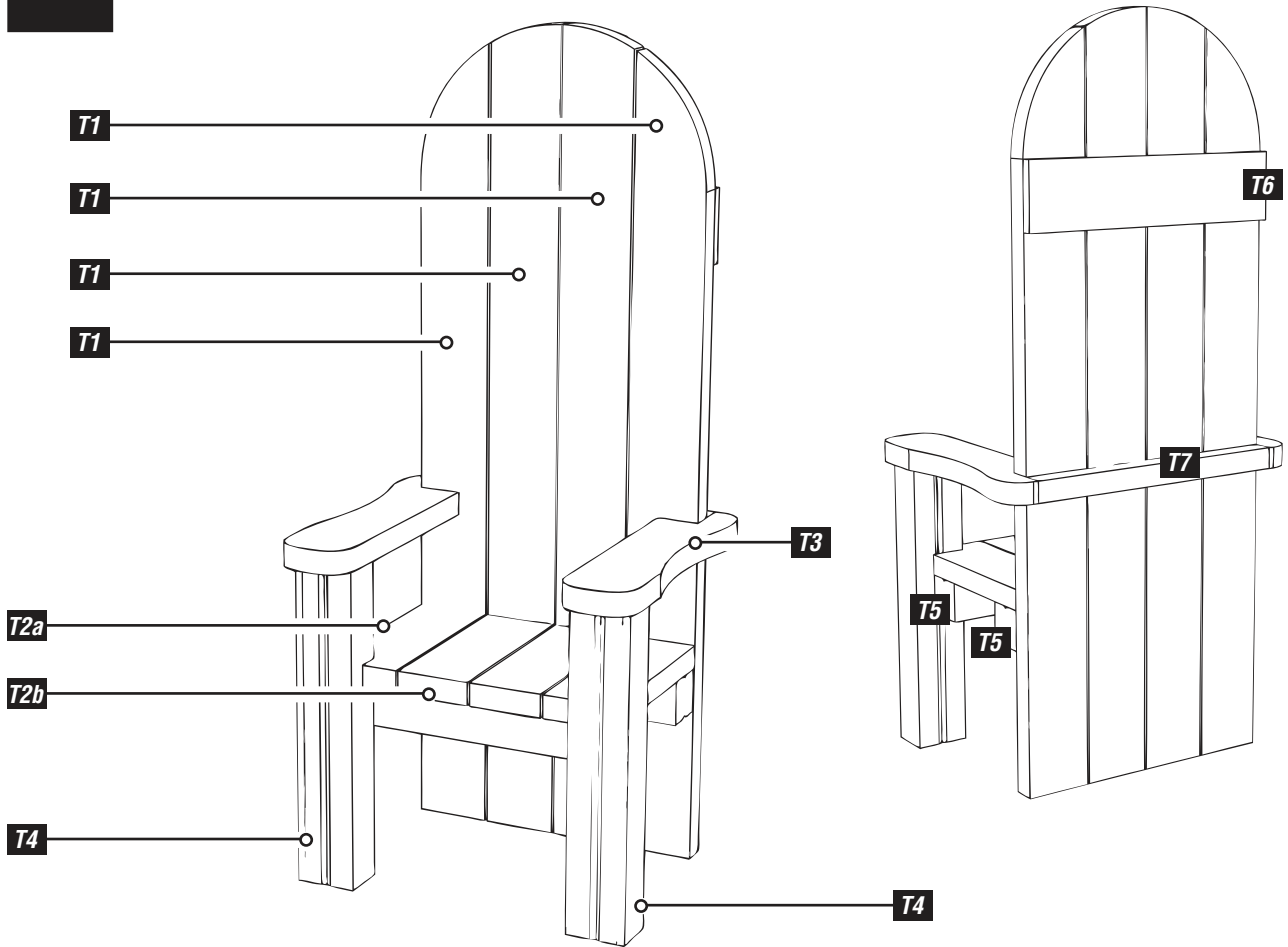

2

Attach T1 timbers to T6 timber

Using 40mm brass screws

1350mm (start of the curve on the T1 timber)

- 5mm gap between T1 timbers

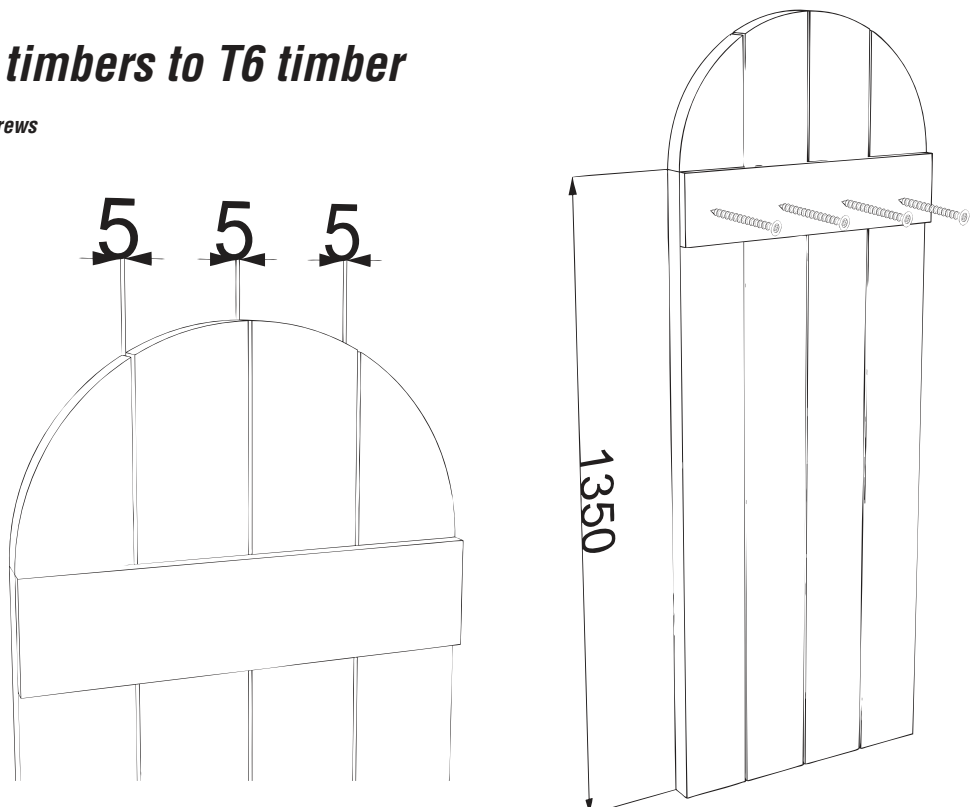

Assembly Instructions

3

Assemble the 'seat' section

Using 120mm brass screws

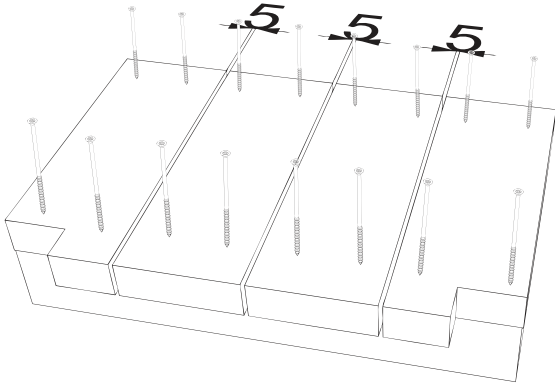

5mm gap between T2 timbers

- Use 4 screws per SLAT ensure they are uniform and screw into the centre of the T5 timbers

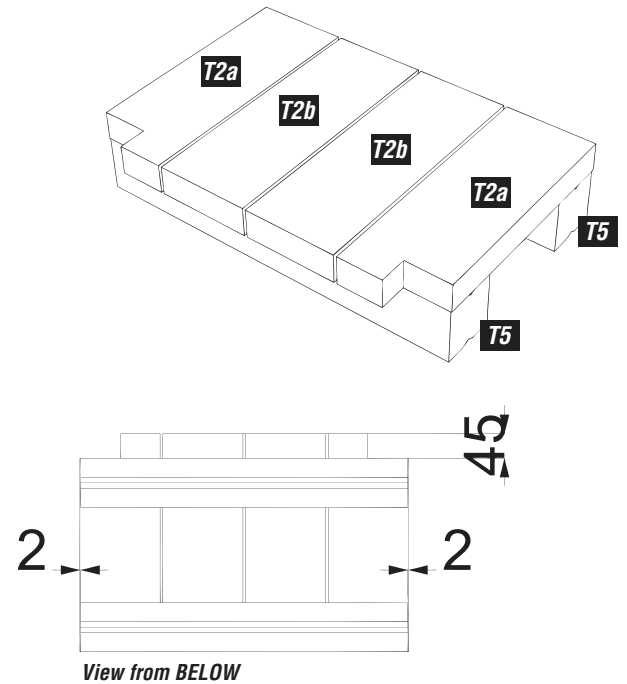

4

Attach the SEAT to the BACK

Using 120mm brass screws

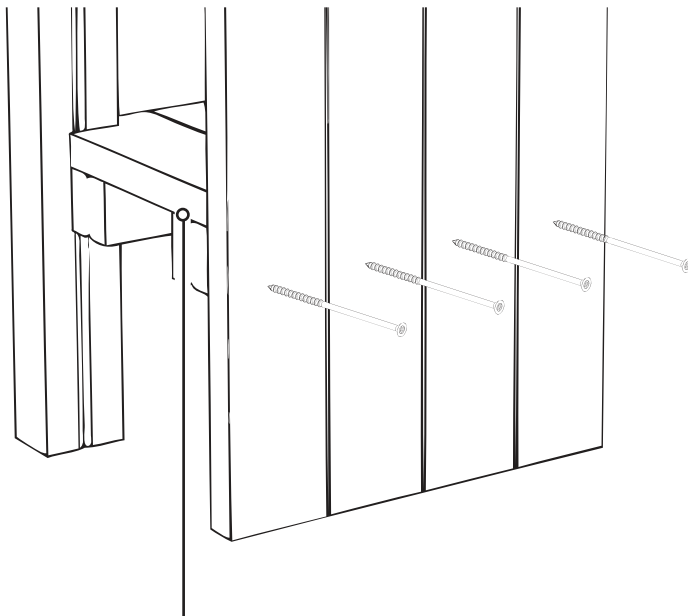

Outer face of T2 timbers & T1 timbers are flush/level with each other

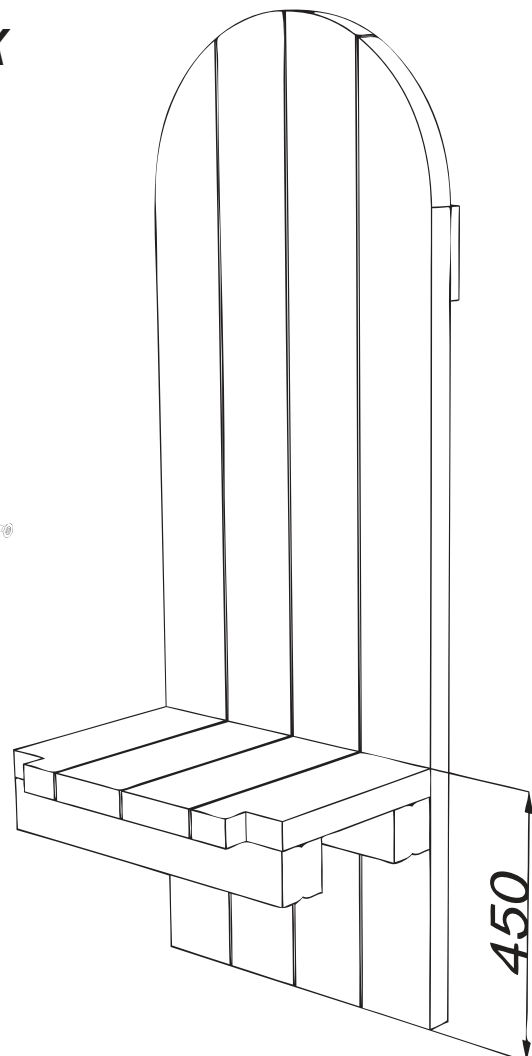

Assembly Instructions

5

Attach T4 timbers

Using 120mm brass screws

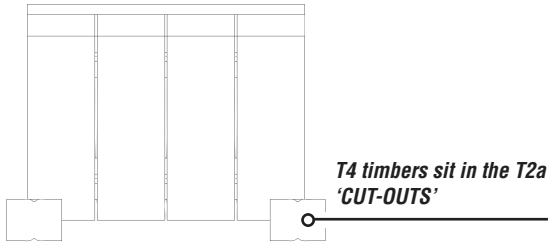

*Bottom of T4 timbers are level with the T1 timbers

If extended for concrete foundations allow additional 450mm

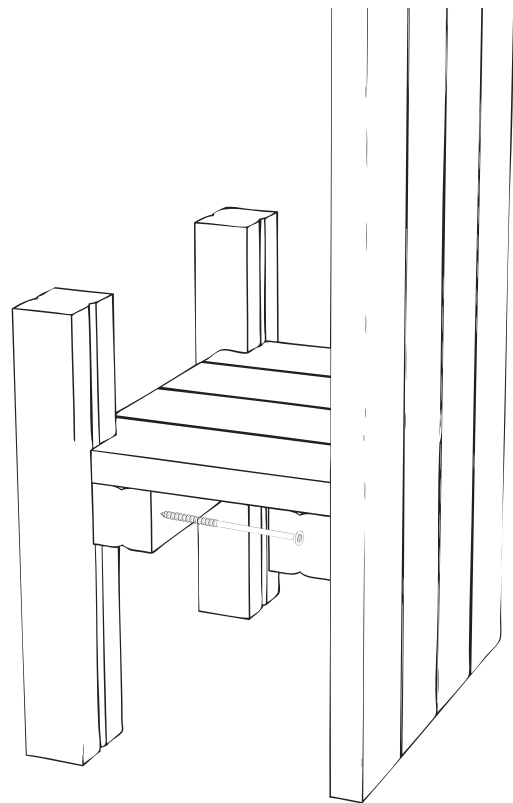
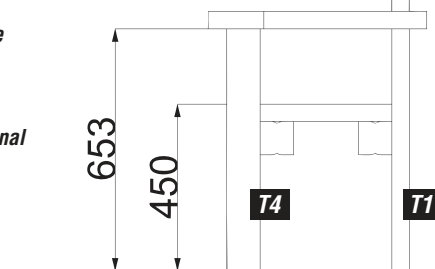

6

Screw T3 timbers to the T4 timbers (arm rests)

Using 80mm & 120mm brass screws

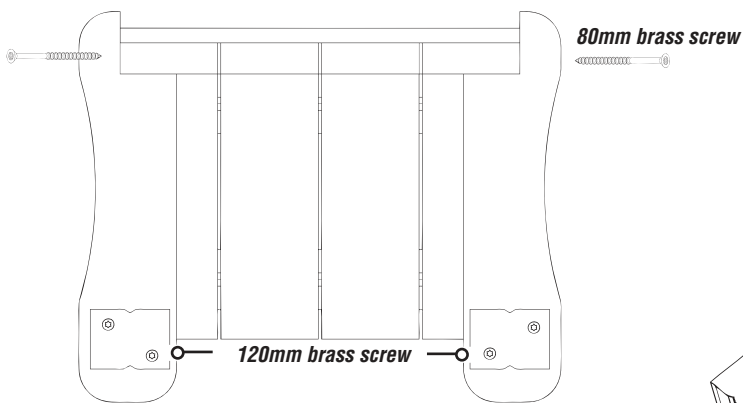

Screw as shown above

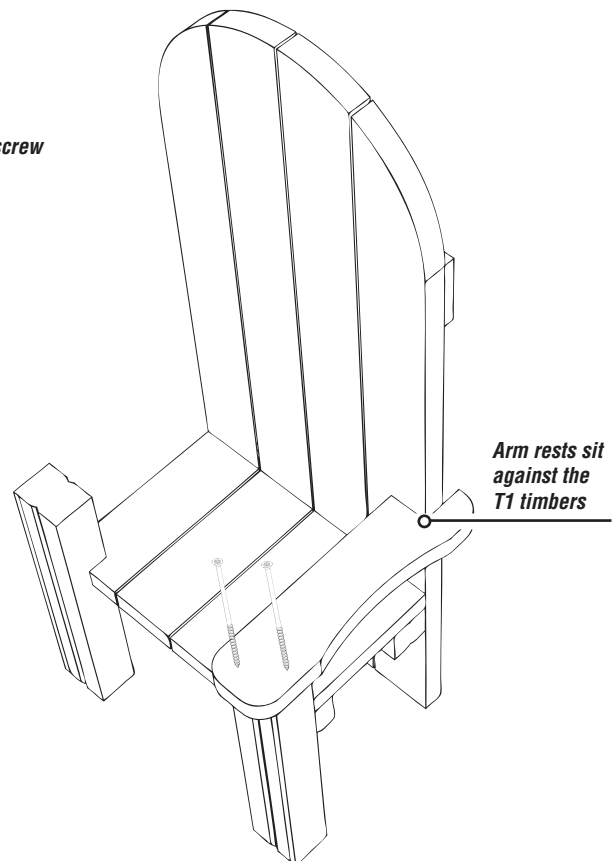

Assembly Instructions

7

Screw T7 timber to the T1 timbers

Using 80mm brass screws

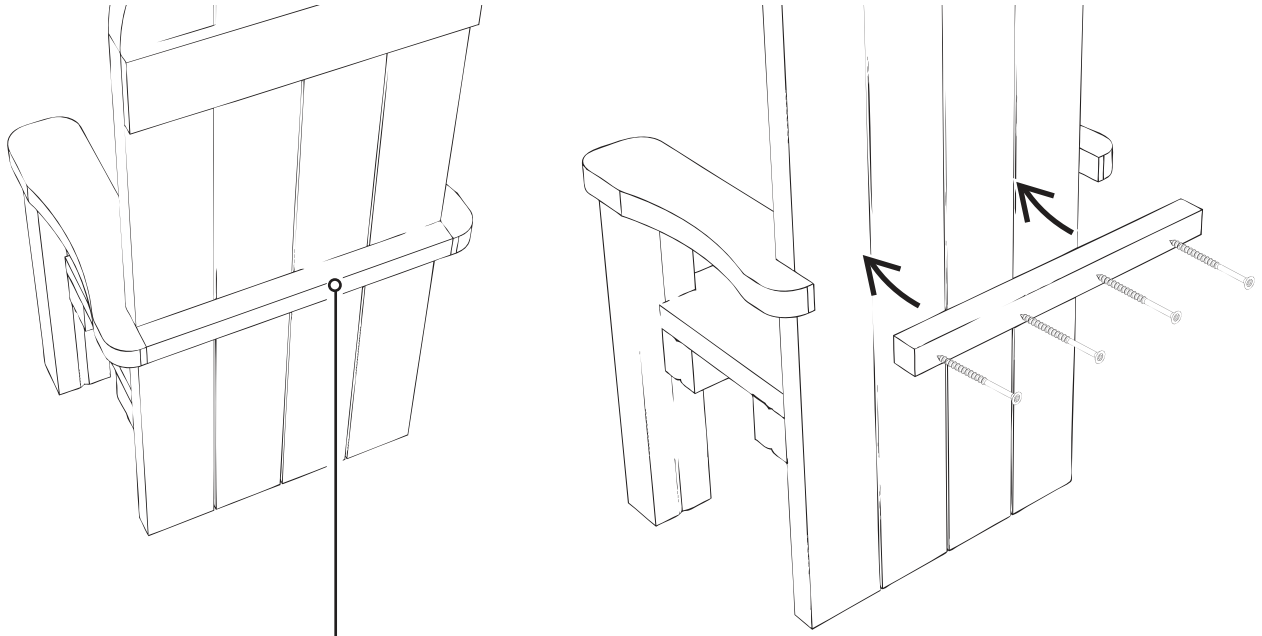

Sits between the ARM RESTS

8

Install the ASSEMBLED BENCH

Using ANGLE CLEATS with 40mm brass screws and EXPANSION BOLTS or CONCRETE INTO GROUND as per foundation drawings

Follow the FOUNDATION DETAILS on Page 4

OR

Position angle cleats on the INSIDE of each SUPPORT

- Use 40mm brass screws to attach angle cleat to the support legs
- Use expansion bolts or EXCALIBUR bolts to secure the bolts to the concrete / tarmac

T4 timbers will have been extended if concrete foundations required

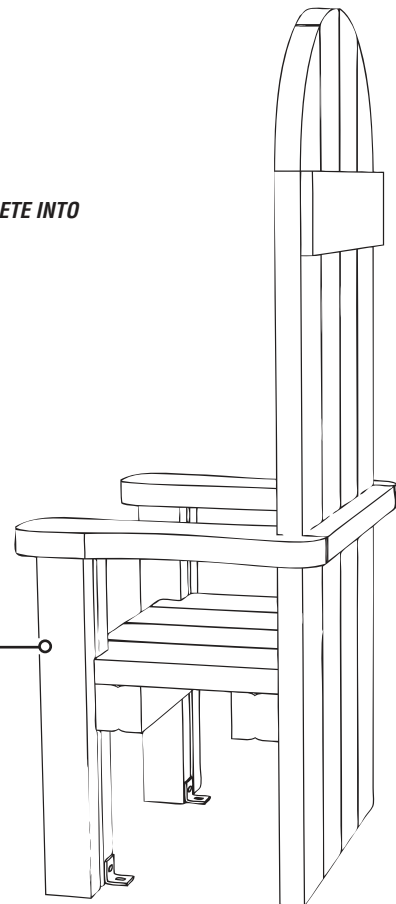

CUT-OUT OPTION AVAILABLE

CUT-OUT OPTION

*The CUT-OUT option is identical to the 'standard' version
The T1 timbers have had SIMPLE circles and 1 x STAR cut out*

