

TWISTED NET

Assembly Instructions

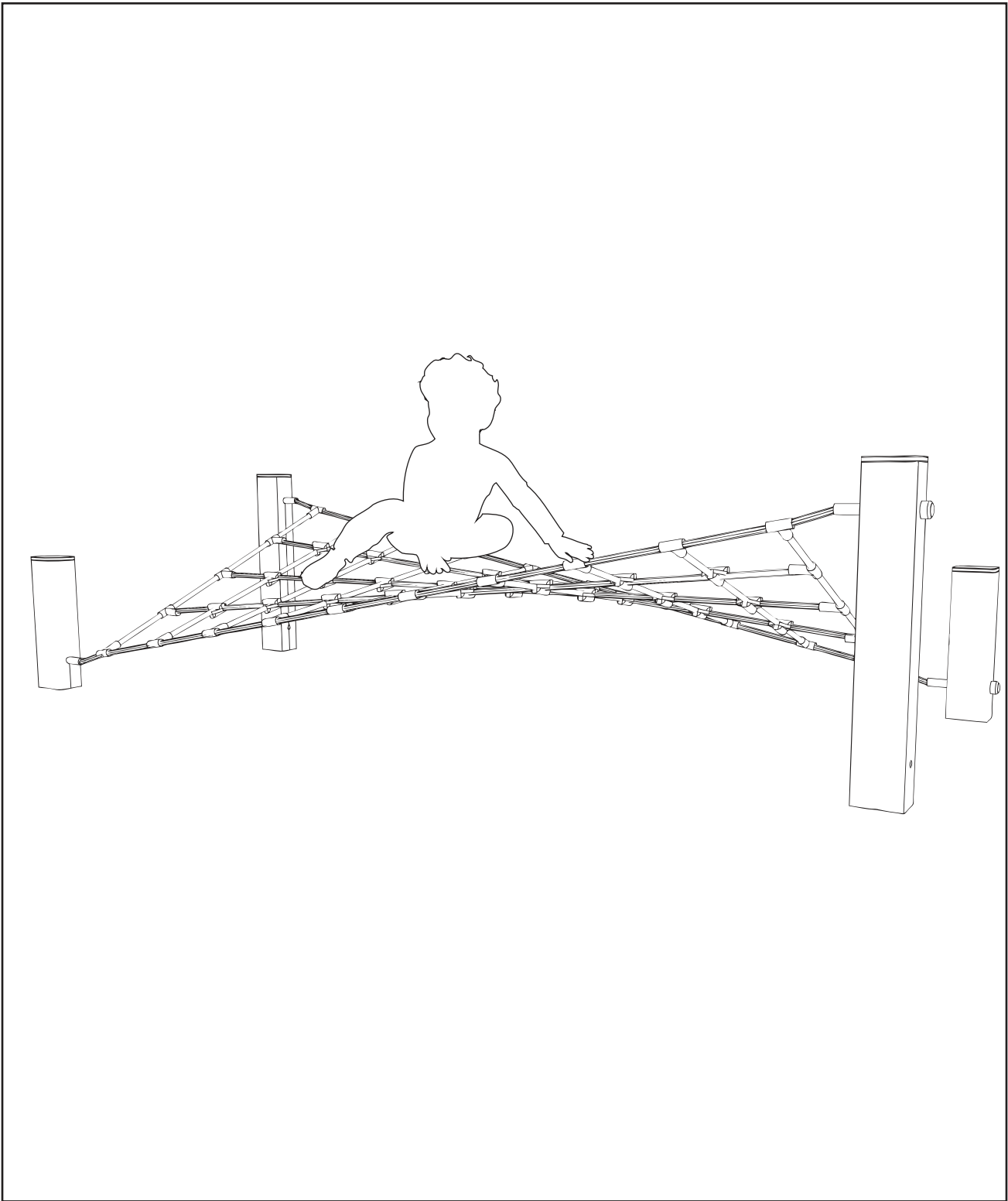

PARTS required

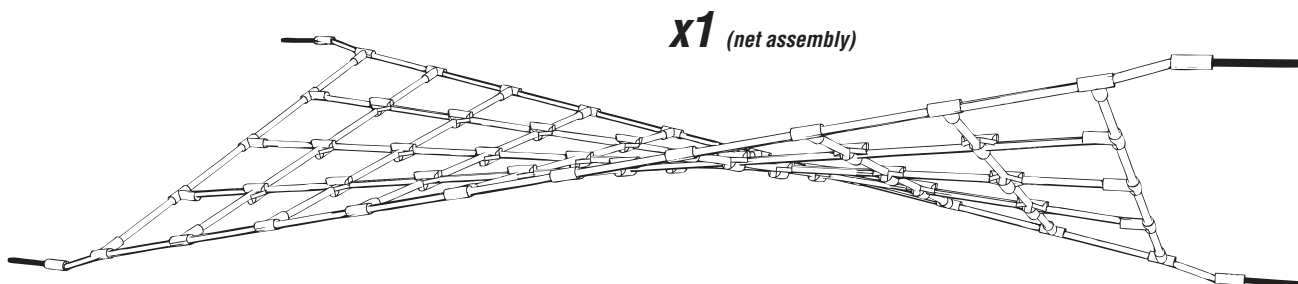

TOOLS required

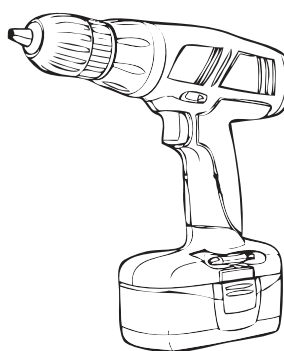

Foundation Details

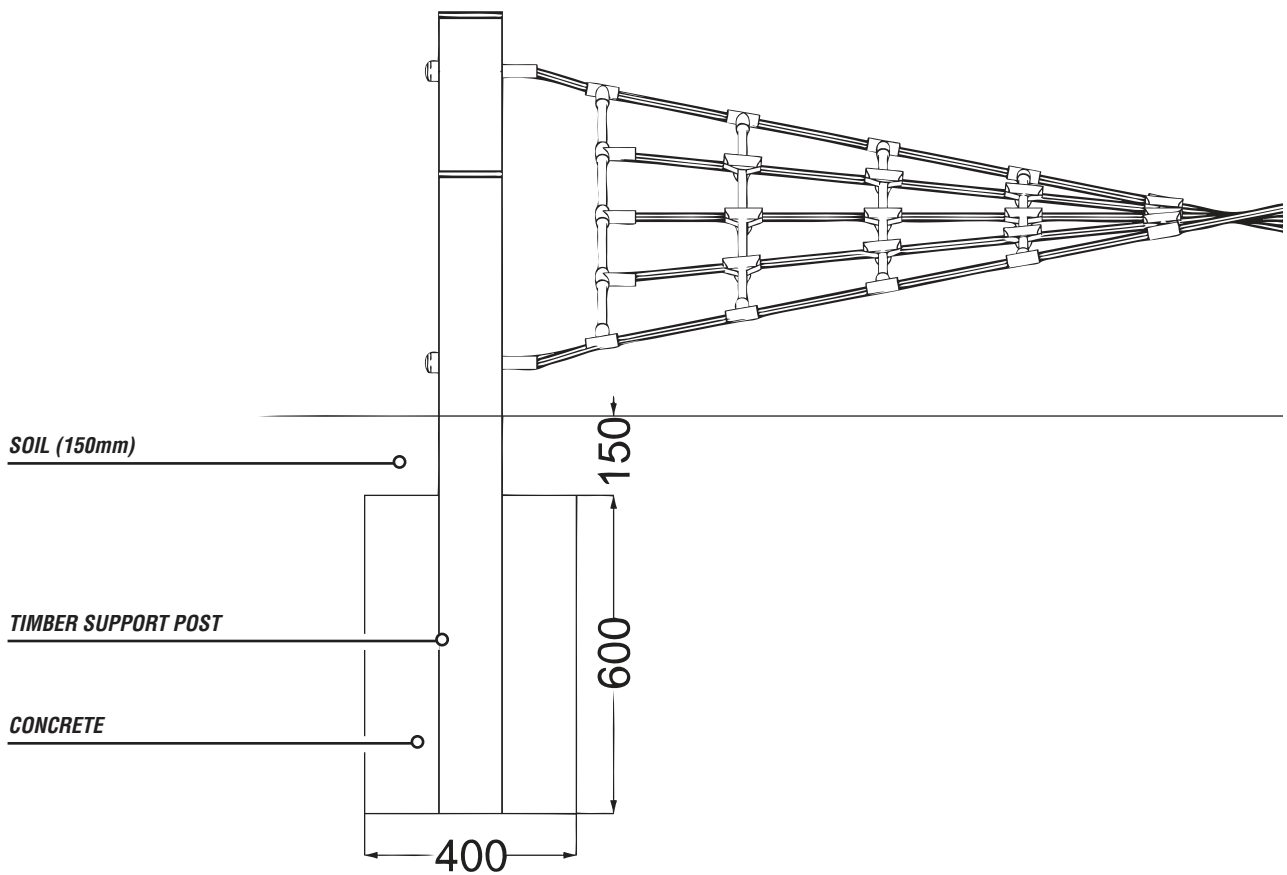
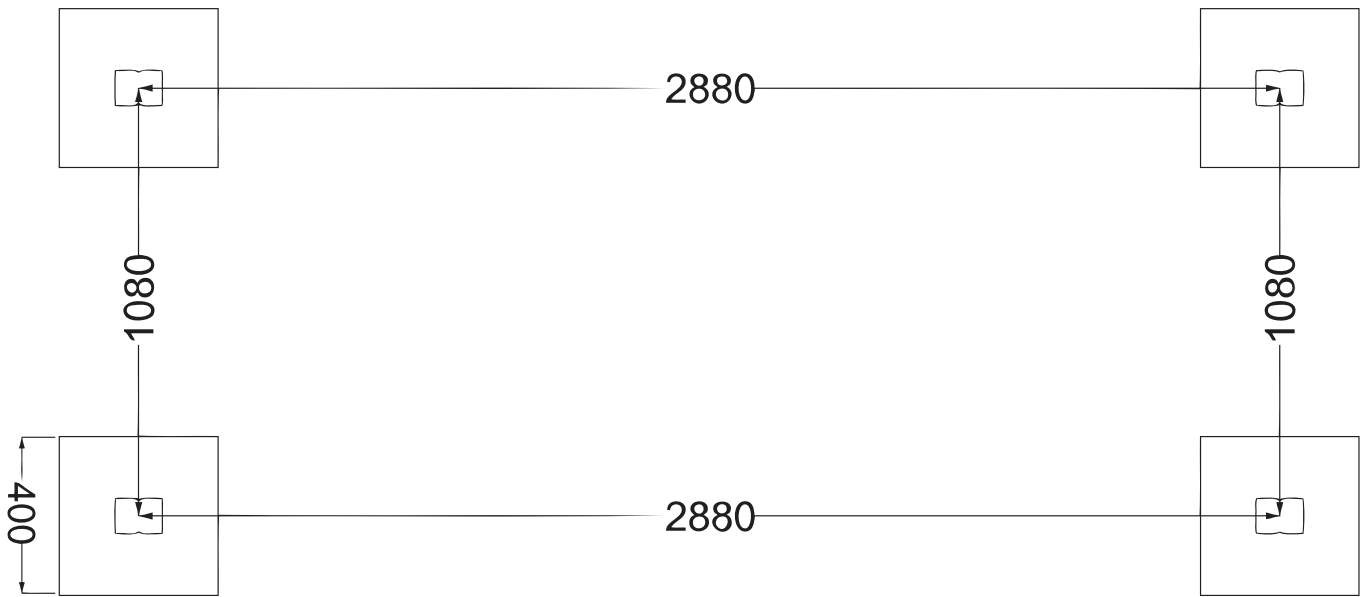

Assembly Instructions

1

Position TN1 & TN2 timbers

TN1 timbers are diagonally opposite each other

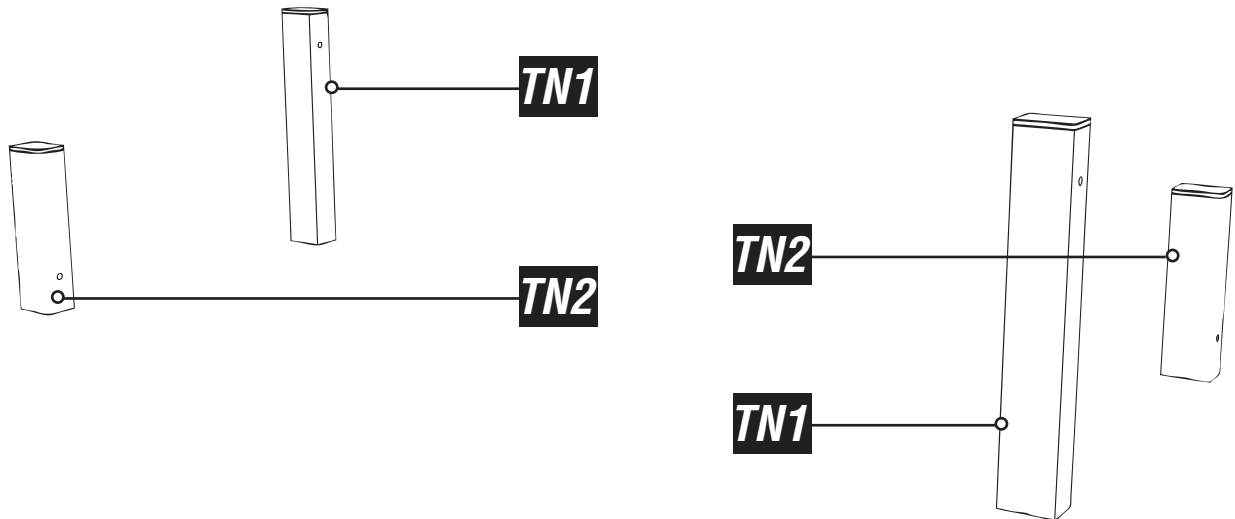

2

Bolt the net assembly to TN1 & TN2 timbers

Using nylocs

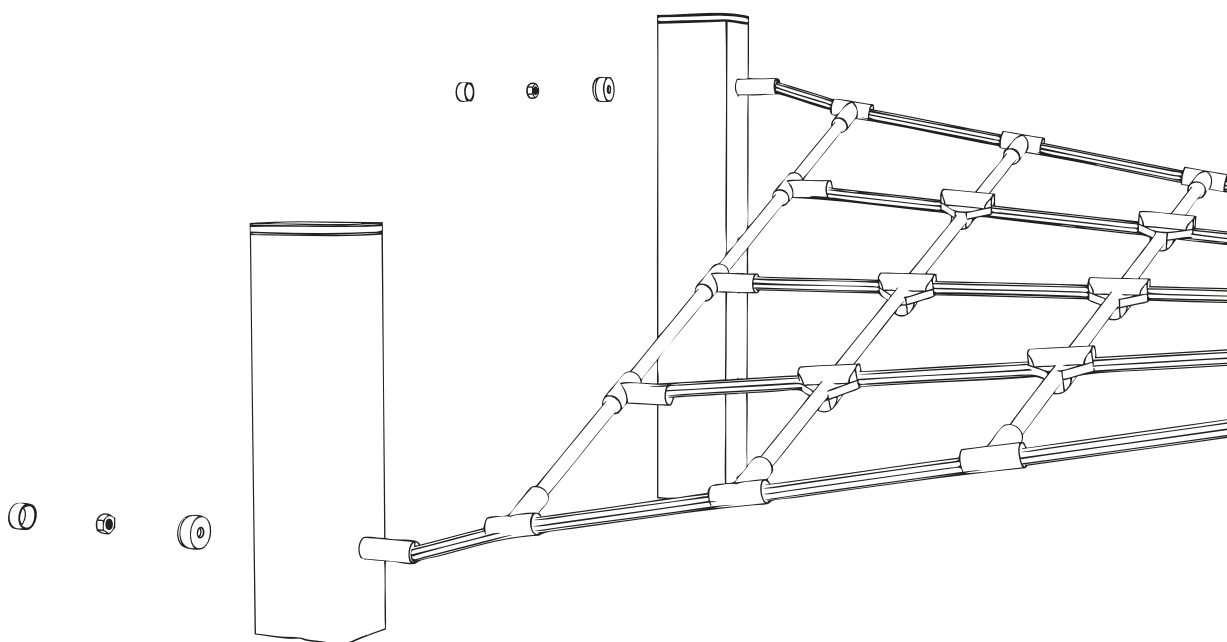

3

Ensure the net is correctly positioned

The net will be marked as shown below R1H (high) R1L (low)

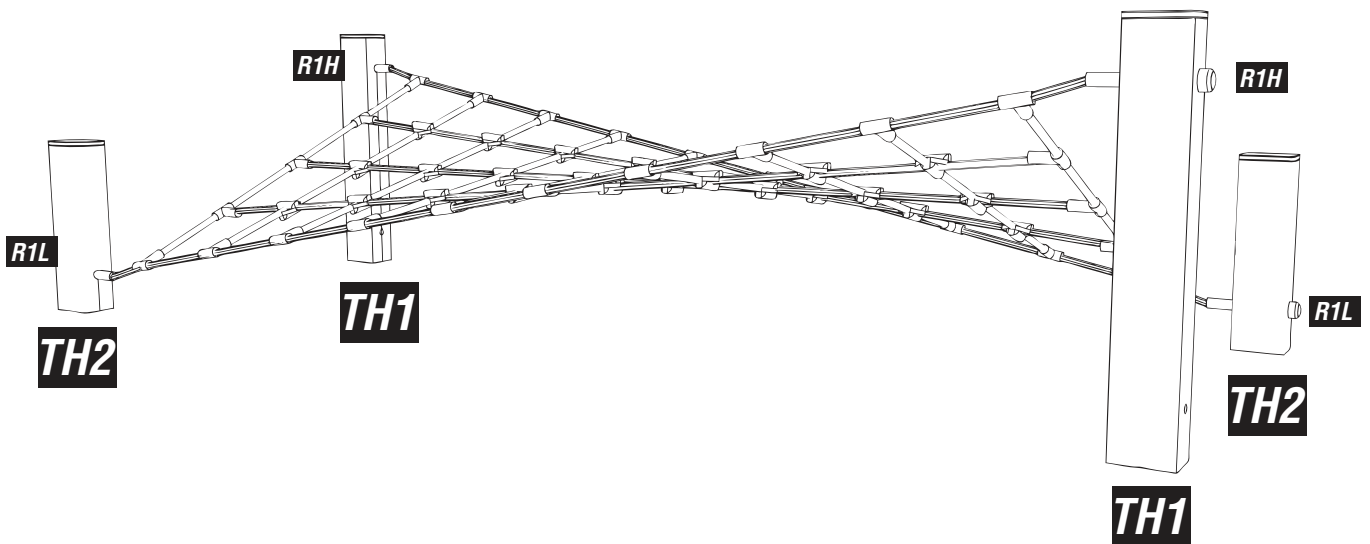
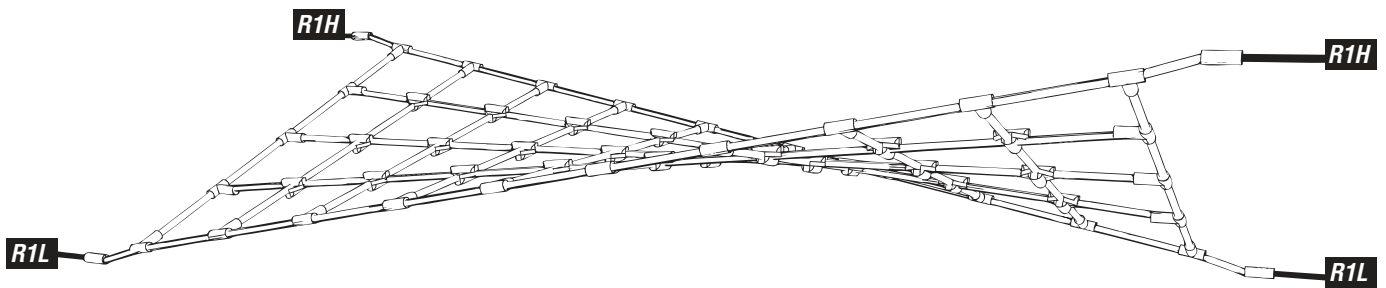

Dimensions

