

AT8-L - ADVENTURE TRAIL 8 - L SHAPED

Manufacturing Instructions

**creative
play**

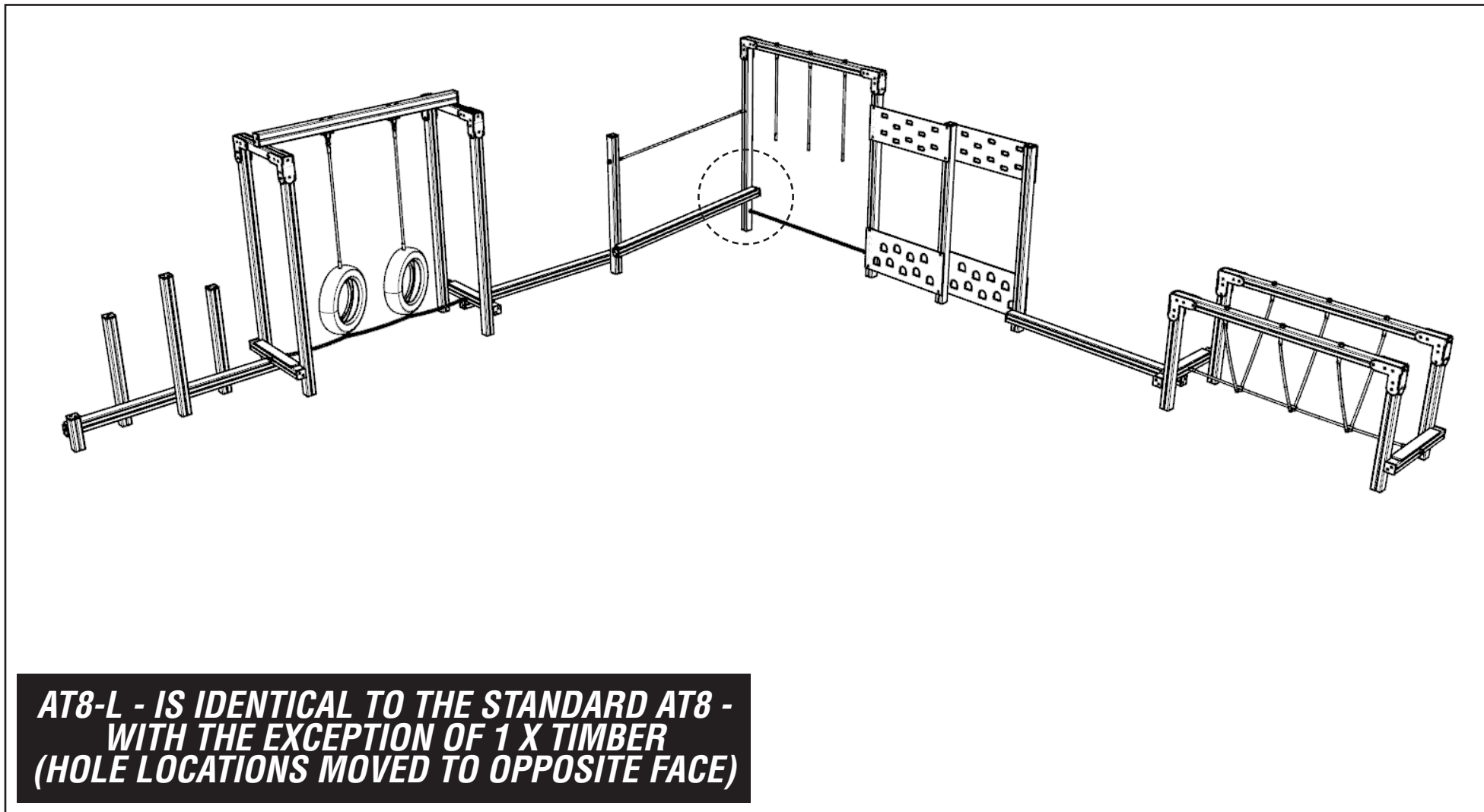

AT8-L - ADVENTURE TRAIL 8 - L SHAPED

Manufacturing Instructions

creative
play

AS PER STANDARD OTHER THAN 1 X TIMBER (SHOWN IN WHITE BOXES)

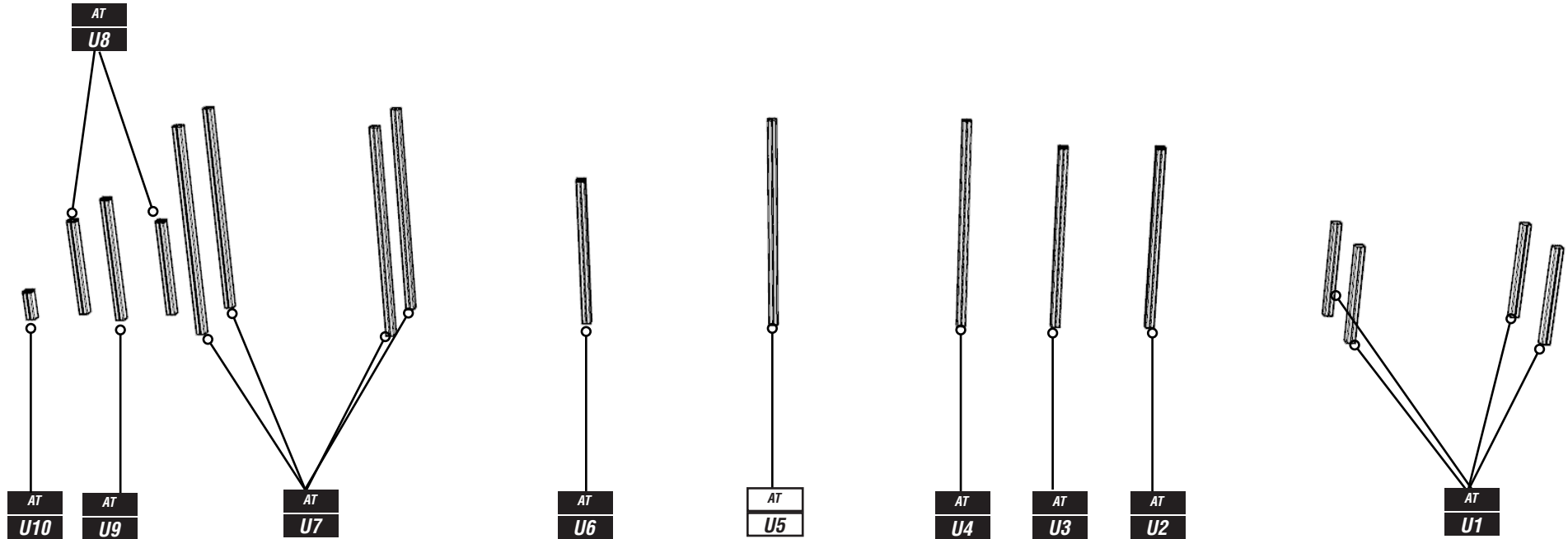

UPRIGHT TIMBERS

QTY: See individual notes
FINISH: N/A

NOTES: ALL HOLES 14mm
unless otherwise stated

DRAWN: PDS/KW 13.03.19
CHECKED: PDS 13.03.19
APPROVED: JH / DE

DRAWING NO.

AT8-L/2

AT8-L - ADVENTURE TRAIL 8 - L SHAPED

Manufacturing Instructions



AS PER STANDARD OTHER THAN 1 X TIMBER (SHOWN IN WHITE BOXES)

CODE	TYPE	SIZE	QTY	START	GROOVED FACE	PLANE FACE	END	ADDITIONAL INFORMATION
AT - U1	90x90	1800	4	-	-	1000	-	
AT - U2	90x90	2715	1	-	910	-	END CAP	UPRIGHT TIMBER
AT - U3	90x90	2715	1	-	-	-	END CAP	UPRIGHT TIMBER
AT - U4	90x90	3000	1	-	-	1000	-	UPRIGHT TIMBER
AT - U5	90x90	3000	1	-	2235	1000 1225	-	UPRIGHT TIMBER
AT - U6	90x90	2335	1	-	910 1033	2056	END CAP	UPRIGHT TIMBER
AT - U7	90x90	3000	4	-	-	1000	-	UPRIGHT TIMBER
AT - U8	90x90	1800	2	-	910	-	END CAP	UPRIGHT TIMBER
AT - U9	90x90	2100	1	-	910	-	END CAP	UPRIGHT TIMBER
AT - U10	90x90	1055	1	-	910	-	END CAP	UPRIGHT TIMBER

UNDERLINE - COUNTERBORE / HOLE
32-Ø - 20MM DEPTH

BOXED - THE 17MM BIT (SOCKET NUT)

QTY: See individual notes
FINISH: N/A

NOTES: ALL HOLES 14mm
unless otherwise stated

DRAWN: PDS/KW 13.03.19
CHECKED: PDS 13.03.19
APPROVED: JH / DE

DRAWING NO.

AT8-L/3

TIMBERS

AT8-L - ADVENTURE TRAIL 8 - L SHAPED

Manufacturing Instructions

**creative
play**

AS PER STANDARD OTHER THAN 1 X TIMBER (SHOWN IN WHITE BOXES)

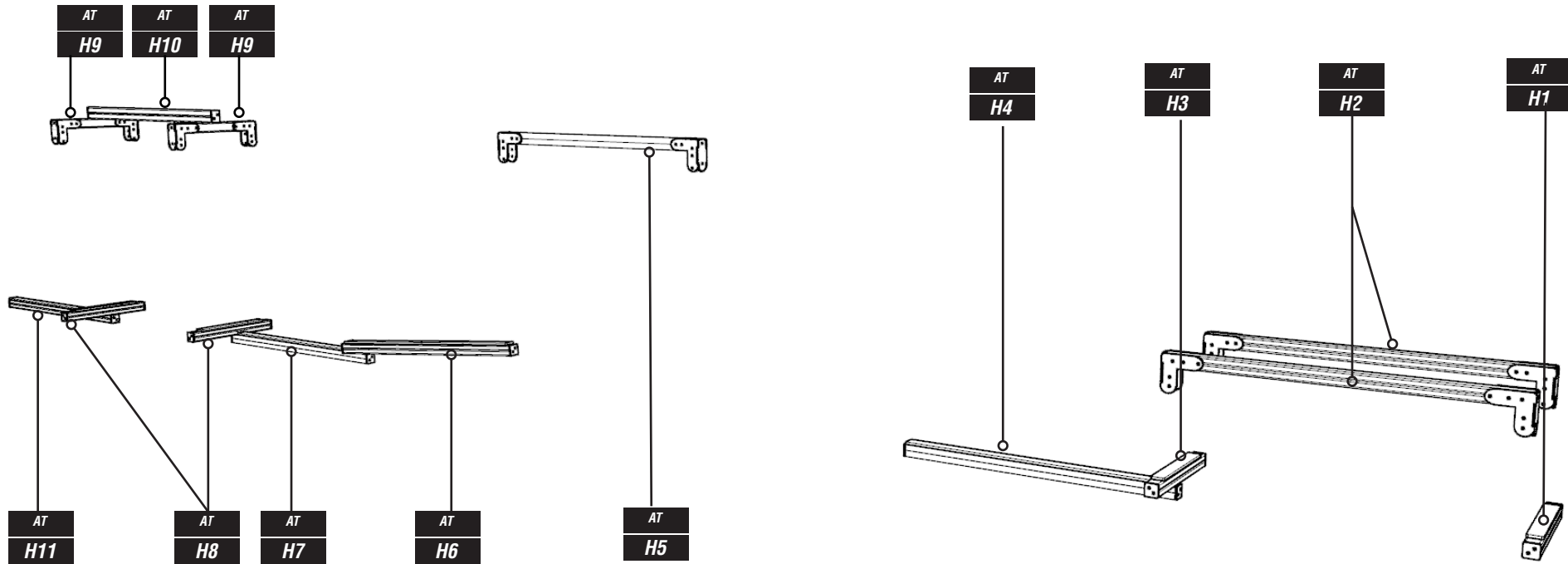

HORIZONTAL TIMBERS

QTY: See individual notes
FINISH: N/A

NOTES: ALL HOLES 14mm
unless otherwise stated

DRAWN: PDS/KW 13.03.19
CHECKED: PDS 13.03.19
APPROVED: JH / DE

DRAWING NO.
AT8-L/4

AT8-L - ADVENTURE TRAIL 8 - L SHAPED

Manufacturing Instructions



AS PER STANDARD OTHER THAN 1 X TIMBER (SHOWN IN WHITE BOXES)

CODE	TYPE	SIZE	QTY	START	GROOVED FACE	PLANE FACE	END	ADDITIONAL INFORMATION
AT - H1	90x90	900	1	END CAP	45 450 855	-	END CAP	HORIZONTAL TIMBER (HEXA GRIP SLAT)
AT - H2	90x90	2100	2	PLAYTEC L'S	-	535 1060 1585	PLAYTEC L'S (90x90)	SEE DRAWING
AT - H3	90x90	900	1	END CAP	45 450 855	<u>540</u>	END CAP	HORIZONTAL TIMBER (HEXA GRIP SLAT)
AT - H4	90x90	2010	1	END CAP	45	1965	END CAP	HORIZONTAL TIMBER (HEXA GRIP SLAT)
AT - H5	90x90	2100	1	PLAYTEC L'S	-	525 1050 1575	PLAYTEC L'S (90x90)	SEE DRAWING
AT - H6	90x90	2160	1	END CAP	65 2085	-	END CAP	HORIZONTAL TIMBER (HEXA GRIP SLAT)

TIMBERS

**UNDERLINE - COUNTERBORE / HOLE
32-Ø - 20MM DEPTH**

QTY: See individual notes
FINISH: N/A
NOTES: ALL HOLES 14mm
unless otherwise stated

DRAWN: PDS/KW 13.03.19
CHECKED: PDS 13.03.19
APPROVED: JH / DE

DRAWING NO.
AT8-L/5

AT8-L - ADVENTURE TRAIL 8 - L SHAPED

Manufacturing Instructions



AS PER STANDARD OTHER THAN 1 X TIMBER (SHOWN IN WHITE BOXES)

CODE	TYPE	SIZE	QTY	START	GROOVED FACE	PLANE FACE	END	ADDITIONAL INFORMATION
AT - H7	90x90	2010	1	END CAP	1965	45	END CAP	HORIZONTAL TIMBER (HEXA GRIP SLAT)
AT - H8	90x90	900	2	END CAP	45 <u>450</u> 855	<u>540</u>	END CAP	HORIZONTAL TIMBER (HEXA GRIP SLAT)
AT - H9	90x90	900	2	PLAYTEC L'S	450	-	PLAYTEC L'S	HORIZONTAL TIMBER
AT - H10	90X120	2100	1	END CAP 90X120	-	45 652 742 1358 1448 2055	END CAP 90X120	ATTACH SWING HANGER FOR TYRE CROSSING (SEE DRAWING)
AT - H11	90X90	2010	1	END CAP	45 540 1020 1500	1965	END CAP	HORIZONTAL TIMBER (HEXA GRIP SLAT)

TIMBERS

**UNDERLINE - COUNTERBORE / HOLE
32-Ø - 20MM DEPTH**

QTY: See individual notes FINISH: N/A NOTES: ALL HOLES 14mm unless otherwise stated	DRAWN: PDS/KW 13.03.19 CHECKED: PDS 13.03.19 APPROVED: JH / DE	DRAWING NO. AT8-L/6
--	--	-----------------------------------

AT8-L - ADVENTURE TRAIL 8 - L SHAPED

Manufacturing Instructions

creative
play

AS PER STANDARD OTHER THAN 1 X TIMBER (SHOWN IN WHITE BOXES)

CNC PROGRAM SHEET HAS THE TIMBER CODE WRITTEN / LABELLED

PLEASE NOTE THAT SOME HOLES ARE 'OFFSET' PLEASE ENSURE THE CORRECT SIDES / FACES ARE USED

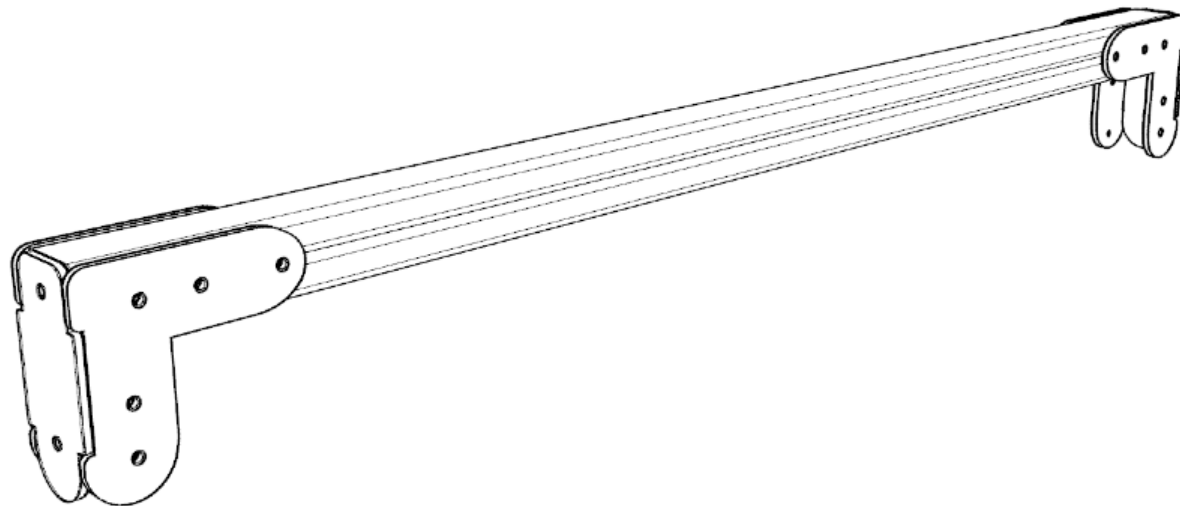
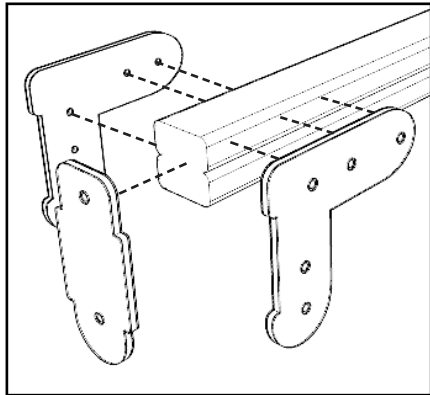

QUANTITY x 5

H2 2 X H2 TIMBERS

H5 1 X H5 TIMBER

H9 2 X H9 TIMBER

PRE-ASSEMBLE - ATTACH THE L'S / T'S TO THE TIMBERS USING 8X80 WOOD SCREWS

QTY: See individual notes
FINISH: N/A

DRAWN: PDS/KW 13.03.19
CHECKED: PDS 13.03.19
APPROVED: JH / DE

NOTES: ALL HOLES 14mm
unless otherwise stated

DRAWING NO.

AT8-L/7

PRE-ASSEMBLY

AT8-L - ADVENTURE TRAIL 8 - L SHAPED

Manufacturing Instructions

creative
play

AS PER STANDARD OTHER THAN 1 X TIMBER (SHOWN IN WHITE BOXES)

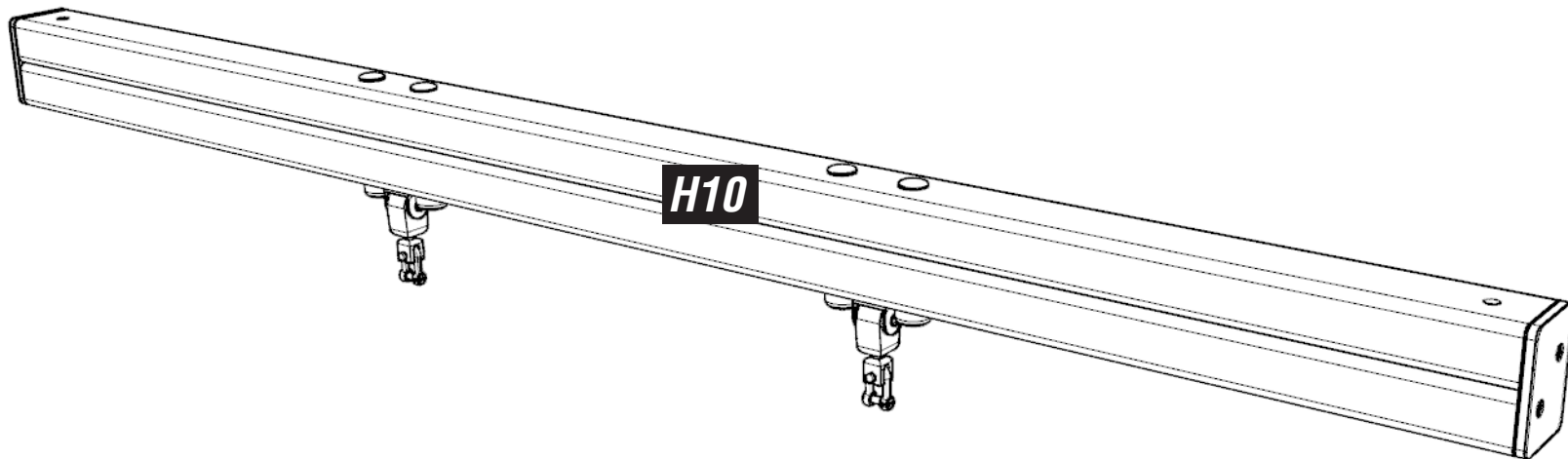

NOTES:

ATTACH SWING HANGERS
AS SHOWN

PRE-ASSEMBLY

**PRE-ASSEMBLE - ATTACH 2 SWING
HANGERS TO TIMBER H10**

QTY: See individual notes
FINISH: N/A

NOTES: ALL HOLES 14mm
unless otherwise stated

DRAWN: PDS/KW 13.03.19
CHECKED: PDS 13.03.19
APPROVED: JH / DE

DRAWING NO.

AT8-L/8

AT8-L - ADVENTURE TRAIL 8 - L SHAPED

Manufacturing Instructions

creative
play

AS PER STANDARD OTHER THAN 1 X TIMBER (SHOWN IN WHITE BOXES)

CNC PROGRAM SHEET HAS THE TIMBER CODE WRITTEN / LABELLED

CENTRE HEXBOARD ON TIMBER PLANE FACE AS SHOWN

QUANTITY x 4

H1 X1 - AS SHOWN BELOW

H3 X3 - DO NOT PRE-ASSEMBLE, LEAVE HEX BOARD LOOSE FOR SITE ASSEMBLY (DUE TO COUNTERSINK)

H8

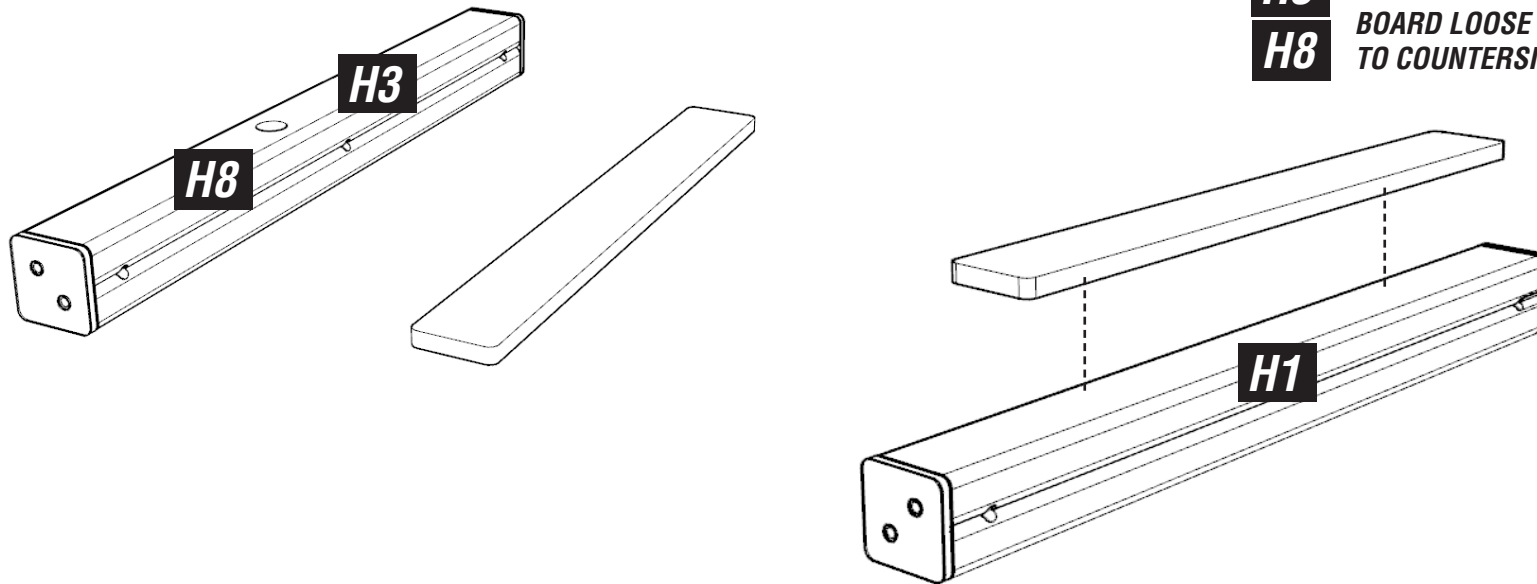

PRE-ASSEMBLY

PRE-ASSEMBLE - ATTACH THE HEX-BOARD USING 8X80 WOOD SCREWS

QTY: See individual notes
FINISH: N/A
NOTES: ALL HOLES 14mm unless otherwise stated

DRAWN: PDS/KW 13.03.19
CHECKED: PDS 13.03.19
APPROVED: JH / DE

DRAWING NO.
AT8-L/9

AT8-L - ADVENTURE TRAIL 8 - L SHAPED

Manufacturing Instructions

creative
play

AS PER STANDARD OTHER THAN 1 X TIMBER (SHOWN IN WHITE BOXES)

CNC PROGRAM SHEET HAS THE TIMBER CODE WRITTEN / LABELLED

QUANTITY x 3

H4 X1 - AS SHOWN BELOW

H7 X1 - AS SHOWN BELOW

H11 X1 - AS SHOWN BELOW

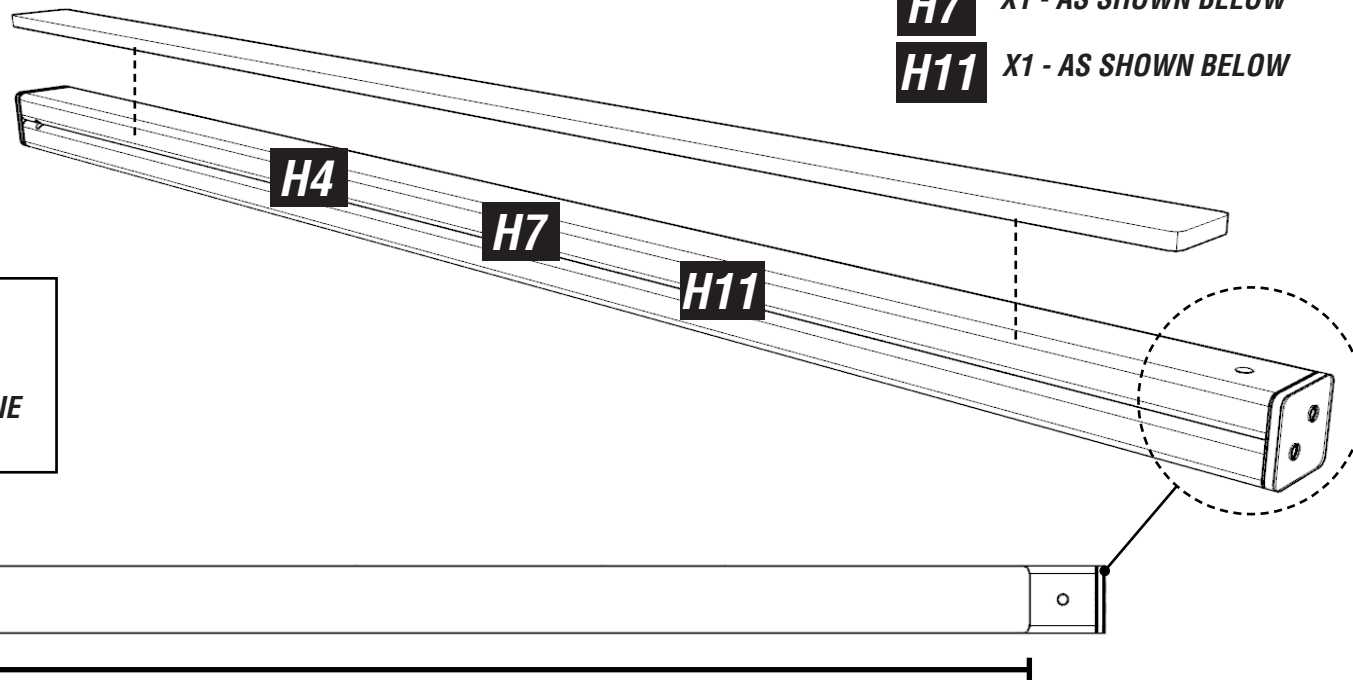

NOTES:

BUTT HEXBOARD UP TO END OF H4/H7/H11 TIMBERS (PLANE FACE) AS SHOWN BELOW

PRE-ASSEMBLY

PRE-ASSEMBLE - ATTACH THE HEXBOARD USING 8X80 WOOD SCREWS

QTY: See individual notes
FINISH: N/A

NOTES: ALL HOLES 14mm
unless otherwise stated

DRAWN: PDS/KW 13.03.19
CHECKED: PDS 13.03.19
APPROVED: JH / DE

DRAWING NO.

AT8-L/10

AT8-L - ADVENTURE TRAIL 8 - L SHAPED

Manufacturing Instructions

creative
play

AS PER STANDARD OTHER THAN 1 X TIMBER (SHOWN IN WHITE BOXES)

CNC PROGRAM SHEET HAS THE TIMBER CODE WRITTEN / LABELLED

QUANTITY x 1

H6 X1 - AS SHOWN BELOW

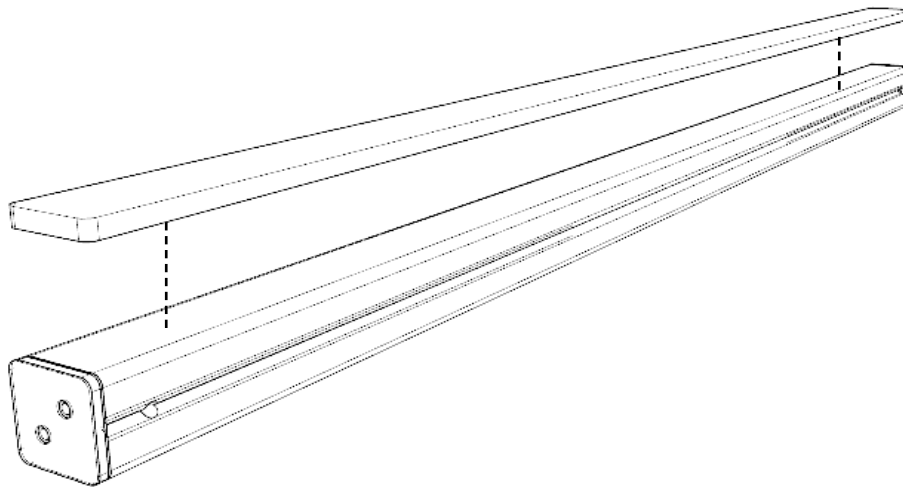

NOTES:

**CENTRE HEXBOARD ON TIMBER
PLANE FACE AS SHOWN**

PRE-ASSEMBLY

**PRE-ASSEMBLE - ATTACH THE HEX-
BOARD USING 8X80 WOOD SCREWS**

QTY: See individual notes
FINISH: N/A

NOTES: ALL HOLES 14mm
unless otherwise stated

DRAWN: PDS/KW 13.03.19
CHECKED: PDS 13.03.19
APPROVED: JH / DE

DRAWING NO.

AT8-L/11

AT8-L - ADVENTURE TRAIL 8 - L SHAPED

Manufacturing Instructions

creative
play

AS PER STANDARD OTHER THAN 1 X TIMBER (SHOWN IN WHITE BOXES)

R1 3 X ROPE @ 1000
(121 THREAD / BLACK CAP)

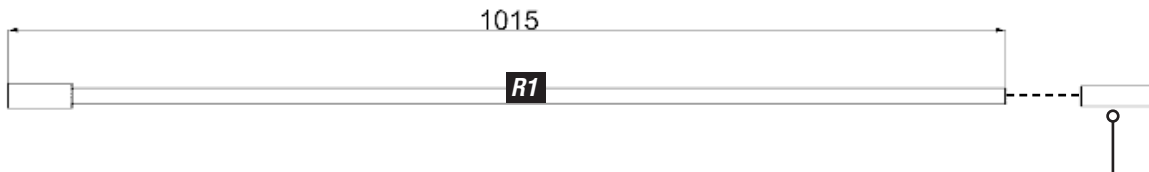

QUANTITY x 3

STD FERRULE

-15MM FOR EACH FERRULE (THREAD BAR)

NOTES - ATTACH THE BLACK CAP - 'HEAT SHRINK' ONTO END OF ROPE

C1 1 X CHAIN @ 1920MM

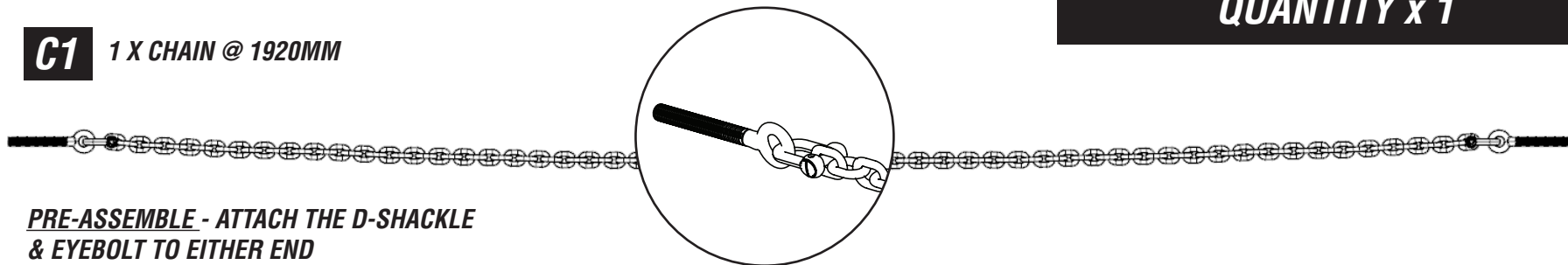

PRE-ASSEMBLE - ATTACH THE D-SHACKLE & EYEBOLT TO EITHER END

QUANTITY x 1

ROPE WALK - ROPES / NETS

QTY: See individual notes
FINISH: N/A

NOTES: ALL HOLES 14mm
unless otherwise stated

DRAWN: PDS/KW 13.03.19
CHECKED: PDS 13.03.19
APPROVED: JH / DE

DRAWING NO.

AT8-L/12

AT8-L - ADVENTURE TRAIL 8 - L SHAPED

Manufacturing Instructions

creative
play

AS PER STANDARD OTHER THAN 1 X TIMBER (SHOWN IN WHITE BOXES)

QUANTITY x 1

R1 1 X ROPE @ 1900
(121 THREAD / 121 THREAD)

STD FERRULE

-15MM FOR EACH FERRULE (THREAD BAR)

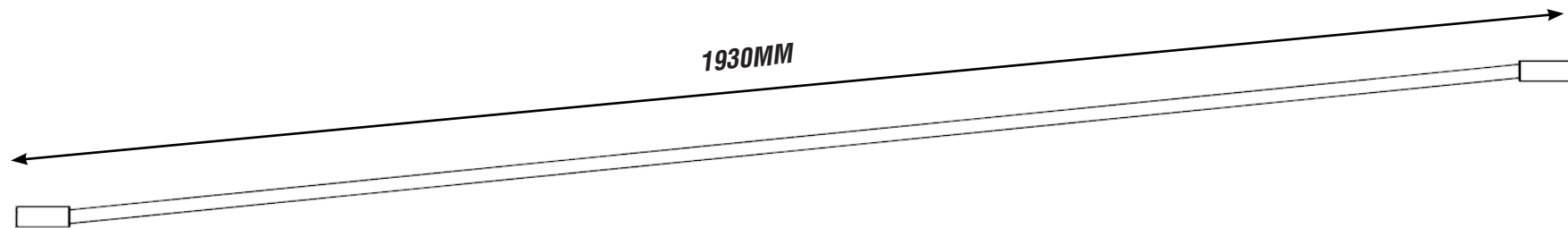

INCLINED TRAVERSE ROPE - ROPES / NETS

QTY: See individual notes
FINISH: N/A

DRAWN: PDS/KW 13.03.19
CHECKED: PDS 13.03.19
APPROVED: JH / DE

DRAWING NO.

AT8-L/13

NOTES: ALL HOLES 14mm
unless otherwise stated

AT8-L - ADVENTURE TRAIL 8 - L SHAPED

Manufacturing Instructions

creative
play

AS PER STANDARD OTHER THAN 1 X TIMBER (SHOWN IN WHITE BOXES)

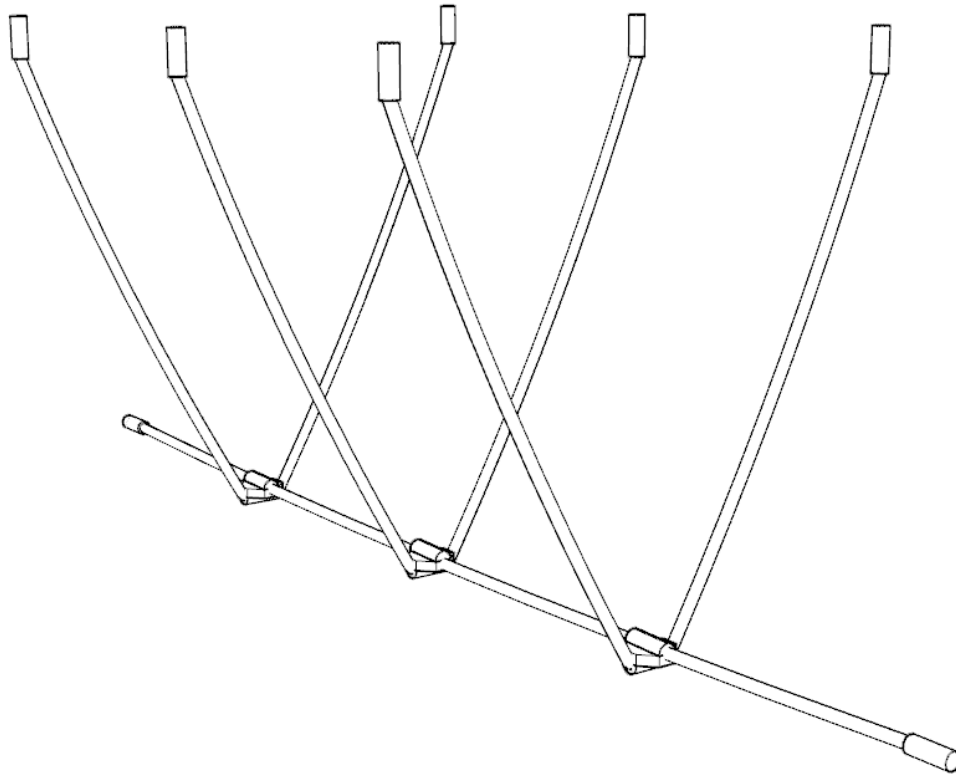

QUANTITY x 1

STD FERRULE x8

-15MM FOR EACH FERRULE (THREAD BAR)



x3 (X connector)

INCLINED TRAVERSE ROPE - ROPES / NETS

QTY: See individual notes
FINISH: N/A

NOTES: ALL HOLES 14mm
unless otherwise stated

DRAWN: PDS/KW 13.03.19
CHECKED: PDS 13.03.19
APPROVED: JH / DE

DRAWING NO.

AT8-L/14

AT8-L - ADVENTURE TRAIL 8 - L SHAPED

Manufacturing Instructions

creative
play

AS PER STANDARD OTHER THAN 1 X TIMBER (SHOWN IN WHITE BOXES)

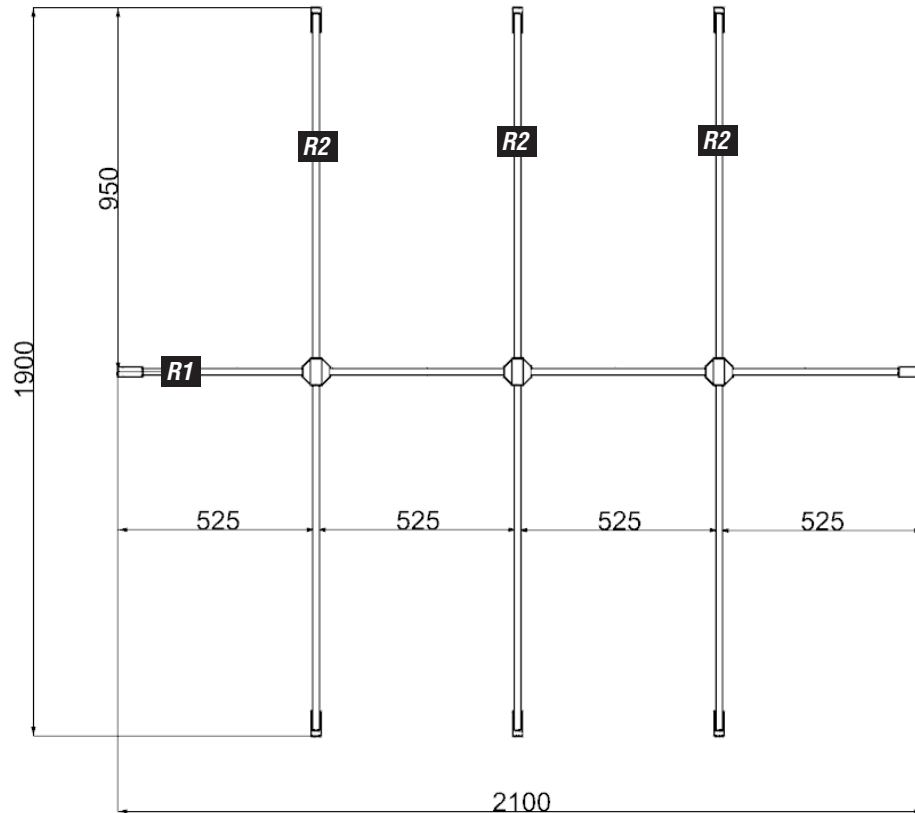

QUANTITY x 1

R1 1 X ROPE @ 2070
(121 THREAD / 121 THREAD)

R2 3 X ROPE @ 1870
(121 THREAD / 121 THREAD)

ROPE BRIDGE - ROPES / NETS

QTY: See individual notes
FINISH: N/A
NOTES: ALL HOLES 14mm
unless otherwise stated

DRAWN: PDS/KW 13.03.19
CHECKED: PDS 13.03.19
APPROVED: JH / DE

DRAWING NO.
AT8-L/15

AT8-L - ADVENTURE TRAIL 8 - L SHAPED

Manufacturing Instructions

creative
play

AS PER STANDARD OTHER THAN 1 X TIMBER (SHOWN IN WHITE BOXES)

QUANTITY x 2

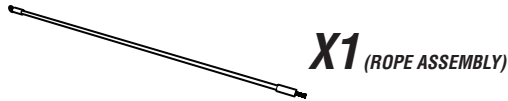
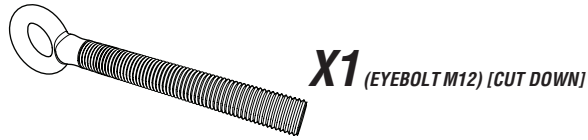

R1 2 X ROPE @ 1195MM
(EYEBOLT / THREADBAR)

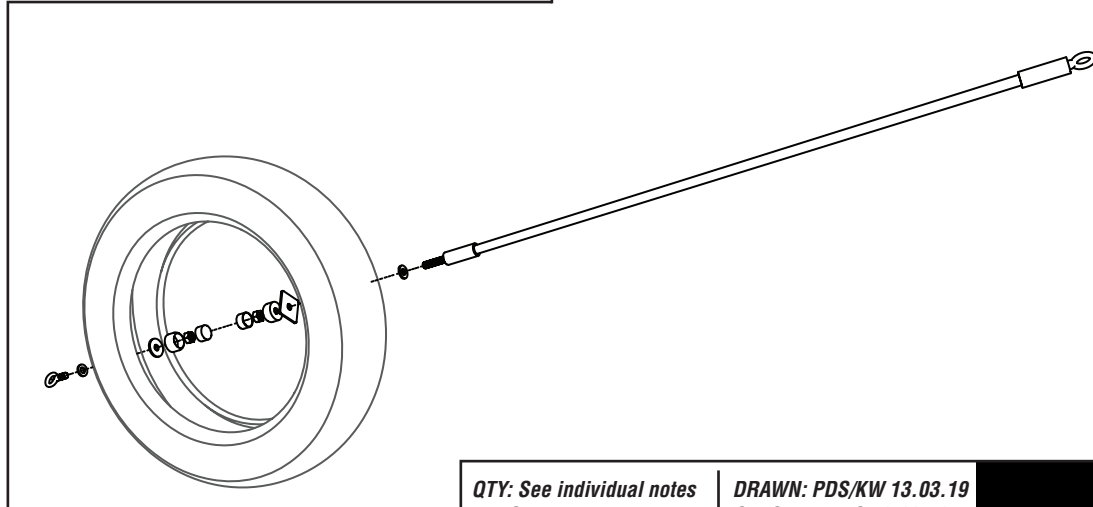
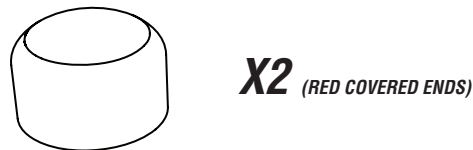

TYRES - ROPES / NETS

QTY: See individual notes
FINISH: N/A

DRAWN: PDS/KW 13.03.19
CHECKED: PDS 13.03.19
APPROVED: JH / DE

NOTES: ALL HOLES 14mm
unless otherwise stated

DRAWING NO.

AT8-L/16

AT8-L - ADVENTURE TRAIL 8 - L SHAPED

Manufacturing Instructions

creative
play

AS PER STANDARD OTHER THAN 1 X TIMBER (SHOWN IN WHITE BOXES)

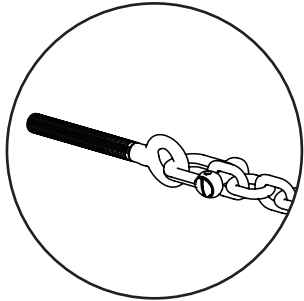

**PRE-ASSEMBLE - ATTACH THE D-SHACKLE
& EYEBOLT TO EITHER END**



QTY x 2



QTY x 1

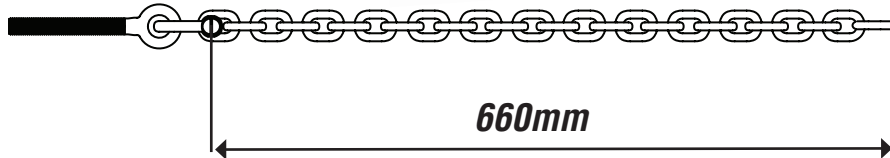

660mm

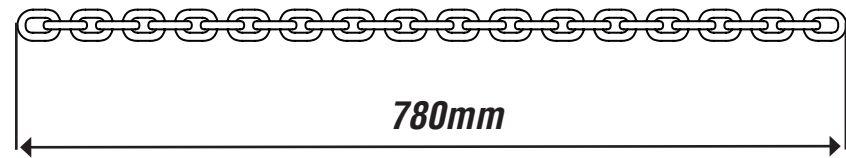

780mm

TYRES - ROPES / NETS

QTY: See individual notes
FINISH: N/A

NOTES: ALL HOLES 14mm
unless otherwise stated

DRAWN: PDS/KW 13.03.19
CHECKED: PDS 13.03.19
APPROVED: JH / DE

DRAWING NO.

AT8-L/17