

S115-R - DOUBLE SWING ROUND COMBI SEAT

Installation Instructions

**creative
play**



PARTS REQUIRED

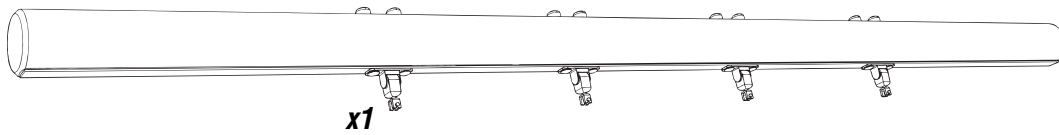

x1

TOP BEAM - SHORT S110R1



x4

UPRIGHTS S101R1



x2

FLAT SEAT INC CHAINS

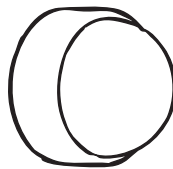

x8

BLACK M8 NUT CUP

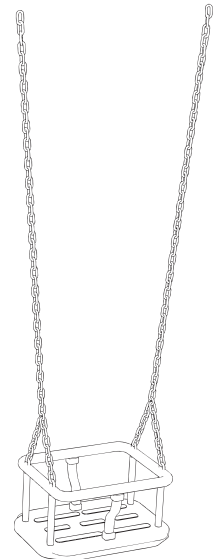

x2

CRADLE SEAT INC CHAINS

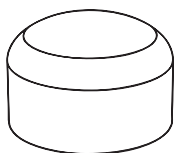

x6

END CAPS

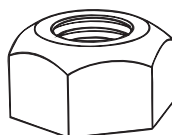

x6

M12 NYLOC NUT



x6

M12 x 320 SQUARE CUP BOLT

FOUNDATION DETAILS

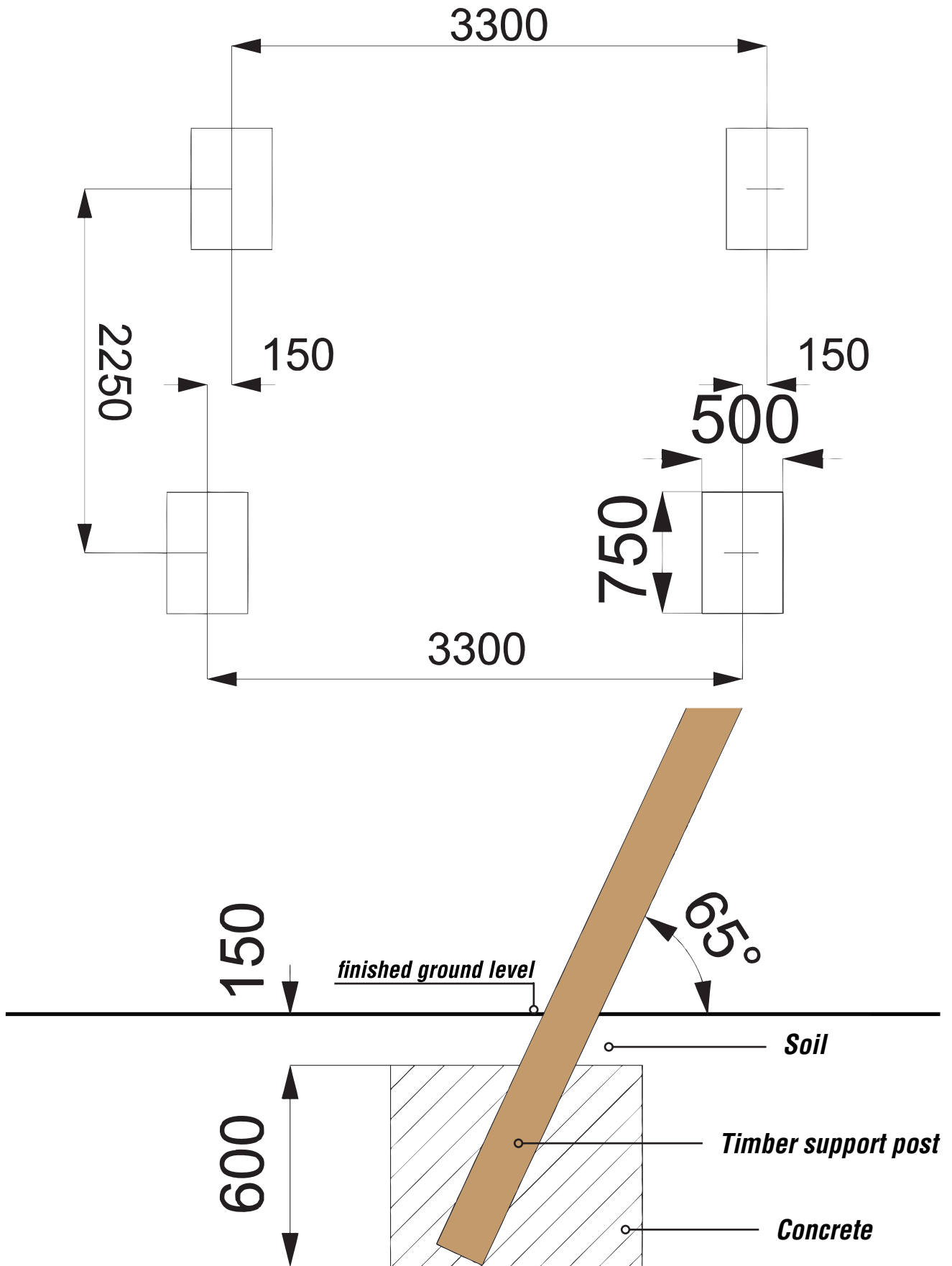

SURFACING DETAILS

- - - - = **MINIMUM SPACE**
- = **SURFACE AREA**
- = **SYNTHETIC**

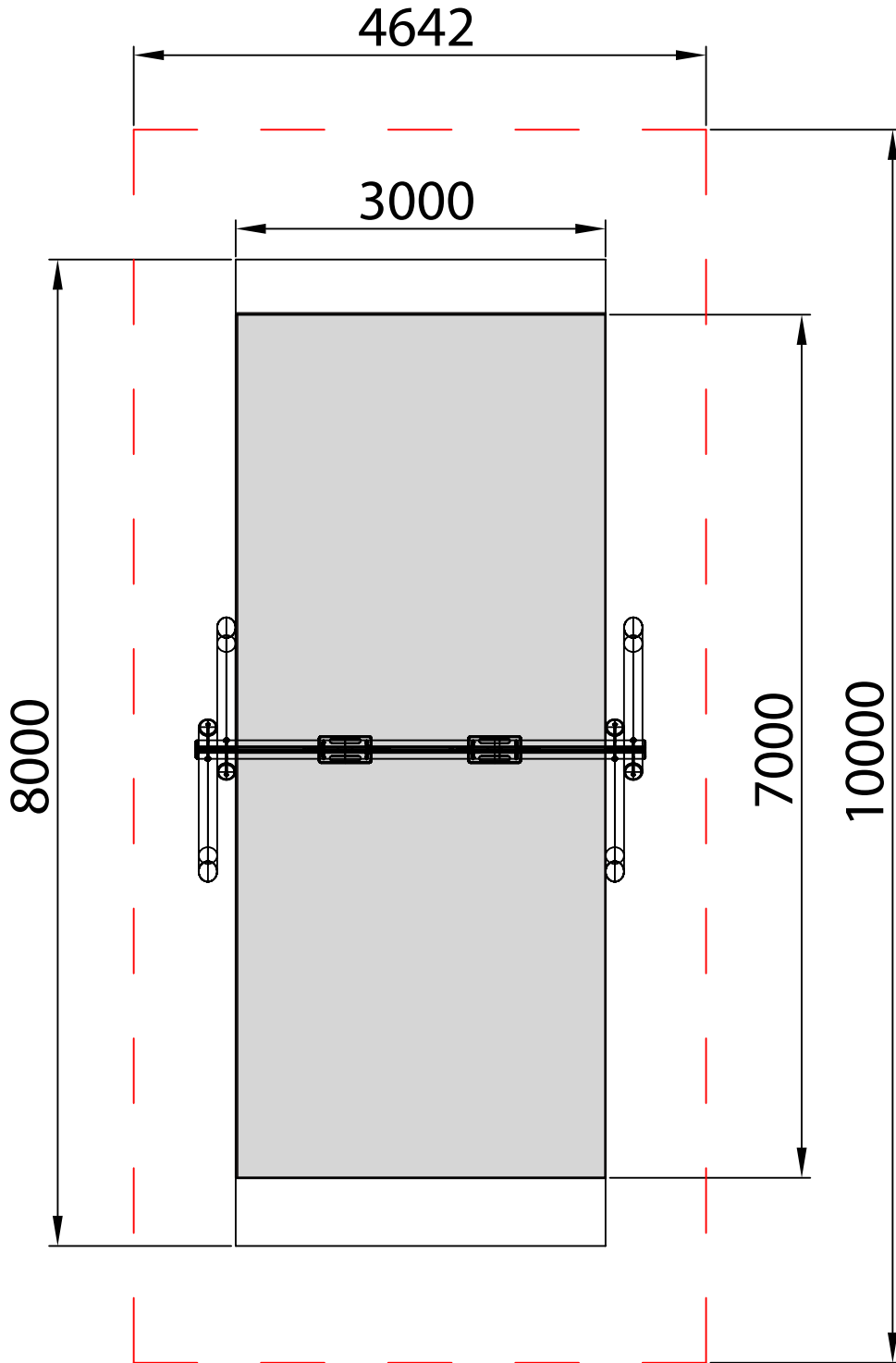

INSTALLATION INSTRUCTIONS

1

Build the SWING FRAME

Using (6x 310mm) M12 - square cup bolt / 6x NYLOCS / 6x Covered end cap R60

OUTSIDE TIMBERS

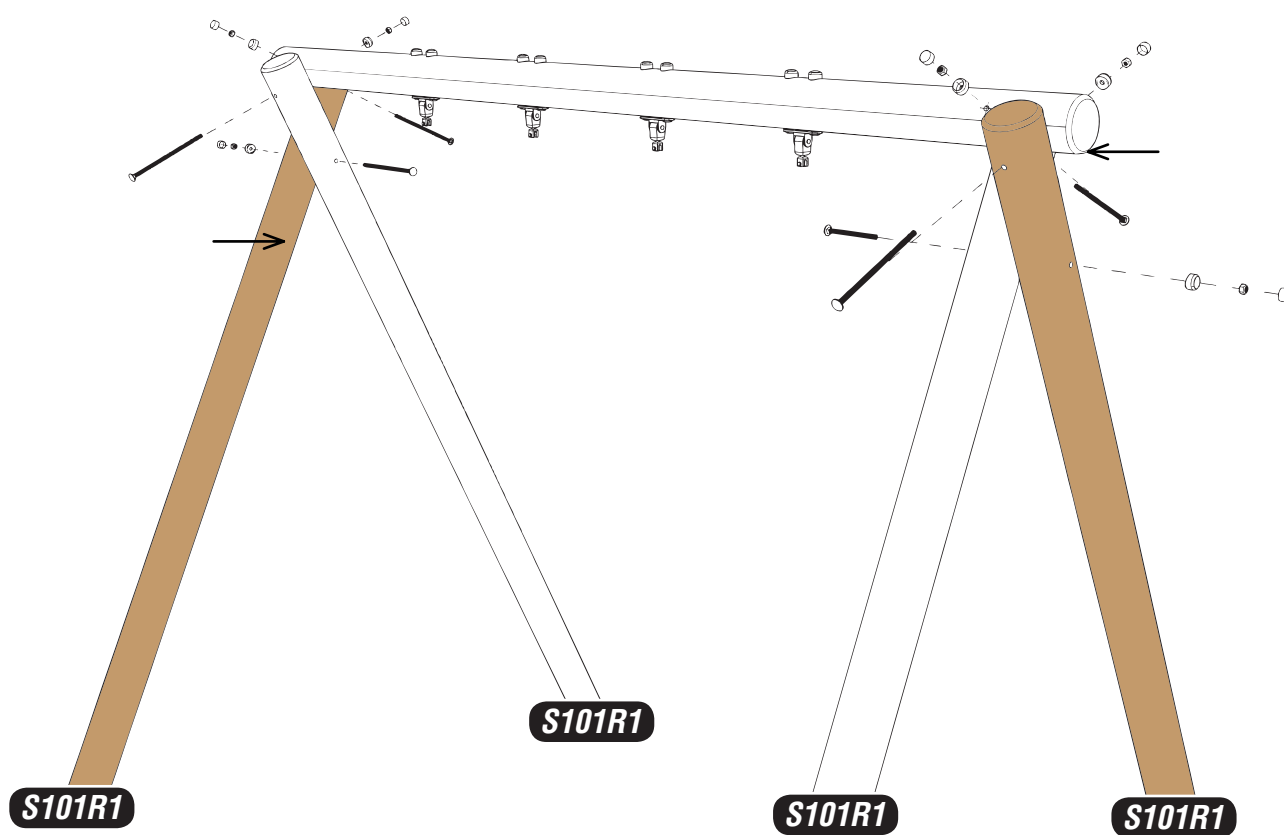

ENSURE:

TIMBERS ARE ATTACHED AS SHOWN ABOVE

INSTALLATION INSTRUCTIONS

2

Install Assembly

Follow Fundation details

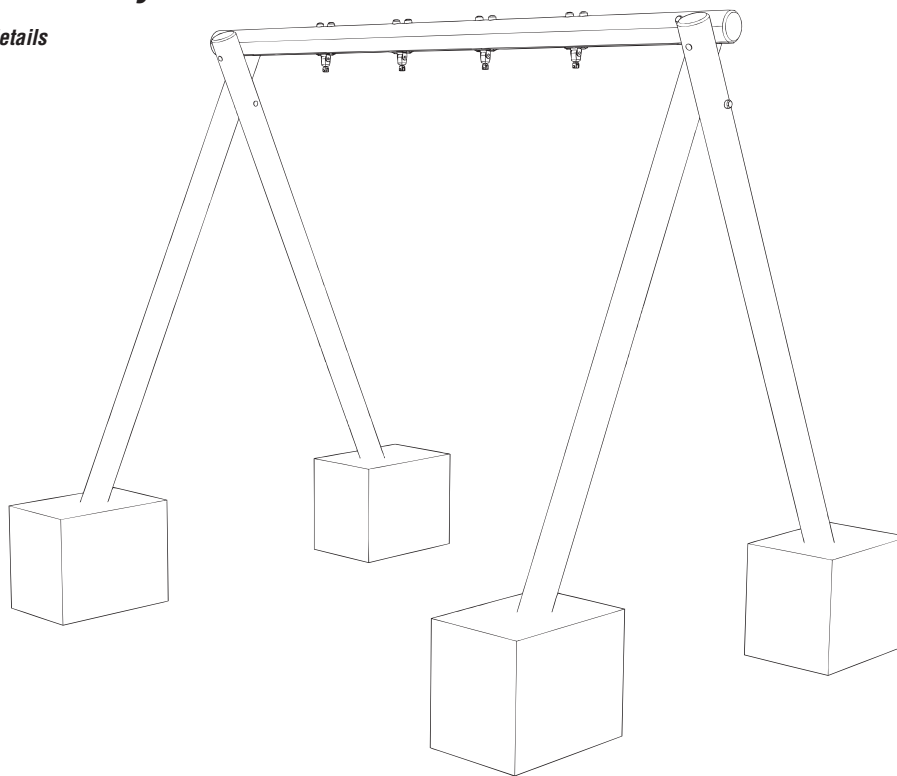

3

Install FLAT SEATS

USING M8 NUT CUP X8 . ADDITIONAL DIMENSIONS FOR SEAT HEIGHT

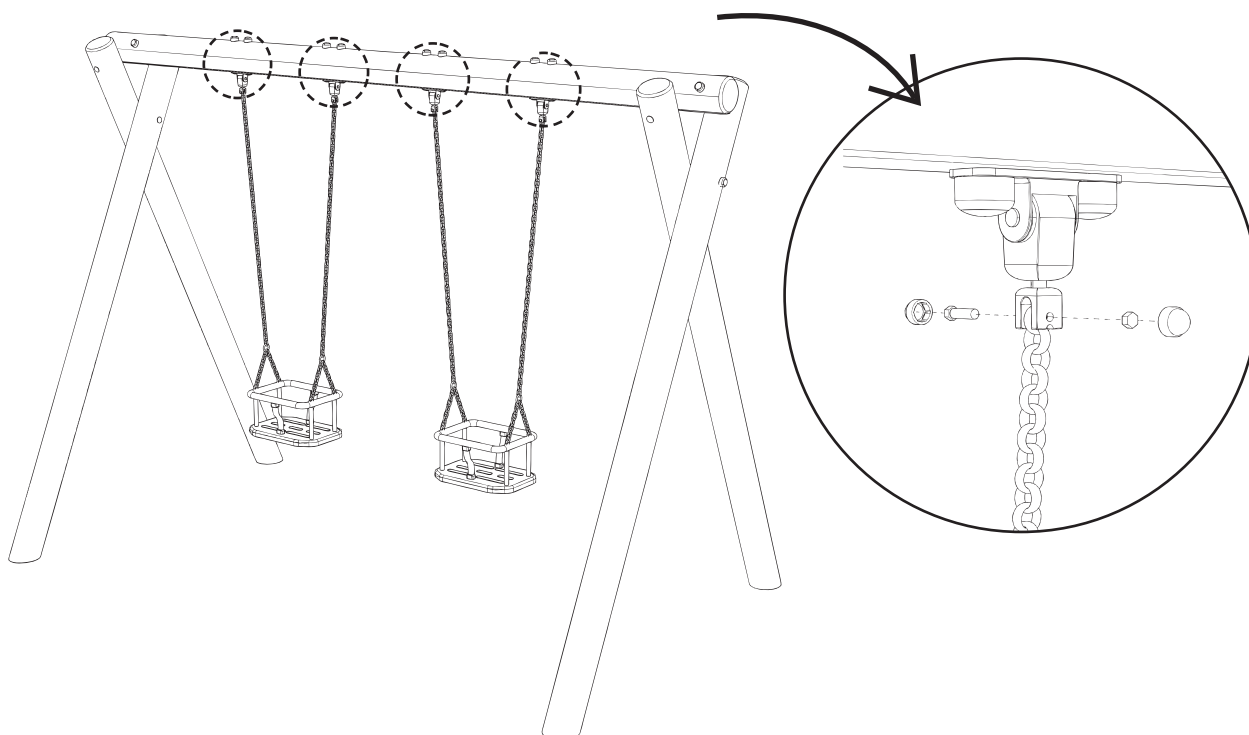

ADDITIONAL DIMENSIONS

