

S115 - DOUBLE SWING (COMBI SEAT)

Installation Instructions

**creative
play**



PARTS REQUIRED

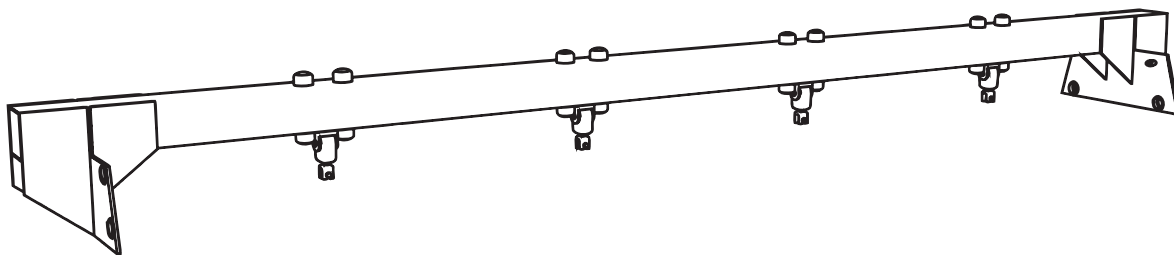

X1

DOUBLE SUPPORT BEAM



X4

M8X80 WOODSCREWS

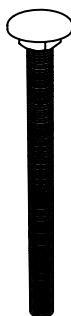

X8

M12X160 BOLT



X8

M12 END CAP



X1

CRADLE SEAT INC CHAINS

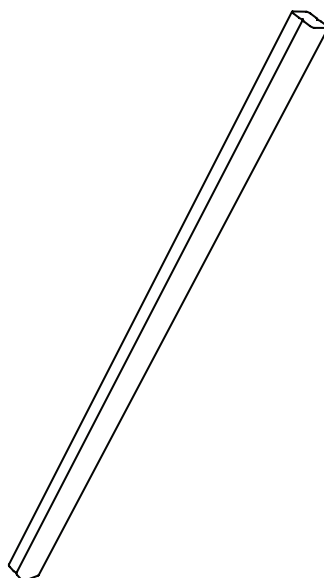

X4

S1 TIMBERS



X1

FLAT SEAT INC CHAINS

PARTS REQUIRED



X8

M8 NUT CAP

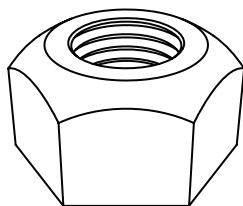

X8

M12 NYLOCS

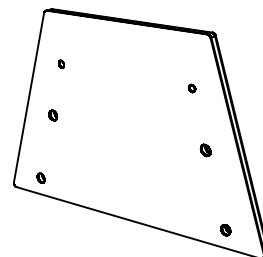



X2

PLAYTEC COVER

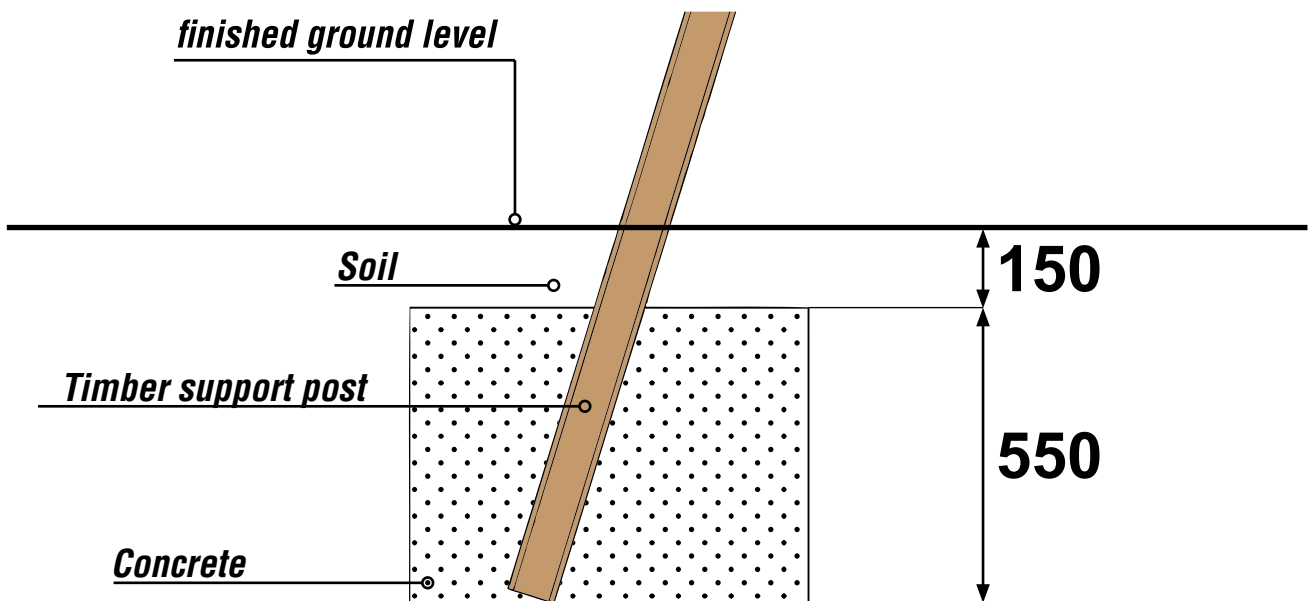
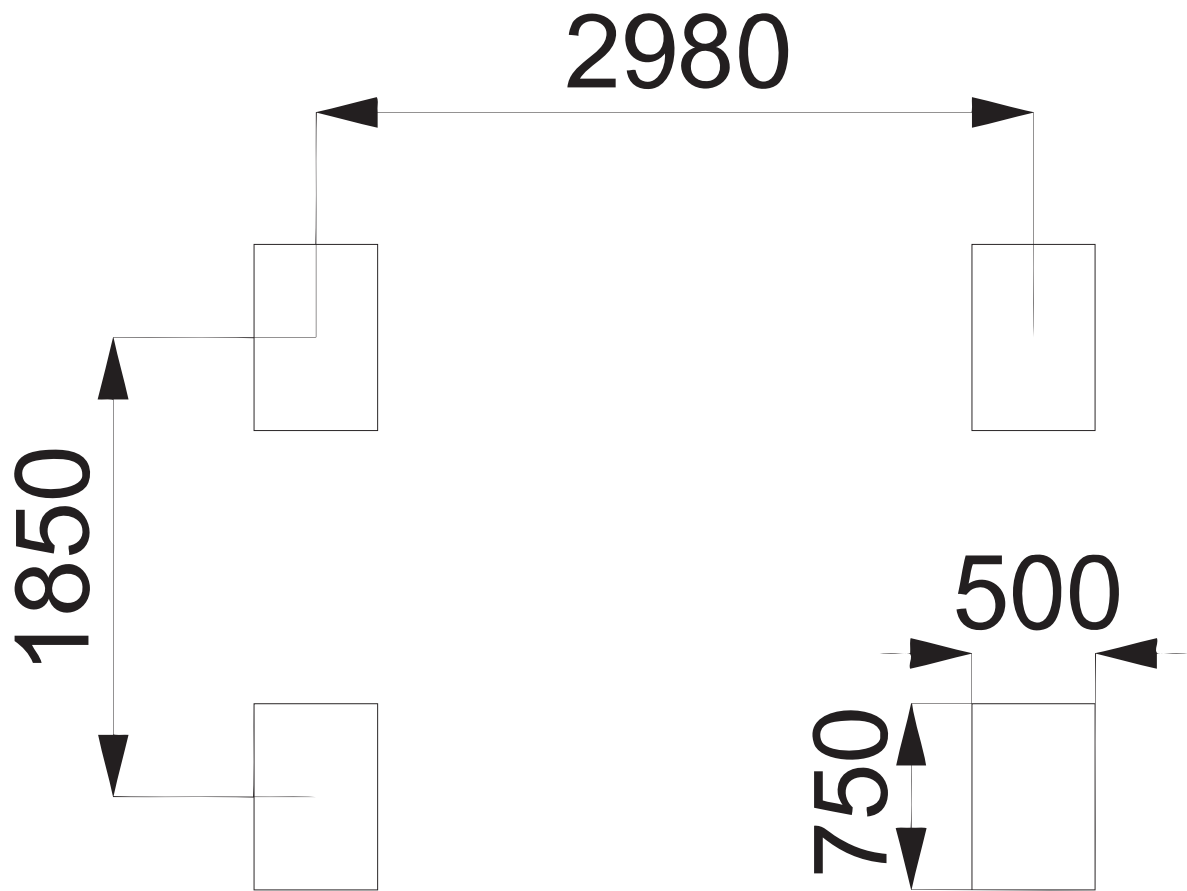
FOUNDATION DETAILS

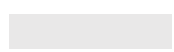

SURFACING DETAILS

-  = **SYNTHETIC**
-  = **LOOSE FILL**
-  = **AREA REQUIRED**

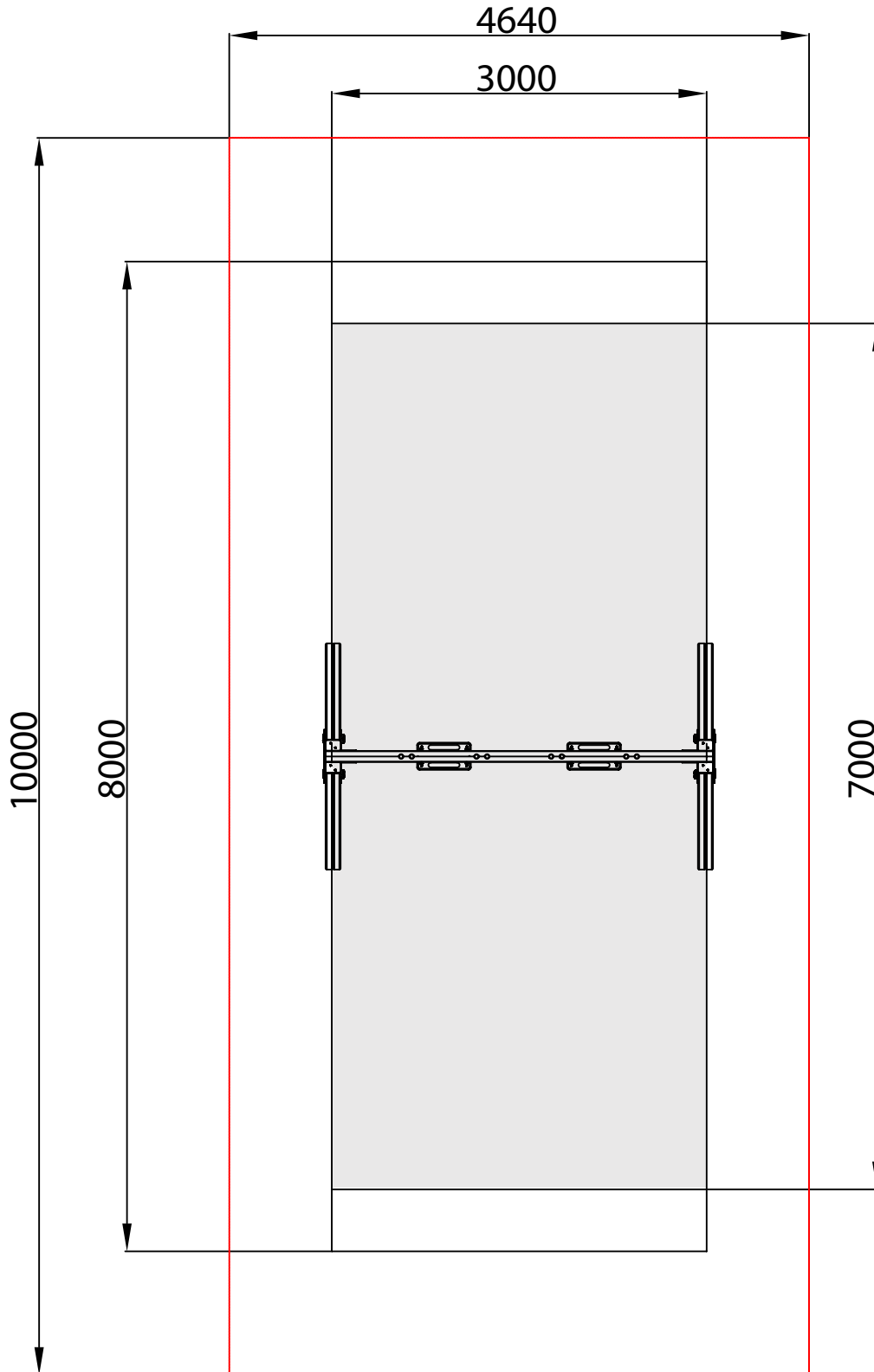

INSTALLATION INSTRUCTIONS

- 1** ATTACH PLAYTEC COVER AND S1 TIMBERS TO SUPPORT THE BEAM
USING M12X160 BOLTS [X8], M12 NYLOCS [X8] AND END CAPS [X8]

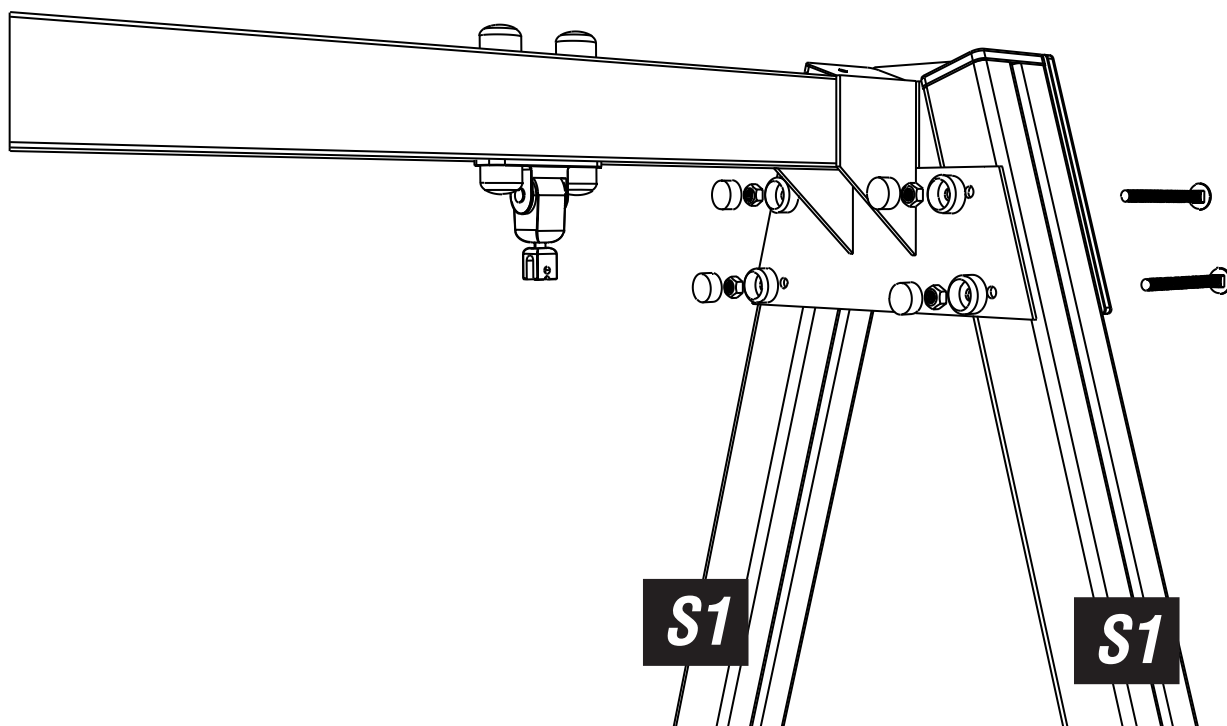

- 2** ATTACH PLAYTEC COVER TO TIMBERS S1
USING M8X80 WOODSCREWS [X4]

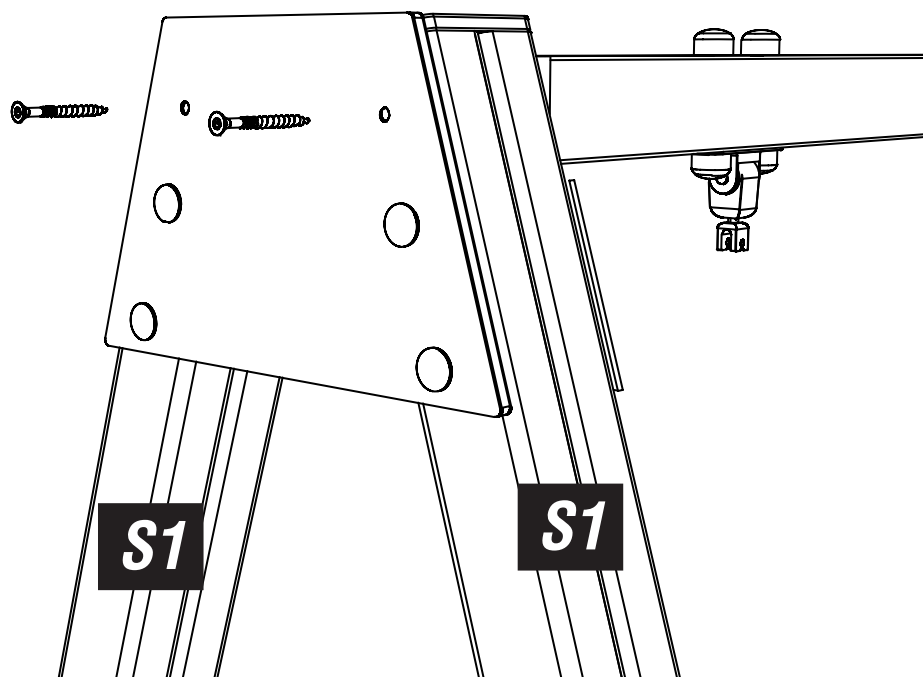

INSTALLATION INSTRUCTIONS

3 INSTALL THE ASSEMBLY FOLLOW FOUNDATION DETAILS

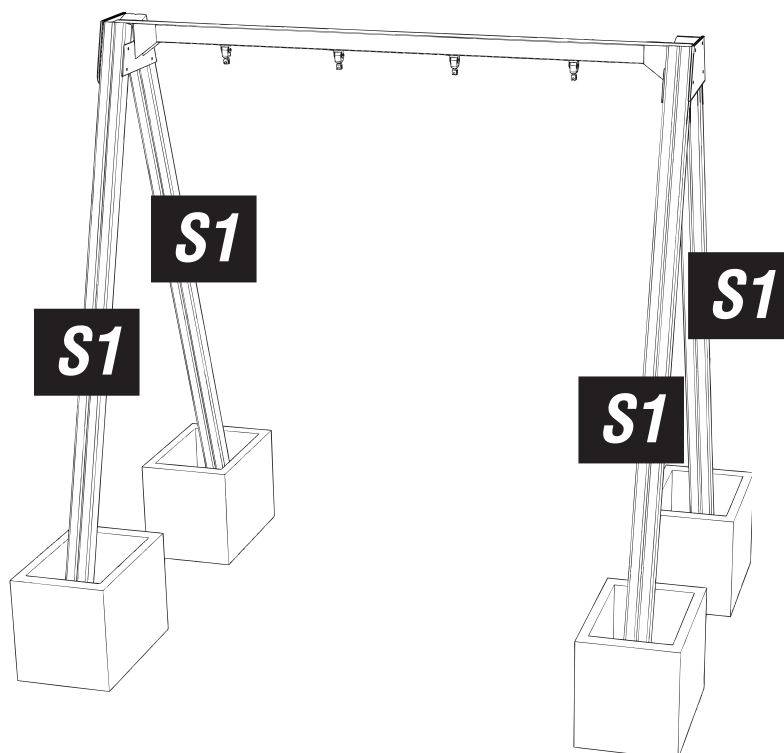

4 ATTACH SEATS TO BEAM FOLLOW DIMENSION DETAILS ON NEXT PAGE

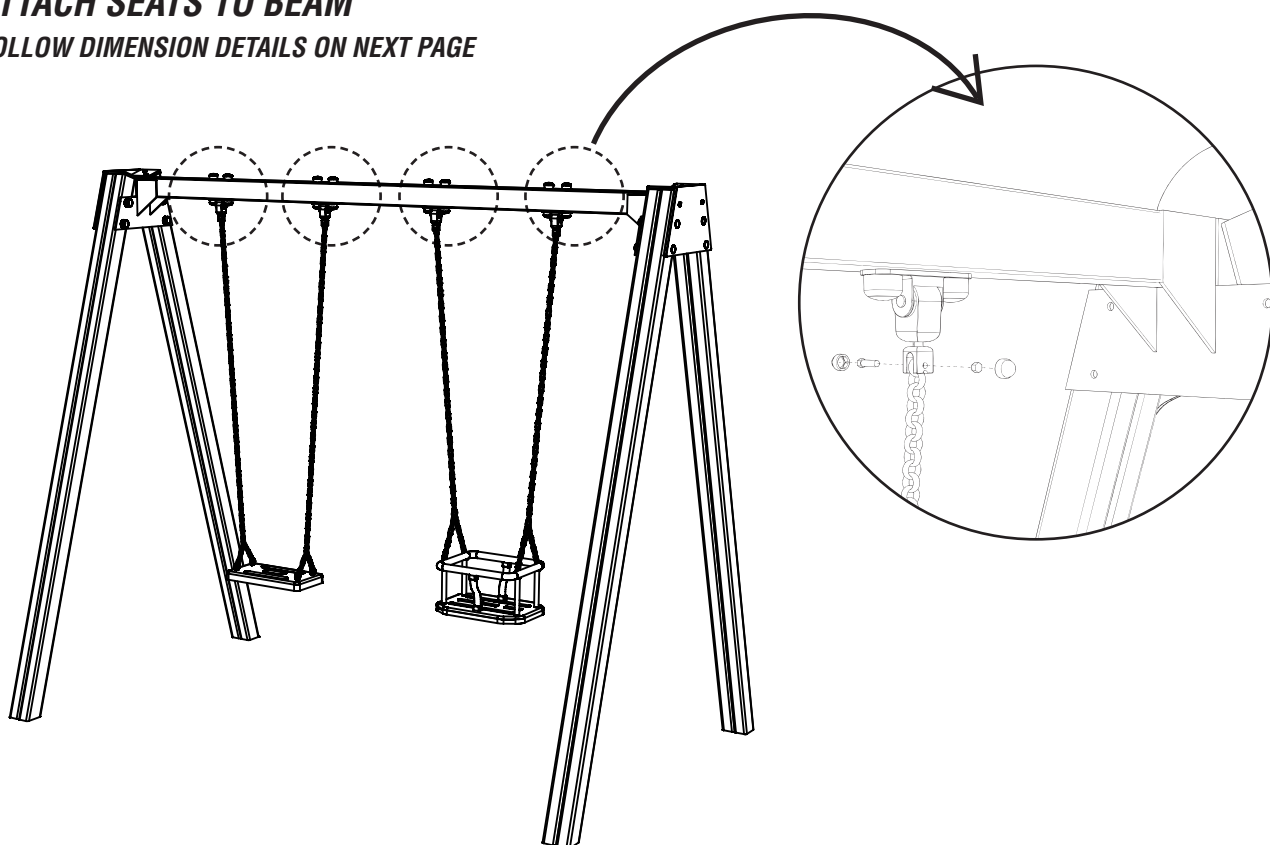

ADDITIONAL DIMENSIONS

