

SWINGING GRIPS

Installation Instructions

**creative
play**

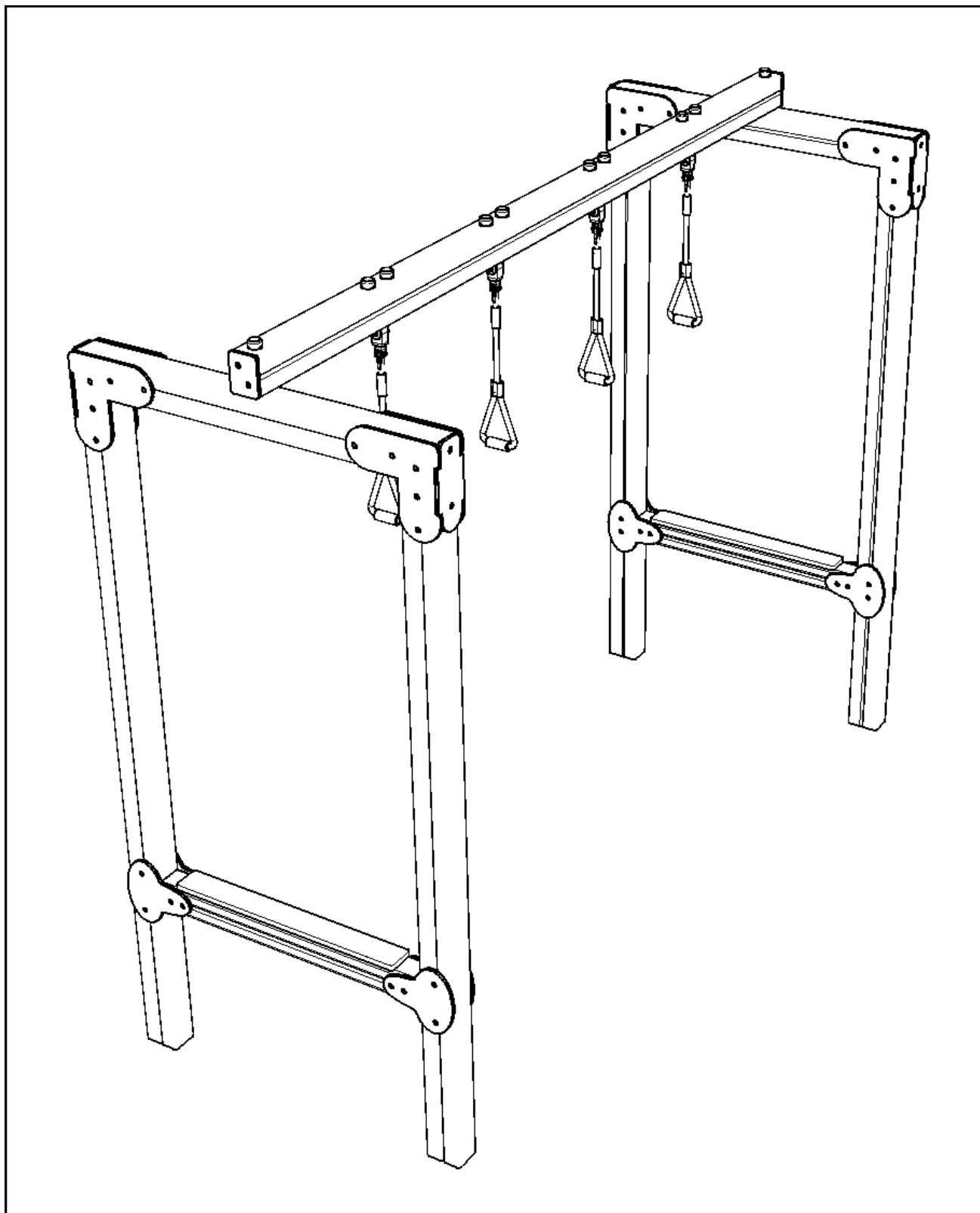

Parts required

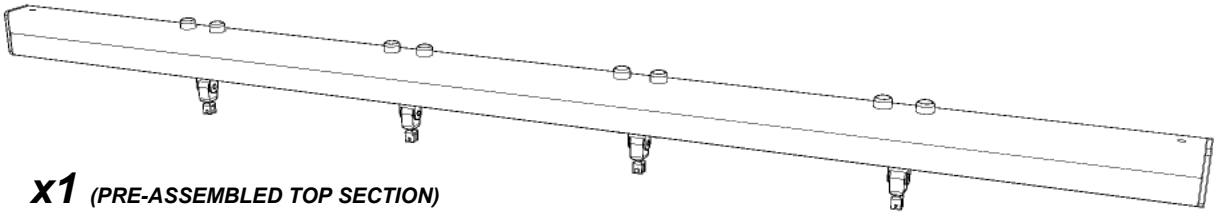

X1 (PRE-ASSEMBLED TOP SECTION)

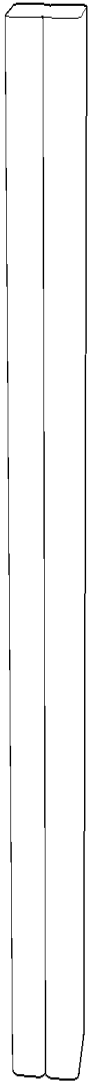

SW1 QTY x 4
(120mm x 90mm)

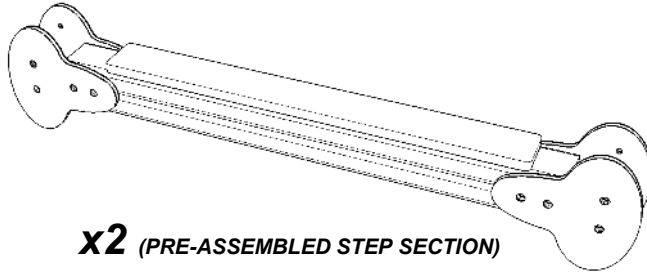

X2 (PRE-ASSEMBLED STEP SECTION)

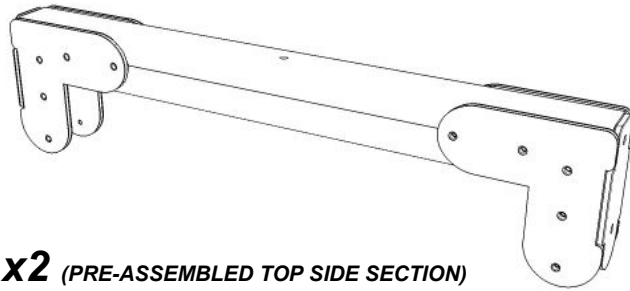

X2 (PRE-ASSEMBLED TOP SIDE SECTION)



X4 (GRIPS)



X2 (M12 x 260
square cup hex bolt)



X36 (FM80 'BRASS SCREW')



X2 (end caps)

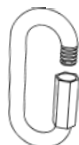

X4 (QUICKLINK)



x2 (M12 NYLOC)

TOOLS required



Foundation details

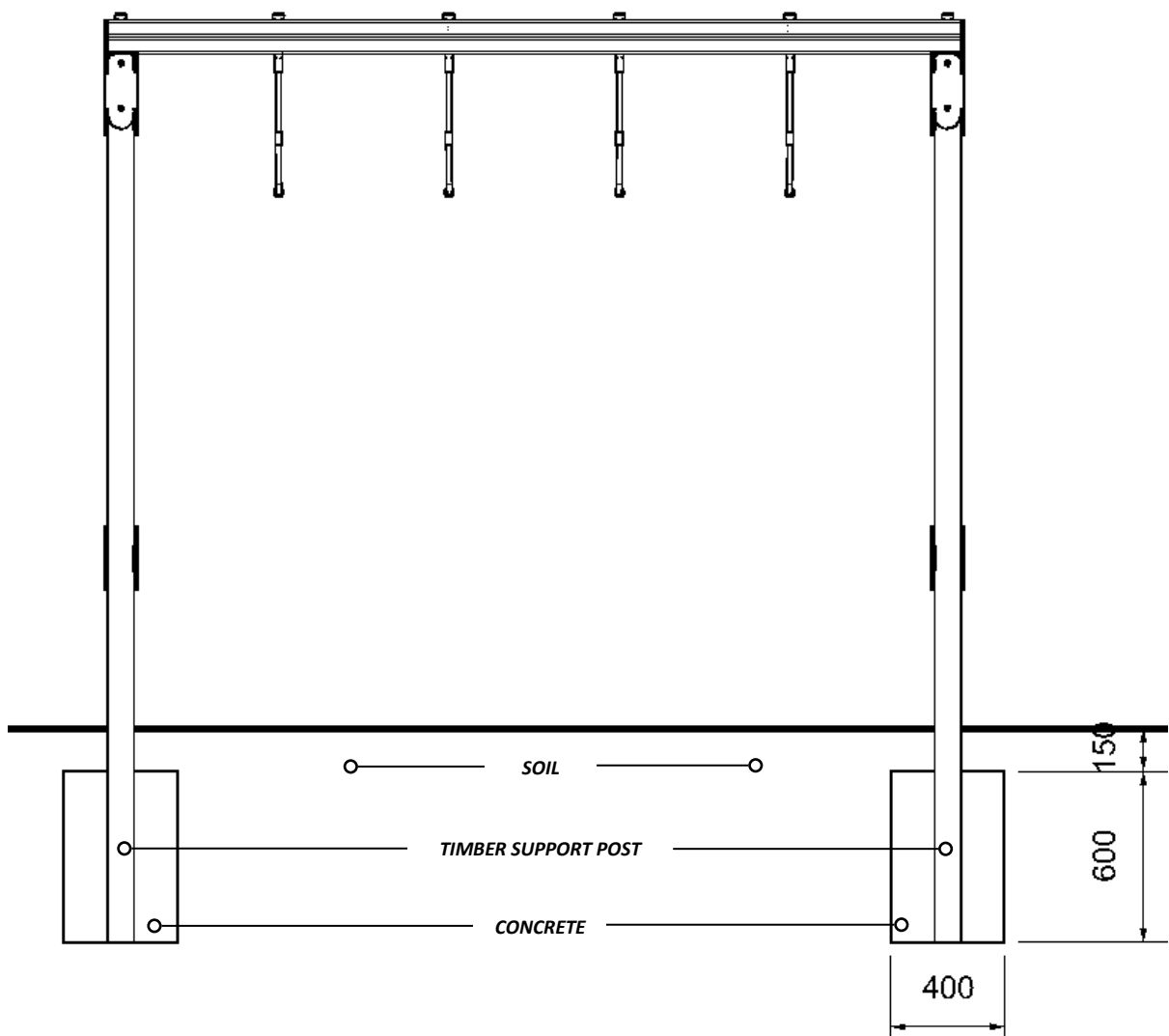
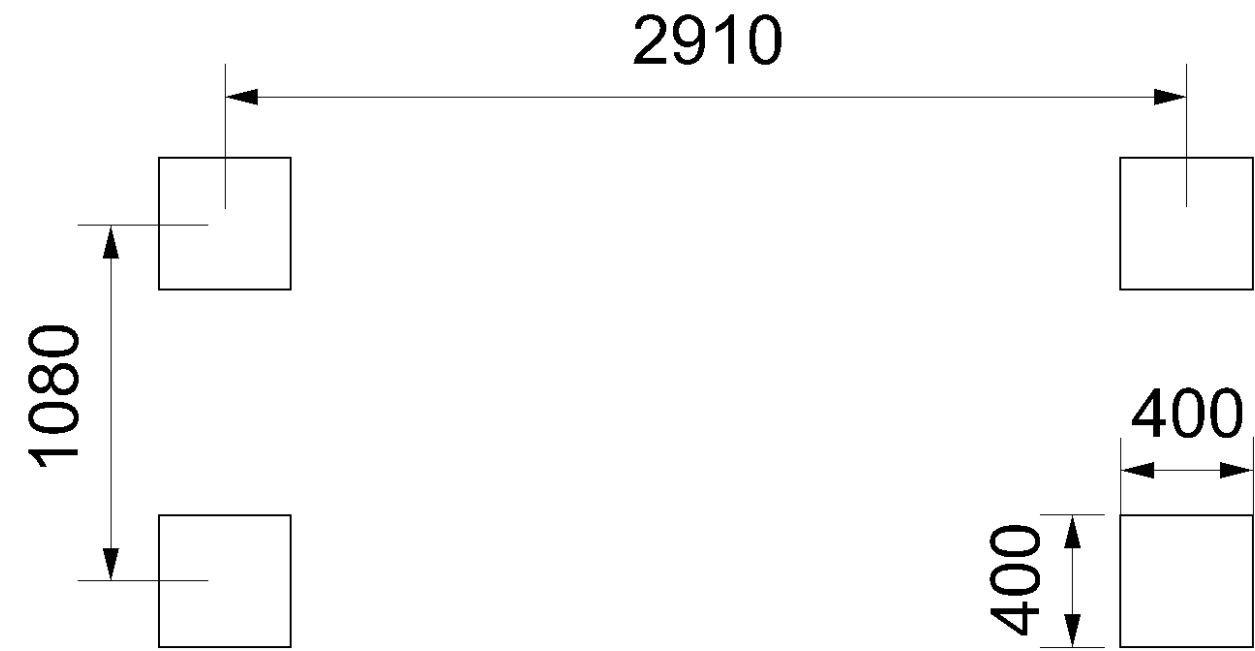

Surfacing details

----- = MINIMUM SPACE
————— = SURFACING AREA

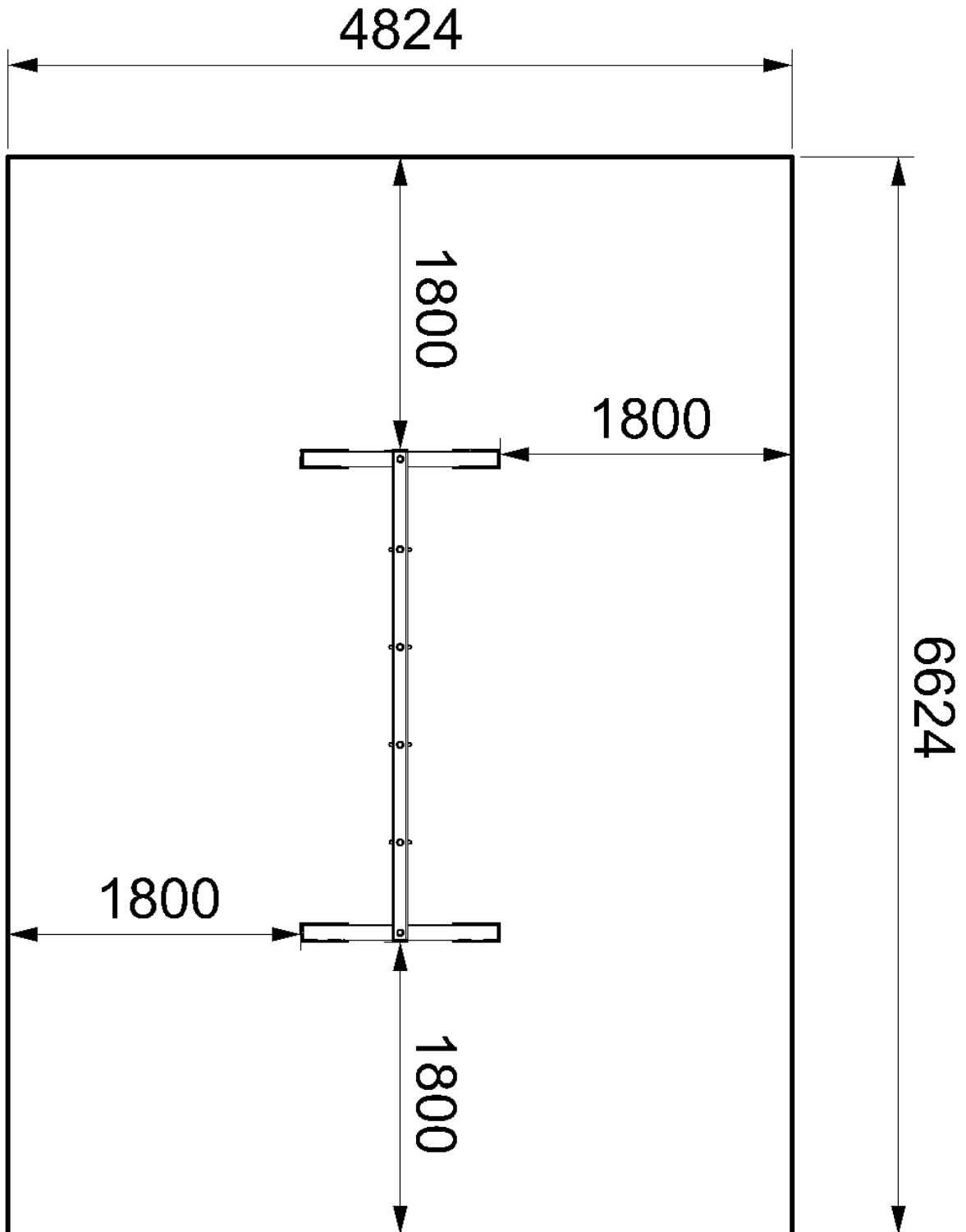

Assembly instructions

1

Install the timbers (SW1)

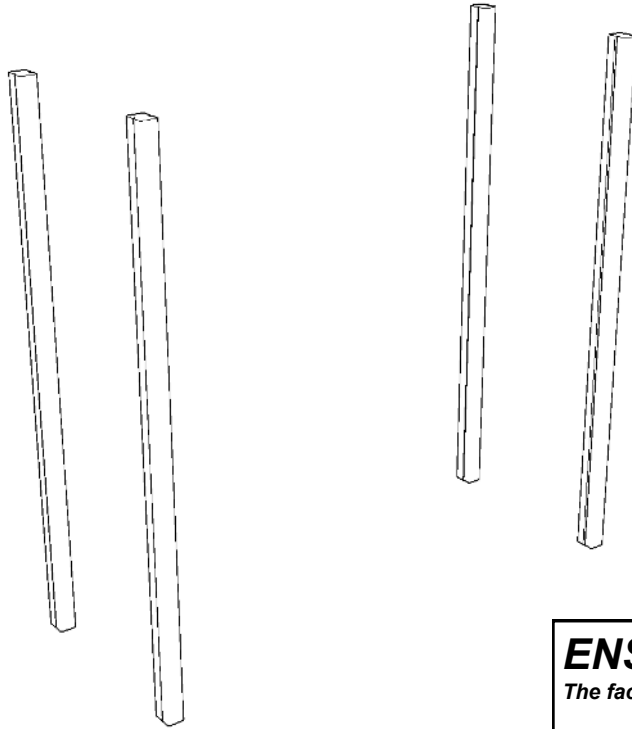

ENSURE:

The faces are in the correct direction

2

Attach the **PRE-ASSEMBLED STEP SECTIONS**

Using FM80 BRASS SCREWS

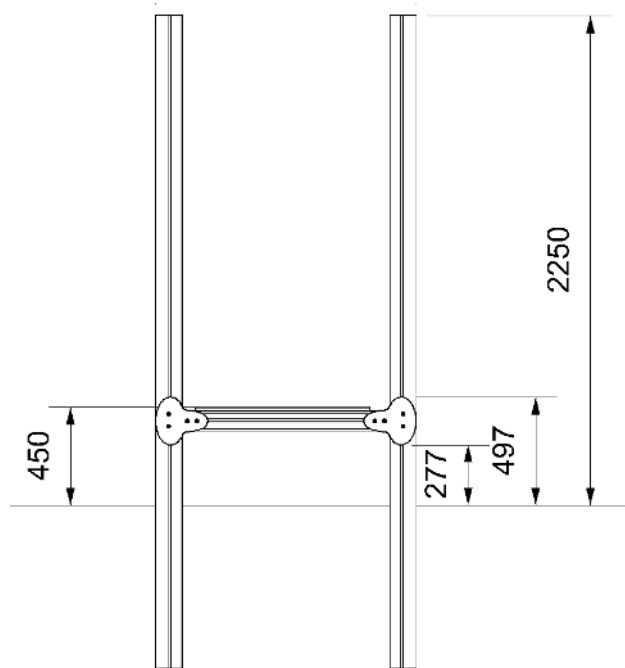
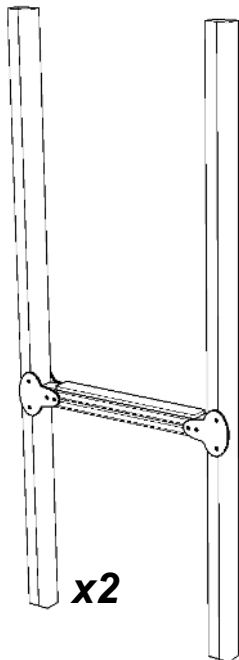

Assembly instructions

3

Attach the PRE-ASSEMBLED TOP SECTIONS

Using FM80 BRASS CREWS

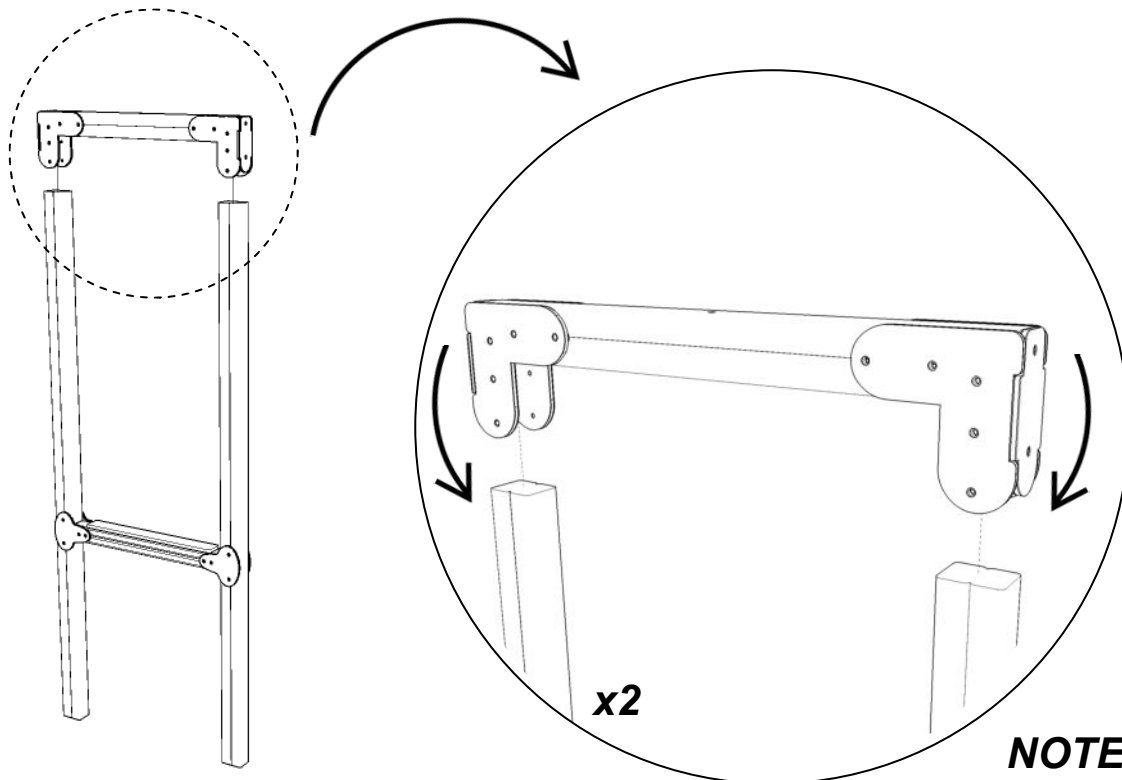

4

Attach the TOP SECTION to the TOP SIDE SECTIONS

using M12 CUP SQUARE BOLTS / NYLOCS / END CAPS

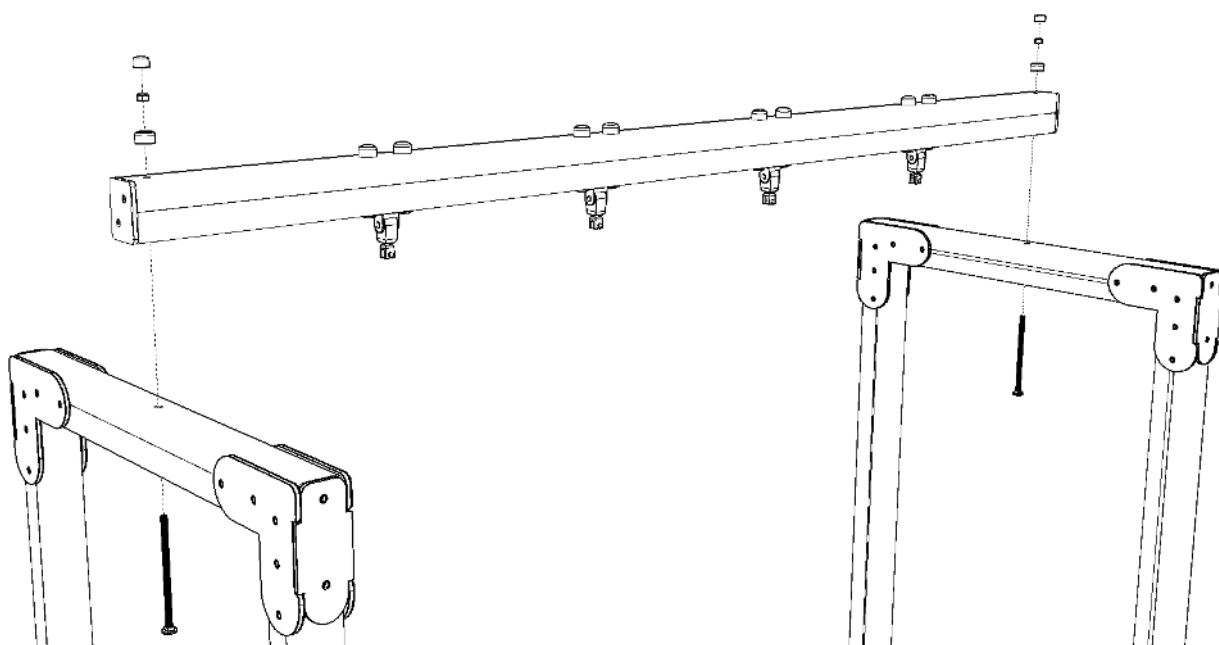

Assembly instructions

5

Attach the TYRE - ROPE to the TOP PIECE

Use **LOCK TIGHT** to ensure the quick link remains **CLOSED**

ENSURE:
COVER THE ENDS WITH BLACK CAPS

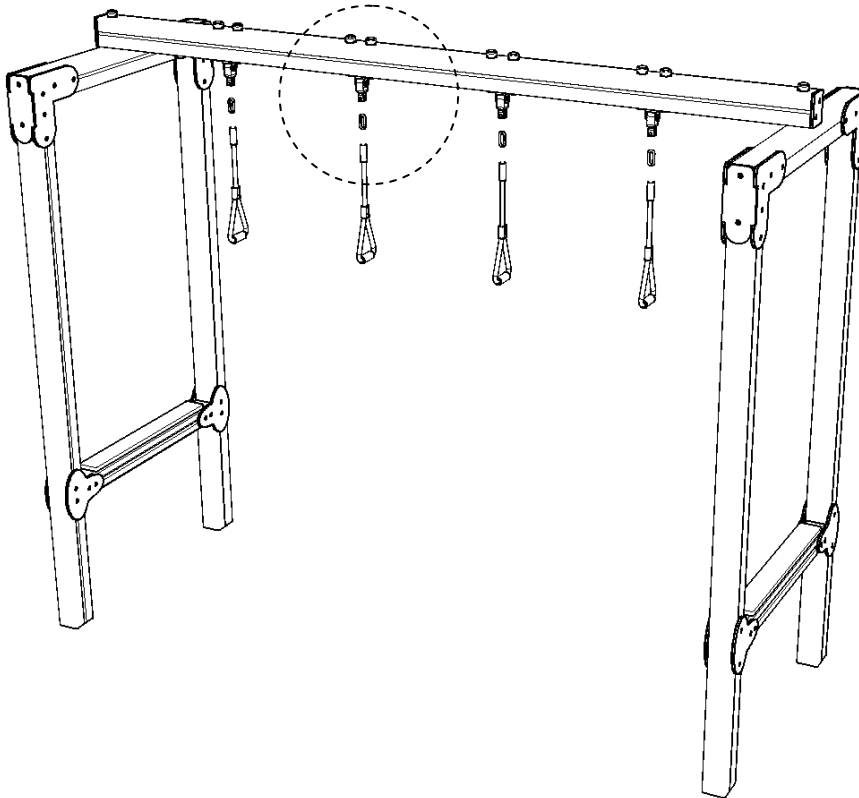
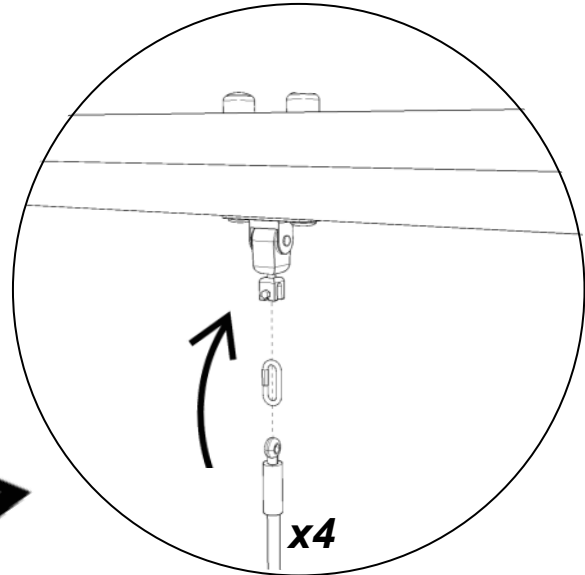

Additional dimensions

