

# CH105 - MOVING BEAM

## Installation Instructions

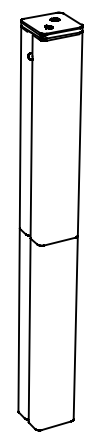
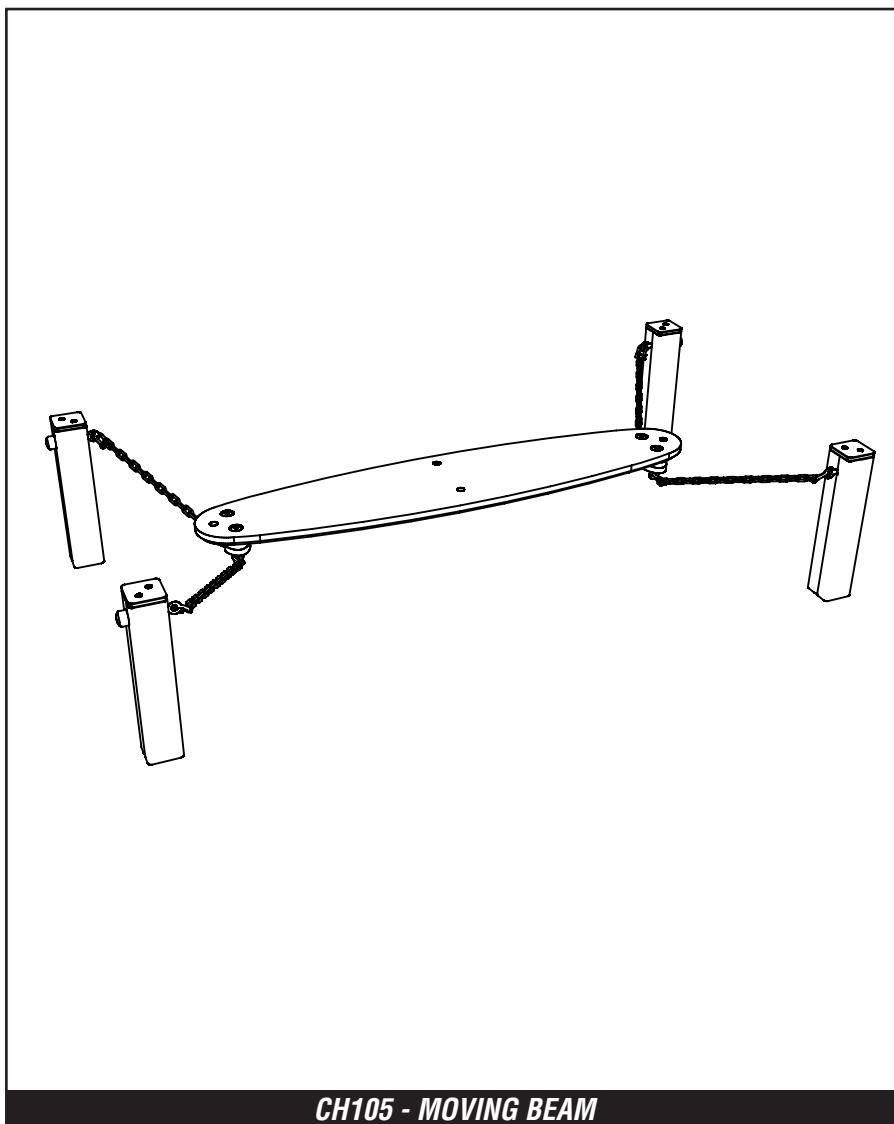

x4

**MB1 (CAPPED) 90MM X 90MM**

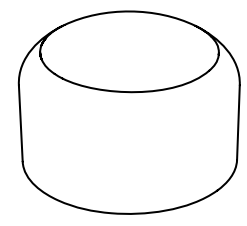

x4

**END CAPS**

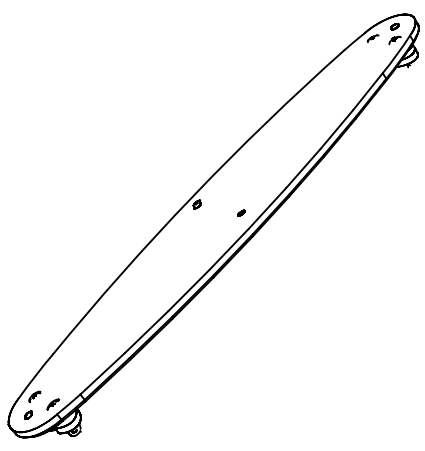

x1

**PRE-ASSEMBLED BEAM**



x4

**EYEBOLT X130mm**

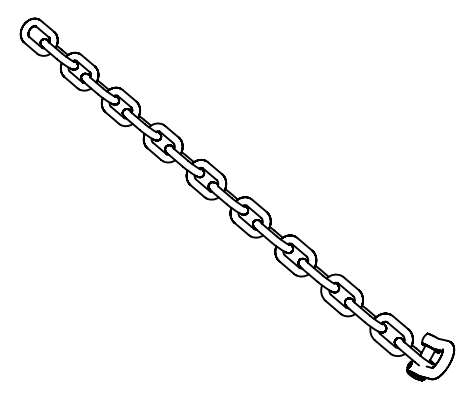

x4

**CHAIN X 530MM (18 LINKS)**

# ***PARTS REQUIRED***

---

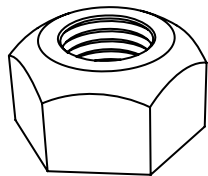

***x4***

***NYLOC (M12)***

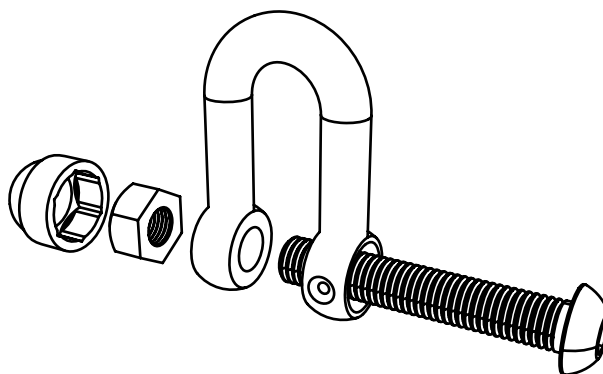

***CONSISTS OF  
SHACKLE / BOLT / NYLOC / CAP***

***x8***

***349.742.D-SHACKLE 'SET' (inc 4 spares)***

# FOUNDATION DETAILS

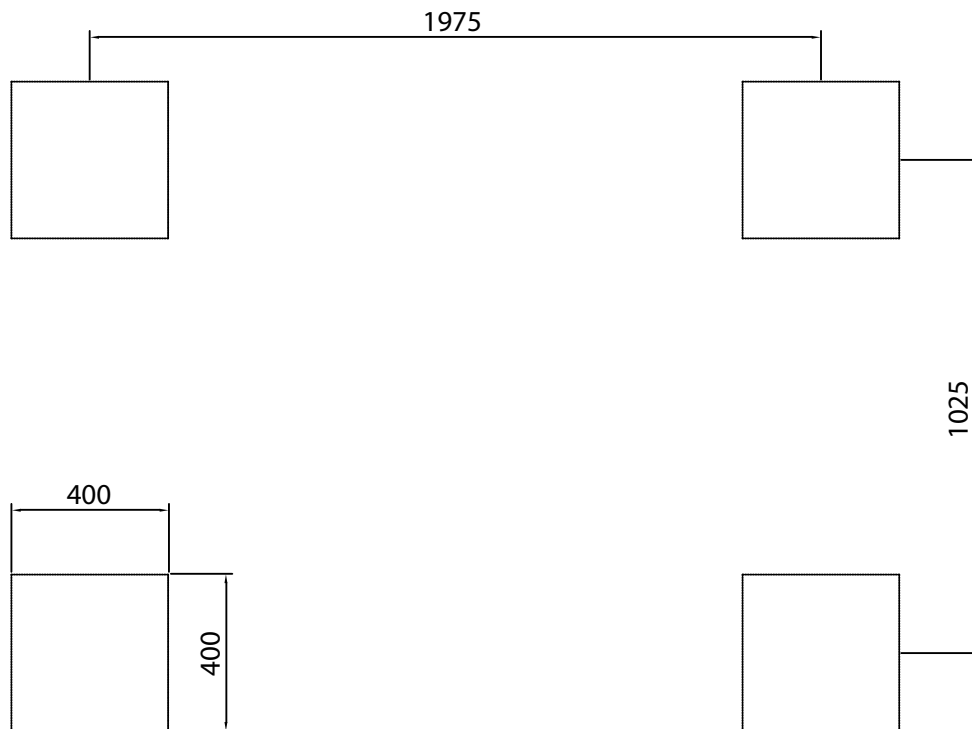
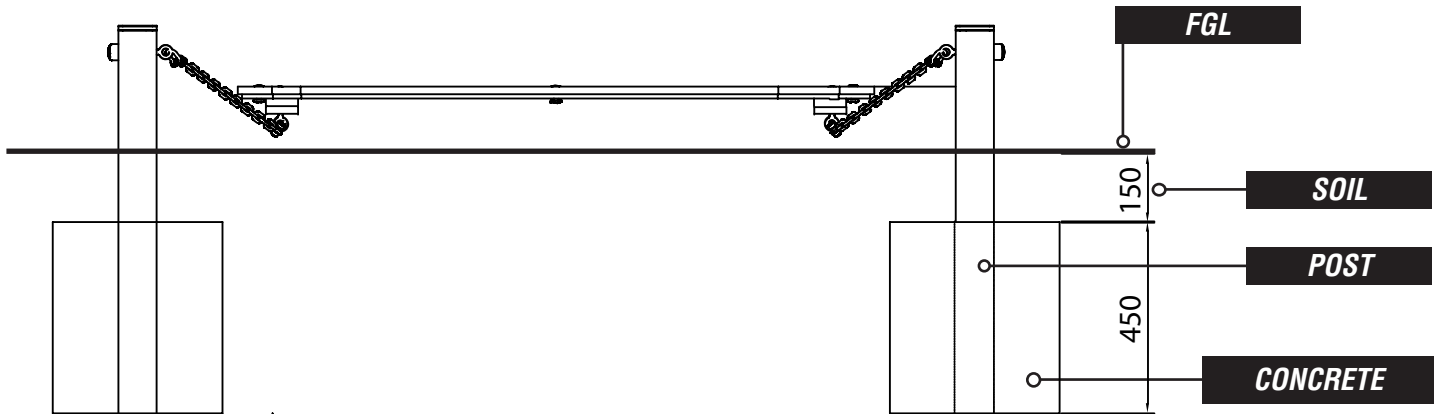

# ***SURFACING DETAILS***

---

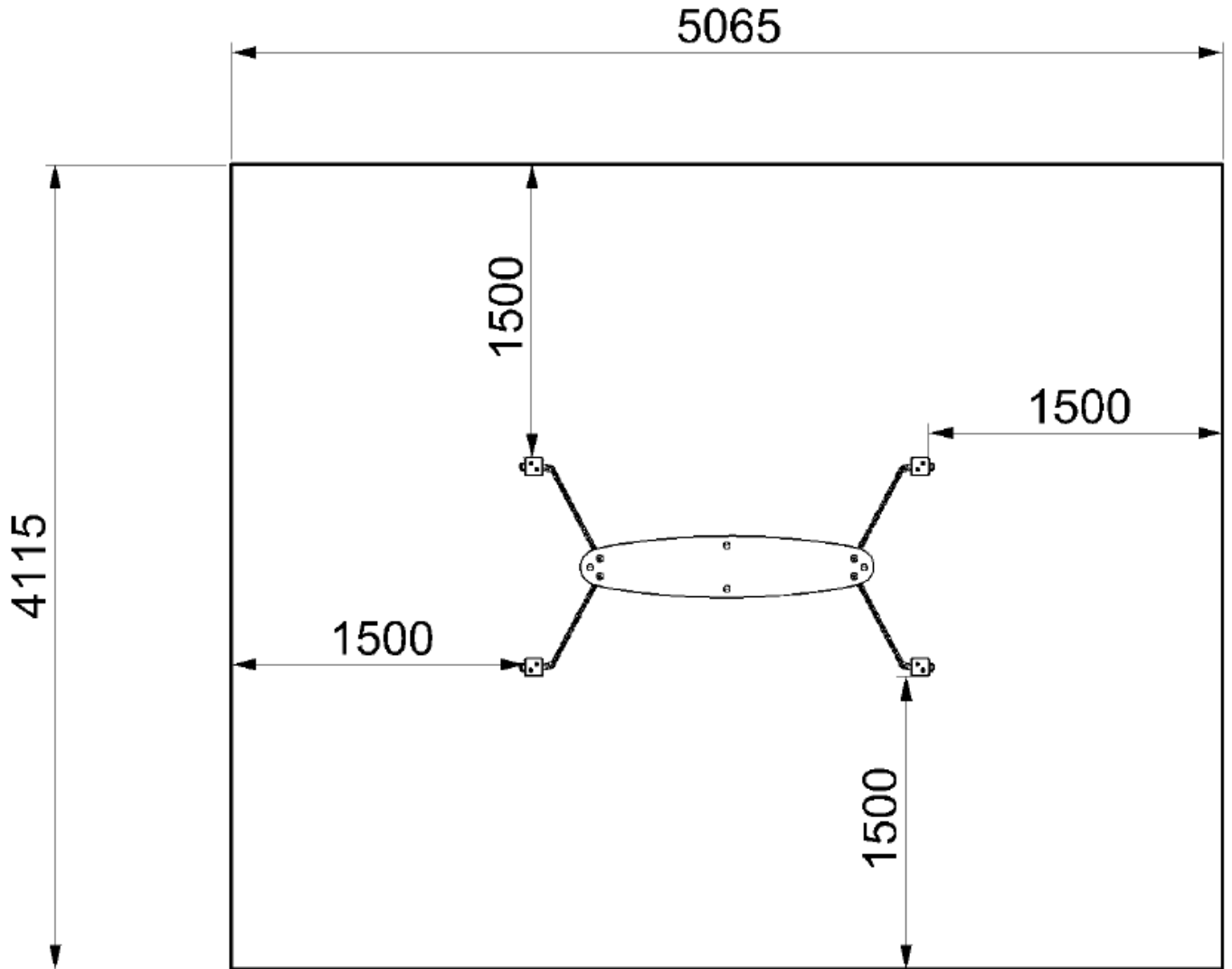

# INSTALLATION INSTRUCTIONS

---

## **1** INSTALL THE TIMBERS MB1 USING - MB1 X4

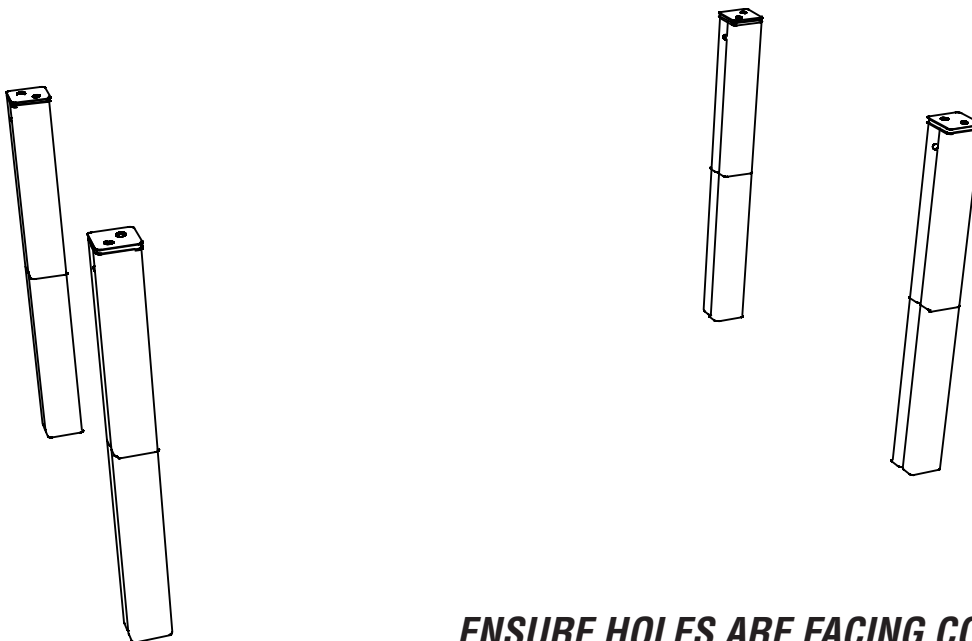

**ENSURE HOLES ARE FACING CORRECTLY**

## **2** ATTATCH EYEBOLT X130mm TO THE TIMBER USING EYBOLT X130MM X4 / NYLOC X4 / ENDCAPS X4

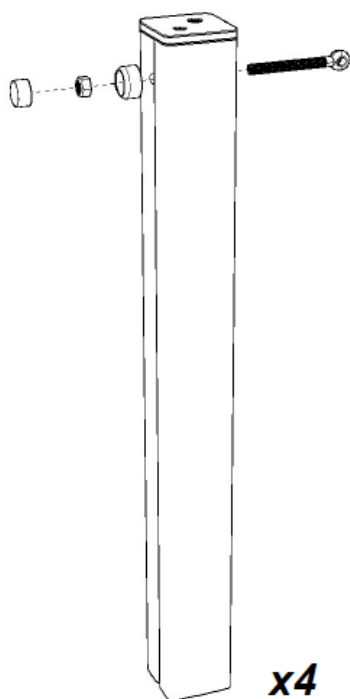

**REPEAT FOR REMAINING POSTS**

# INSTALLATION INSTRUCTIONS

---

**3**

**ATTATCH THE CHAIN TO THE EYBOLT USING THE D-SHACKLE**  
**USING CHAIN X4 / D-SHACKLE X4**

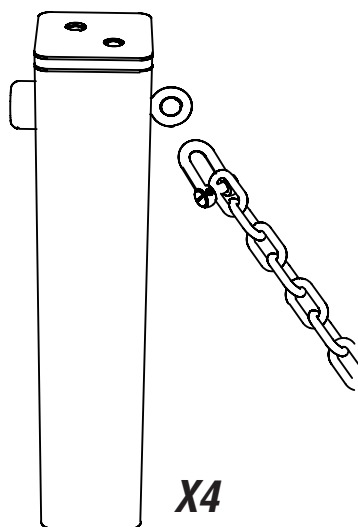

**4**

**ATTATCH THE CHAIN TO THE MOVING BEAM**  
**USING CHAIN X4 / D-SHACKLE X4 / M12 SOCKET X4**

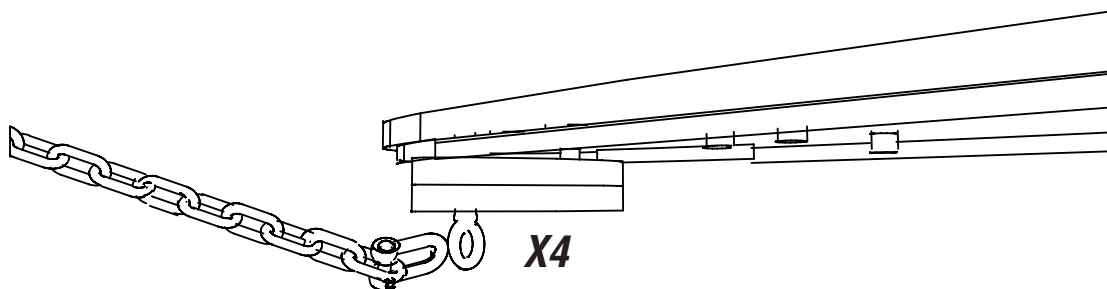

# ***ADDITIONAL DIMENSIONS***

---

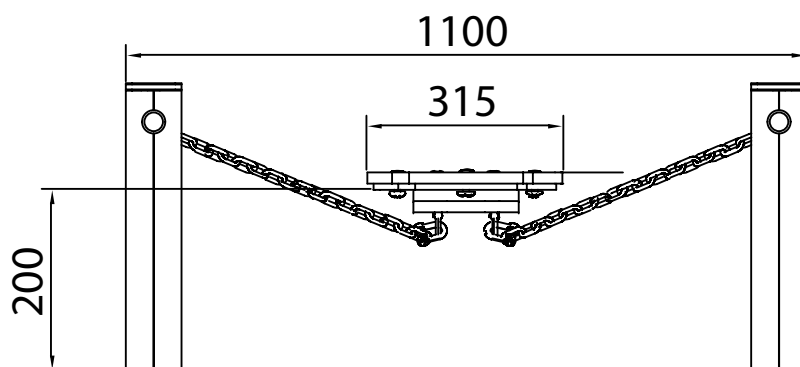
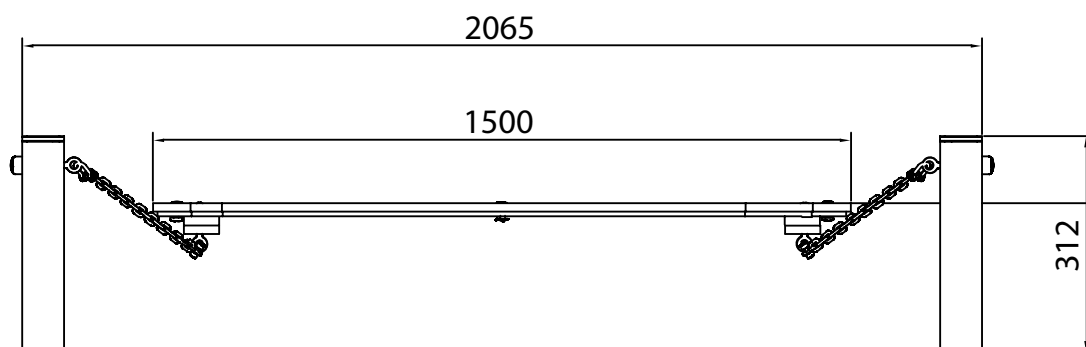

***ENSURE DISTANCE BETWEEN FLOOR AND BEAM MINIMUM OF 200mm.***