

CH108-R - BALANCE BEAM
Installation Instructions

**creative
play**

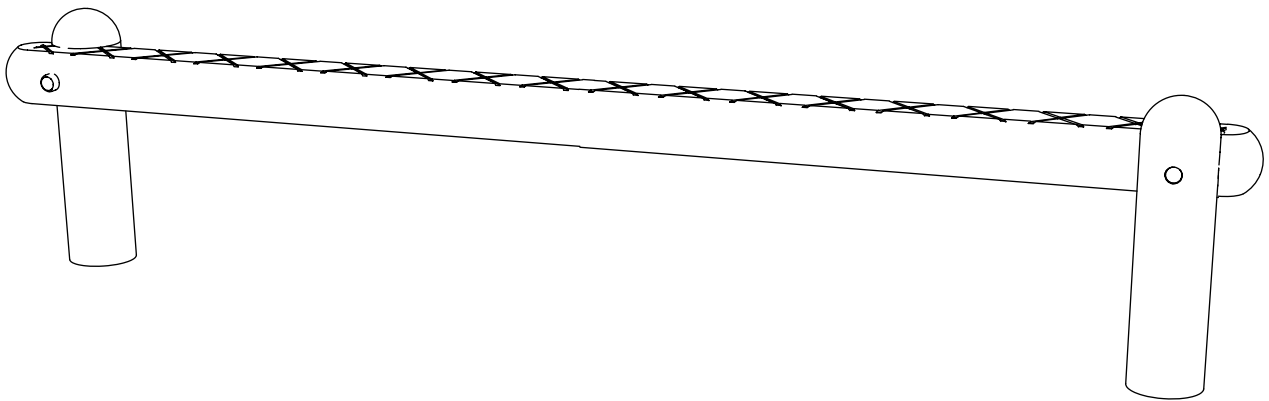

PARTS REQUIRED



R-108A TIMBER



CH108B TIMBER [X2]

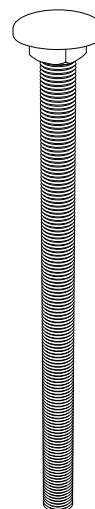

M12 X 240 BOLT [X2]

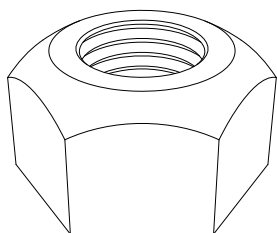

M12 NYLOC [X2]

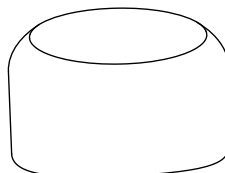
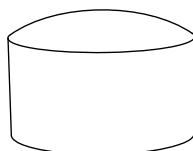

COVERED ENDS R-60 [X2]

TOOLS REQUIRED

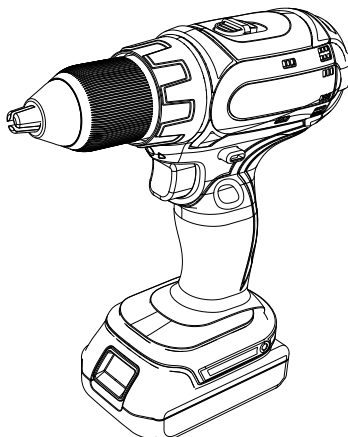
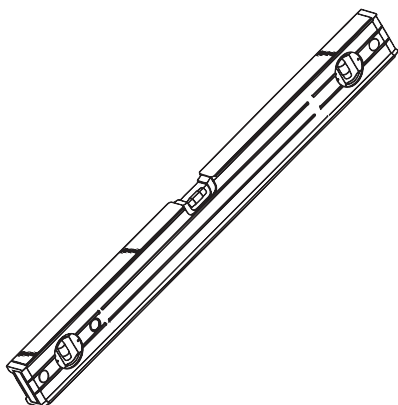

FOUNDATION DETAIL

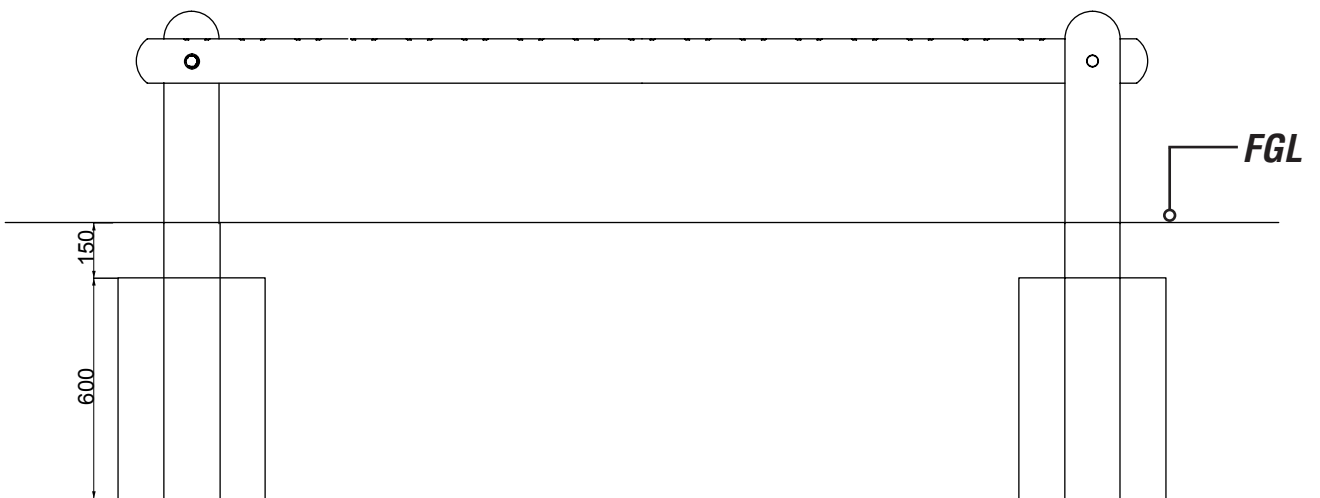
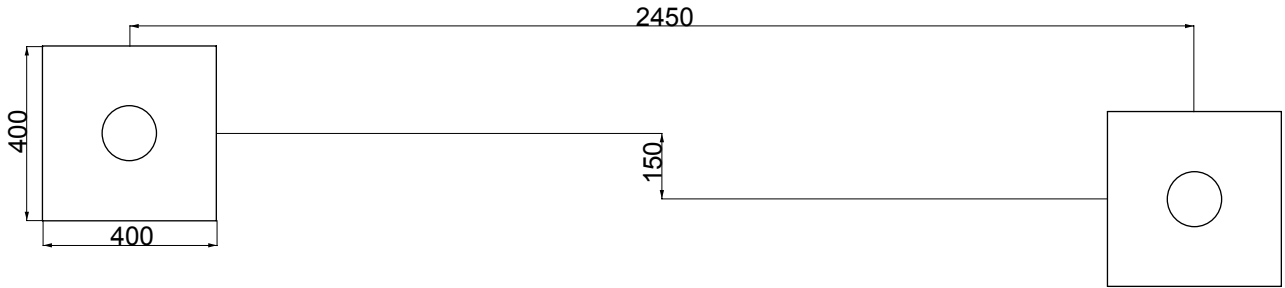

INSTALLATION INSTRUCTIONS

- 1** ATTACH ALL R-108A AND R-108B TIMBERS TOGETHER
USING M12X240 BOLTS, M12 NYLOCS AND ROUND COVERED ENDS

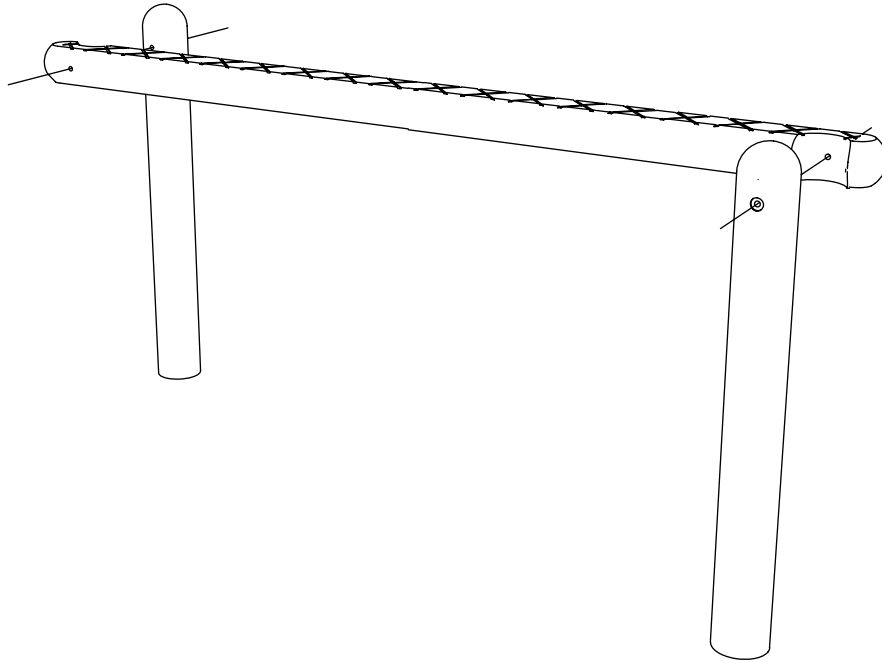

- 2** INSTALL BALANCE BEAM IN THE GROUND

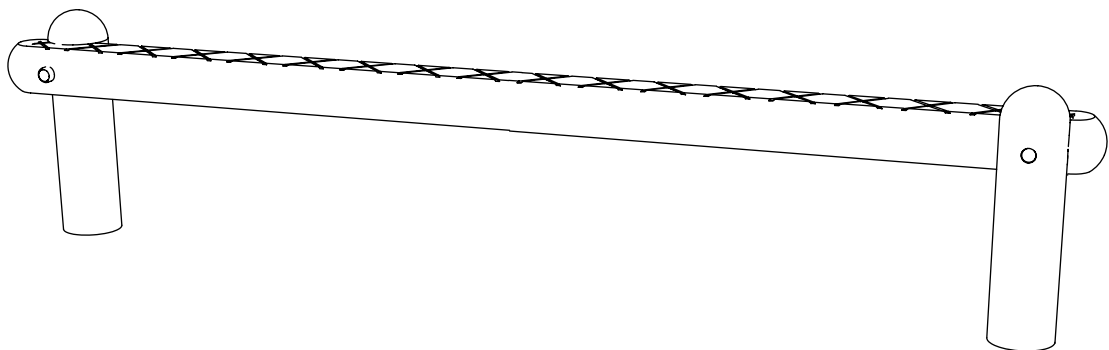

ADDITIONAL MEASUREMENTS

