

GYM203L - PRESS UP BARS - ADULT (LOW)
Installation Instructions

**creative
play**

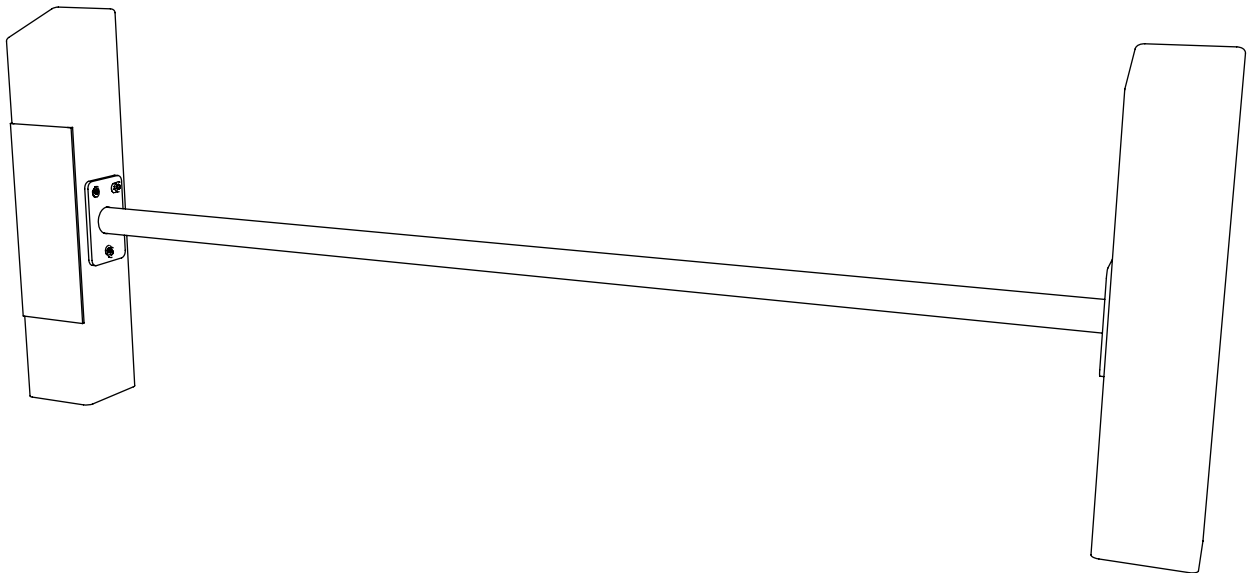

PARTS REQUIRED

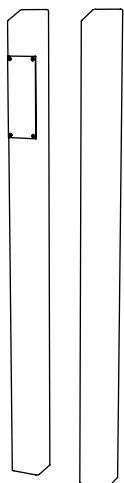

GM203L-A & GM203L-B



STANDARD BAR - 1480mm [X1]

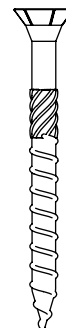

M8 X 80 SCREWS [X6]

TOOLS REQUIRED

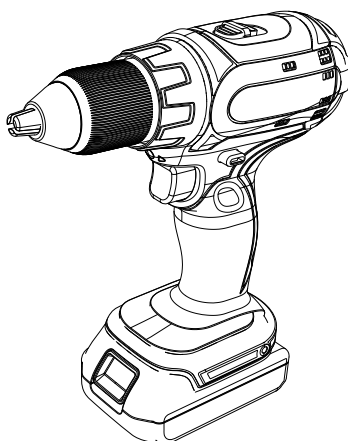
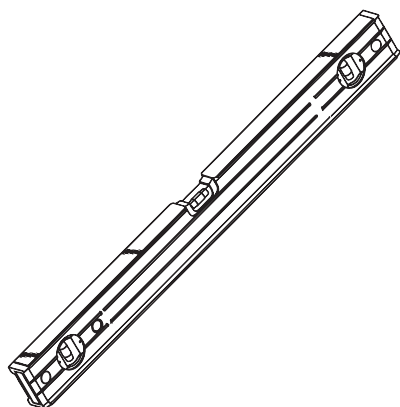

FOUNDATION DETAIL

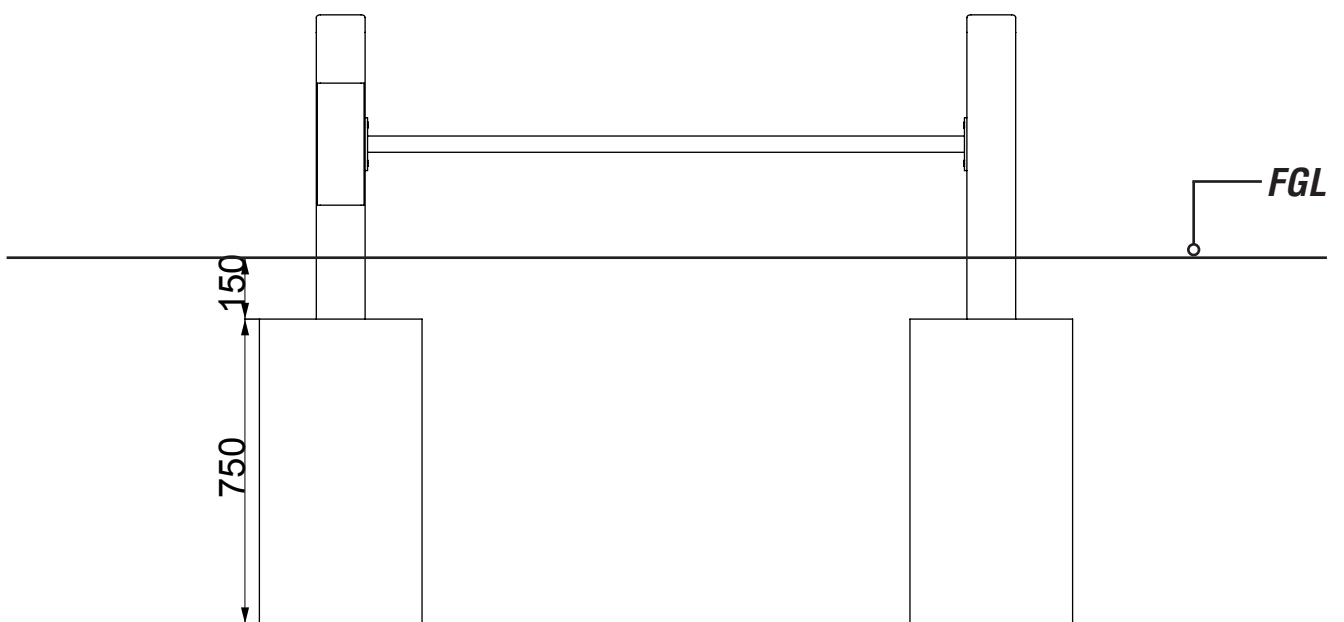
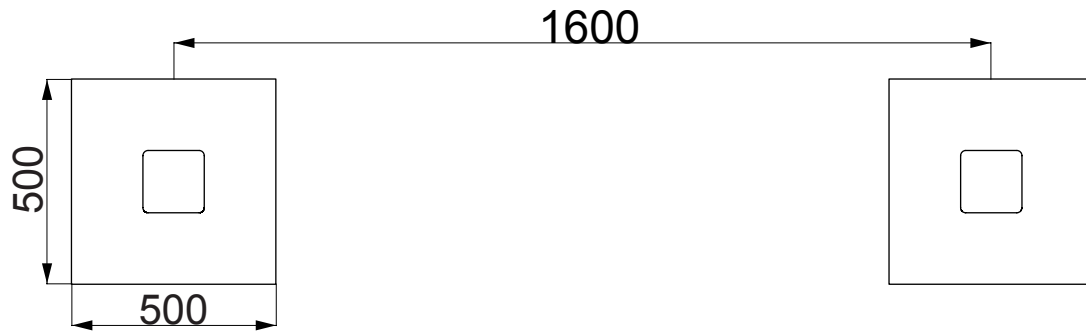

SURFACING - OVERALL AREA

----- = EN16630 STANDARD

————— = EN11-76/77 STANDARD

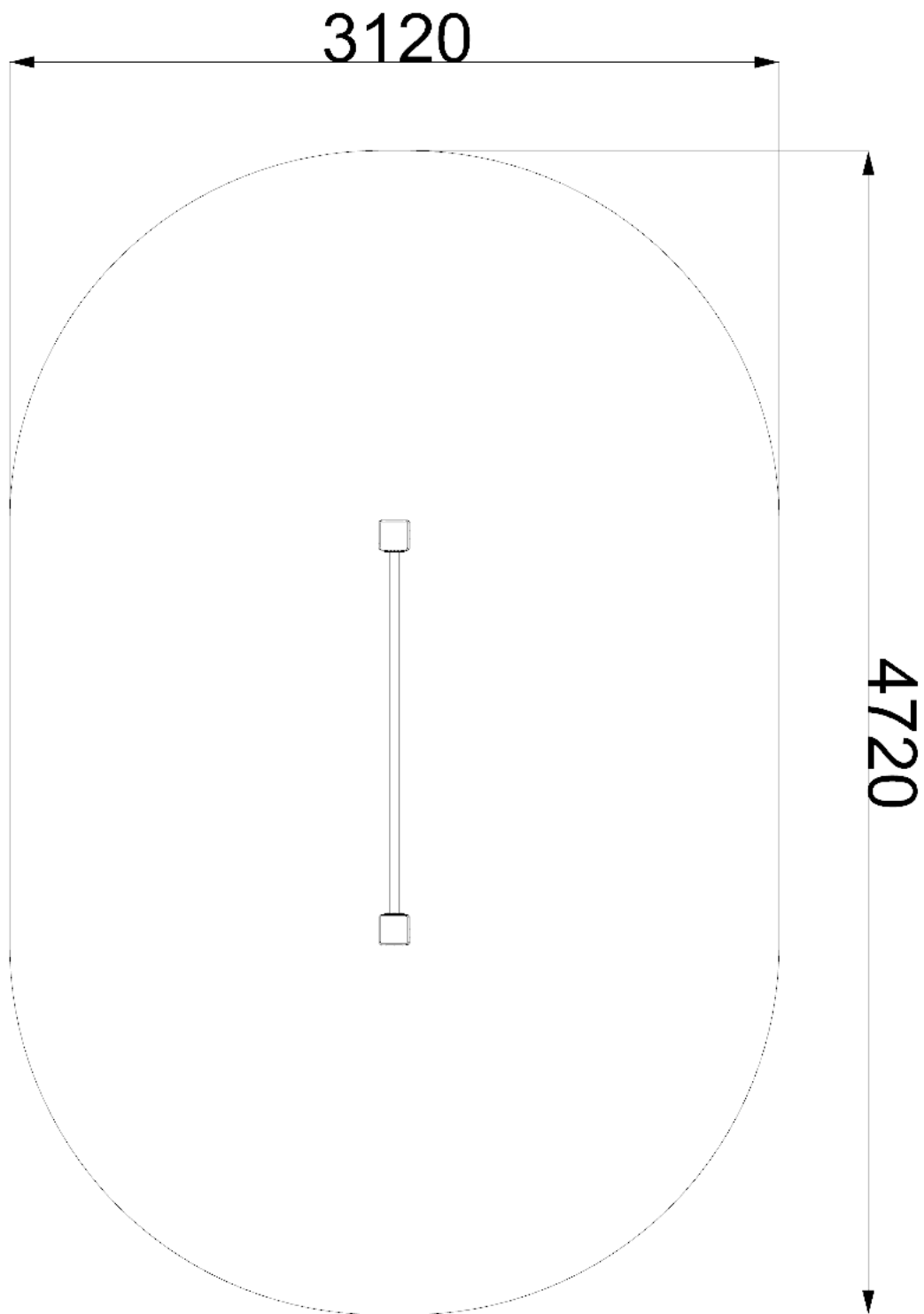

INSTALLATION INSTRUCTIONS

1

ATTACH STANDARD BAR TO GM203L-A AND GM203L-B TIMBERS
USING M8X80 SCREWS

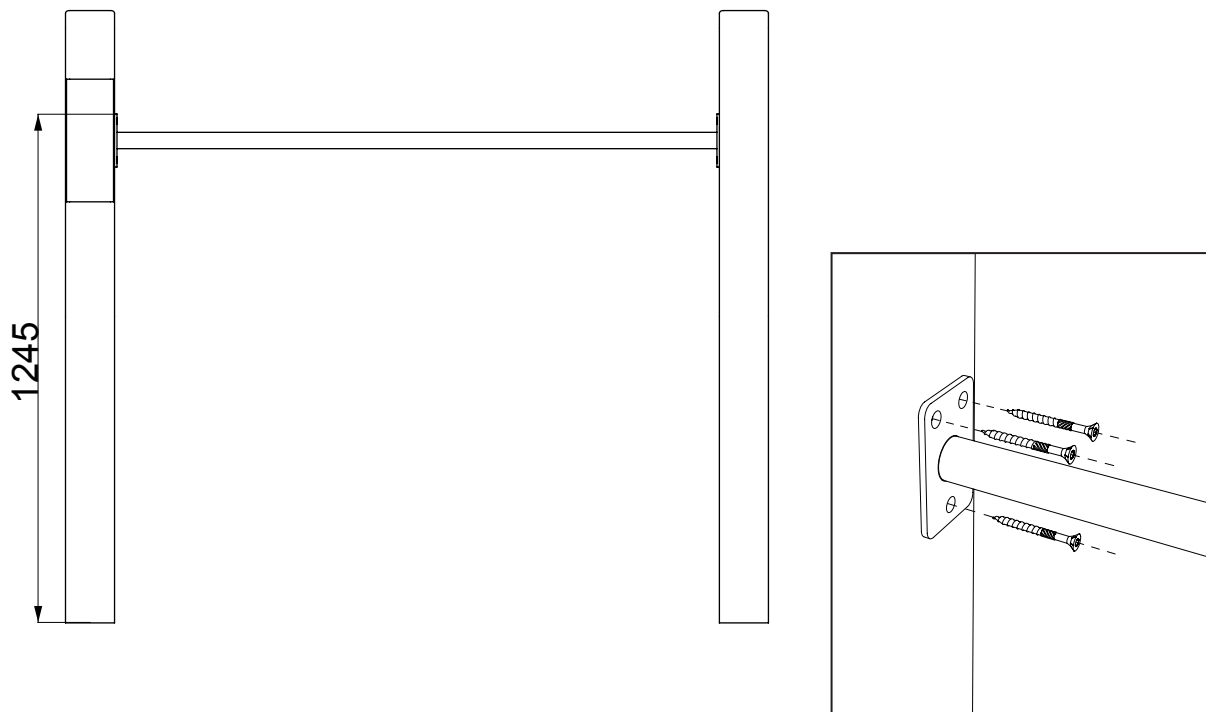

2

INSTALL GYM203 INTO THE GROUND

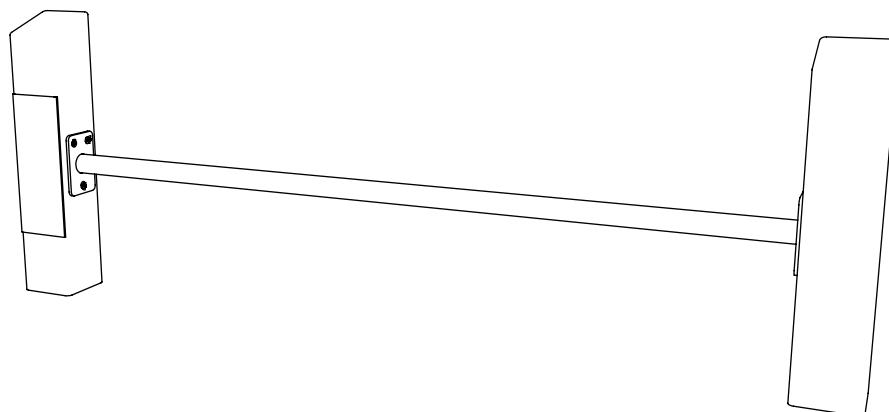

ADDITIONAL MEASUREMENTS

