

BALANCE BEAM

Installation Instructions

**creative
play**

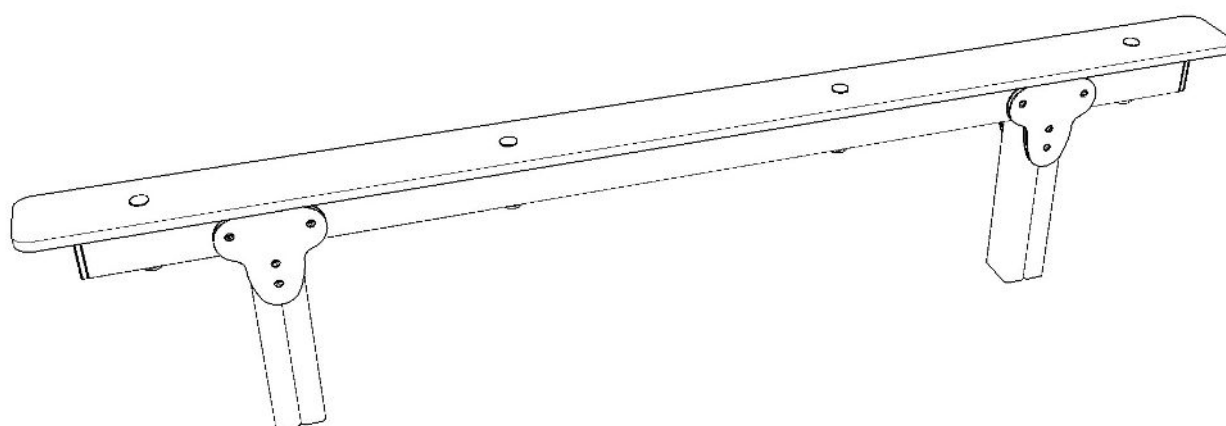

Parts required

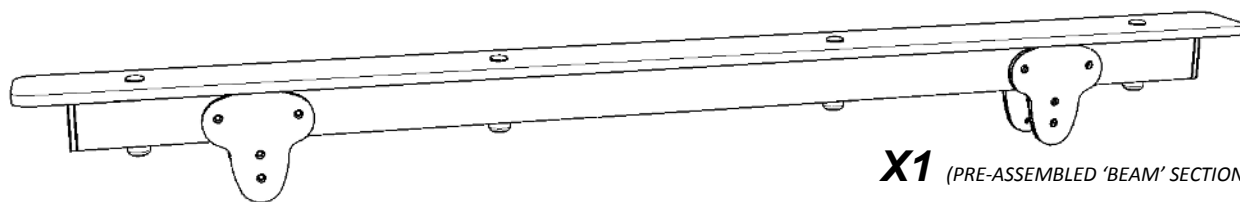

X1 (PRE-ASSEMBLED 'BEAM' SECTION)



BB2 QTY x 2
(90mm x 90mm)



x8 (FM80 'BRASS SCREW')

TOOLS required



Foundation details

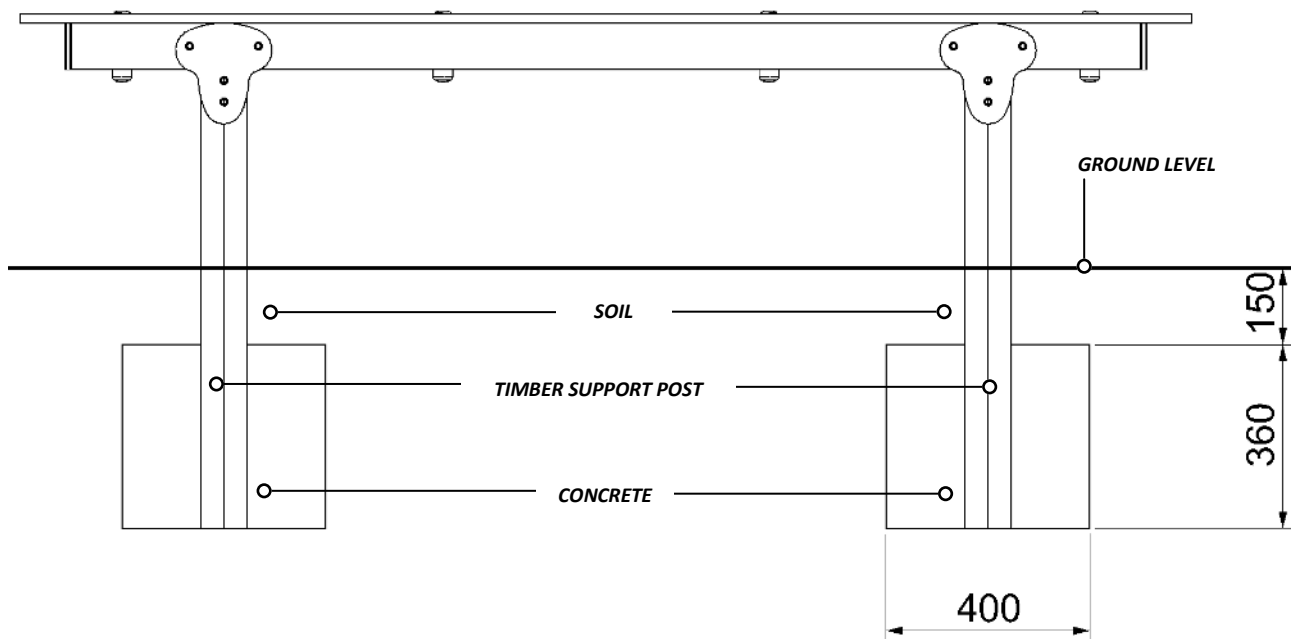
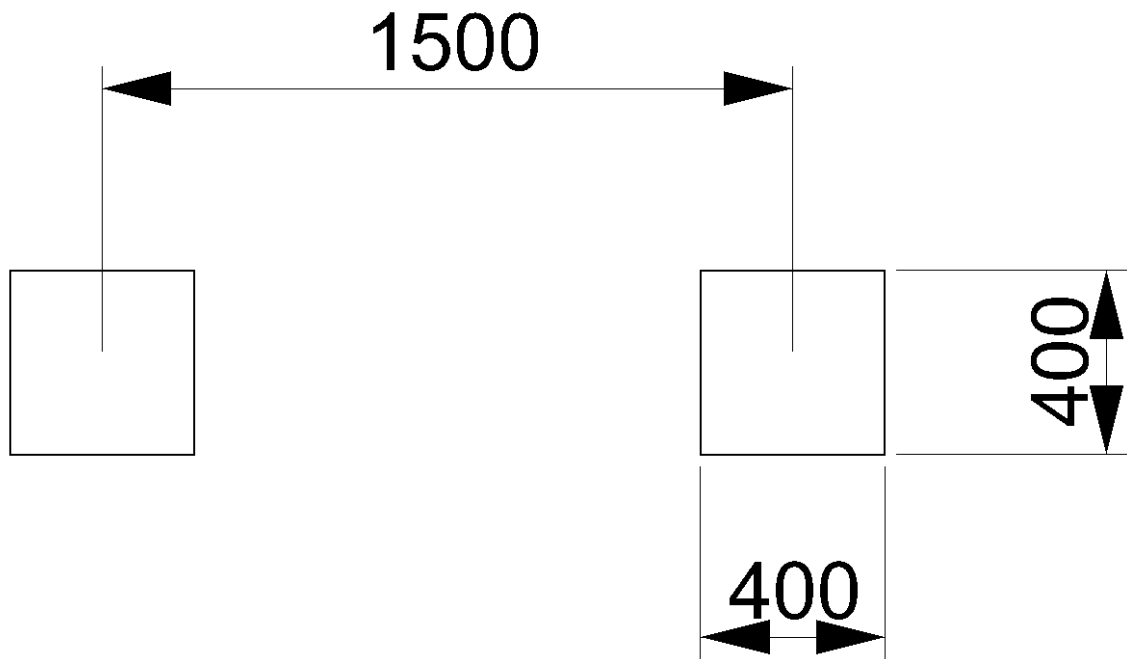

Surfacing details

- - - - - = MINIMUM SPACE
———— = SURFACING AREA

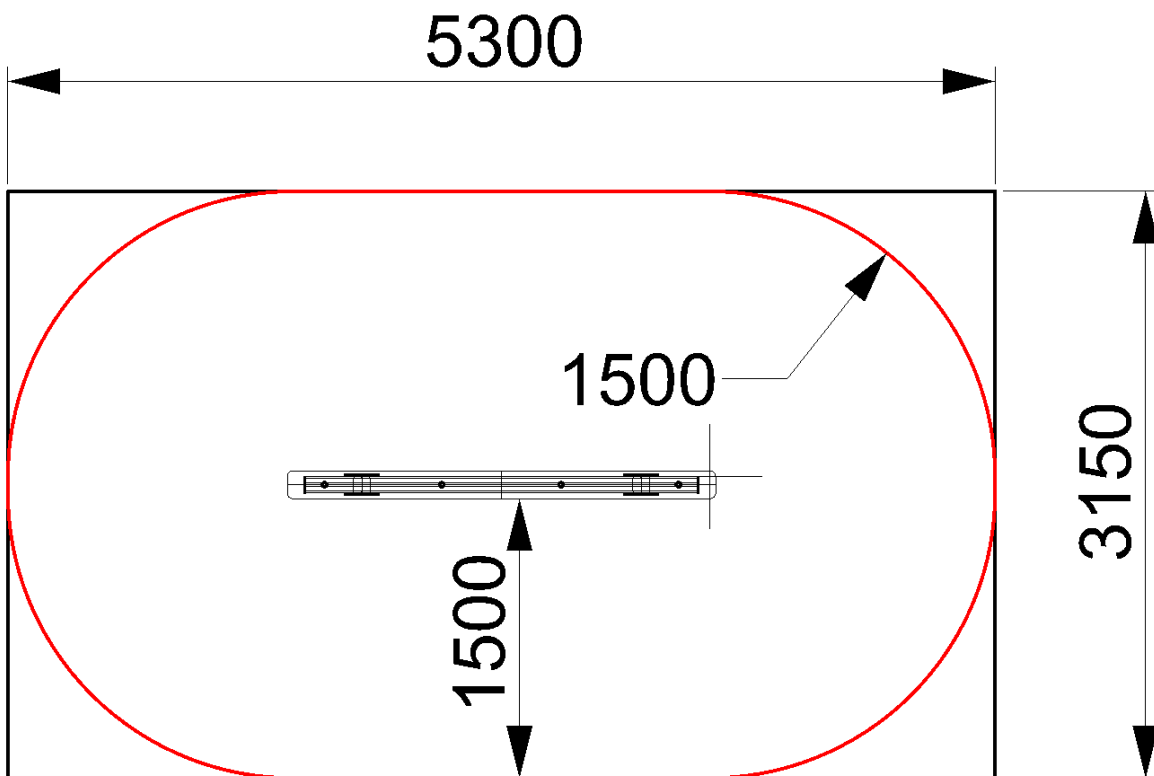

Assembly instructions

1

Attach the preassembled BEAM to the Timbers (BB2)

Using FM80 BRASS CREWS—ATTACH BEFORE LAYING CONCRETE FOUNDATIONS

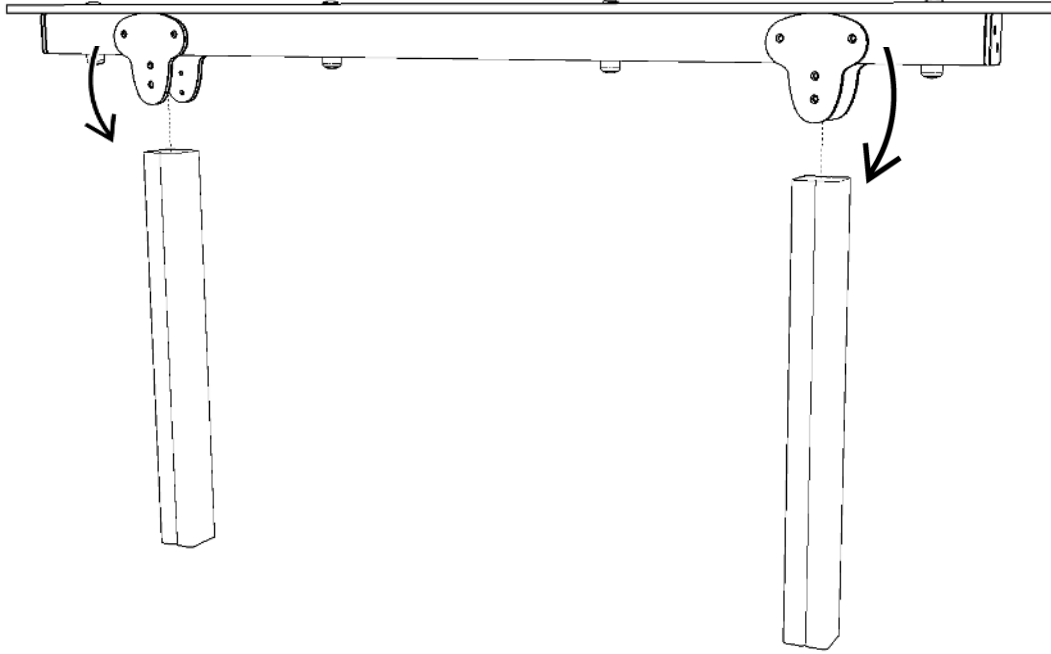

2

LAY CONCRETE FOUNDATIONS

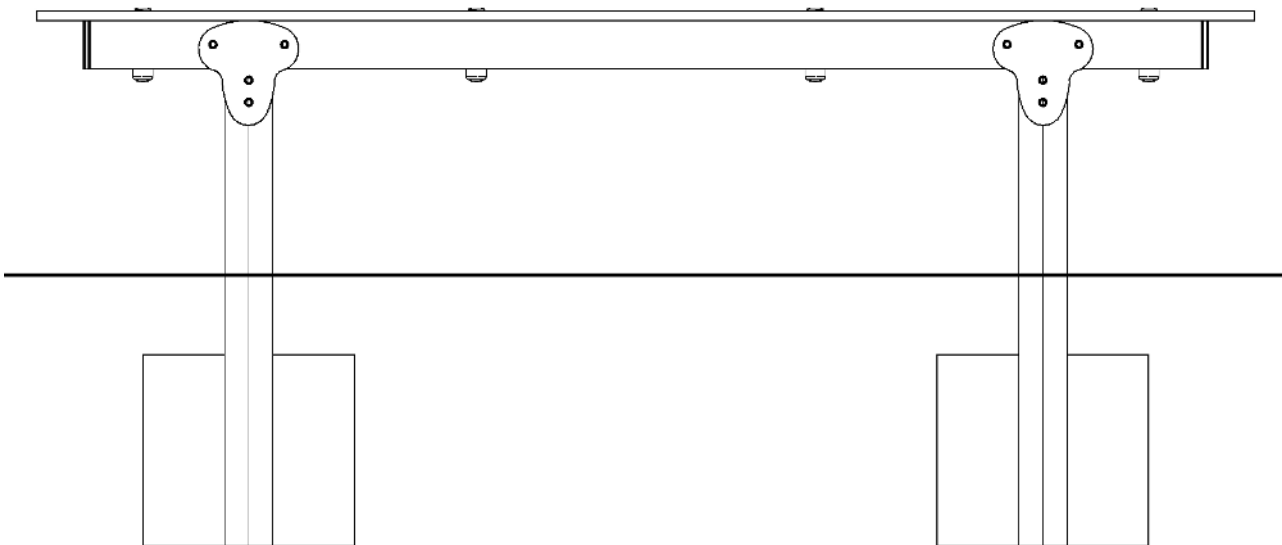

Additional dimensions

