

SR105 - AEROPLANE SPRING RIDER (DOUBLE) Installation Instructions

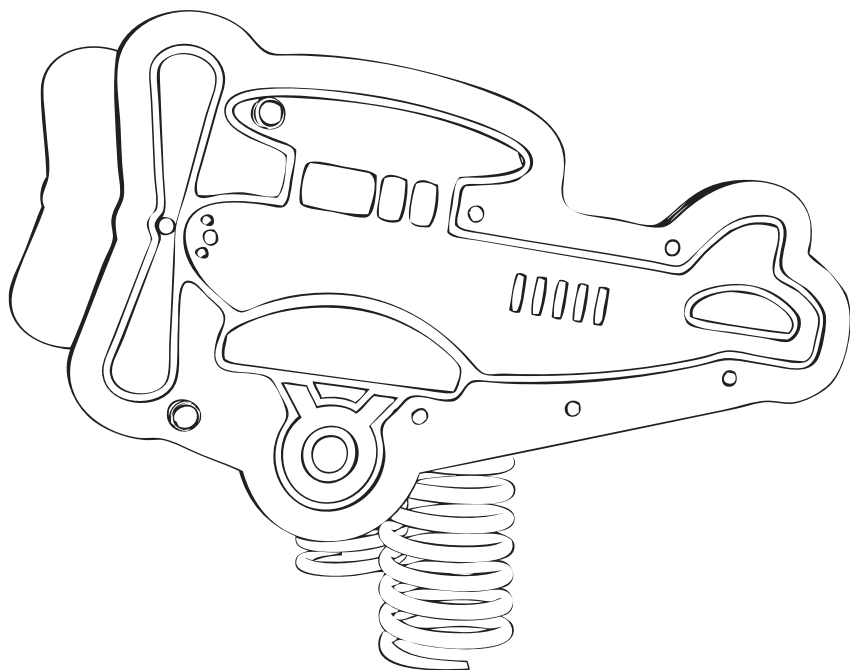

SR105 - AEROPLANE SPRINGER

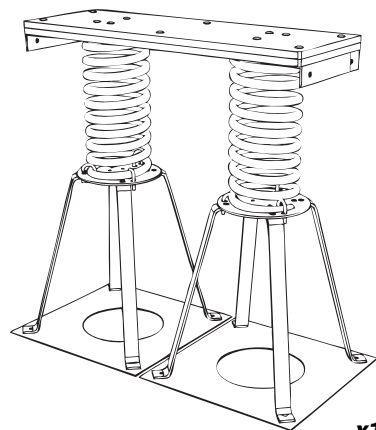

PRE-ASSEMBLED SEAT / SPRINGS

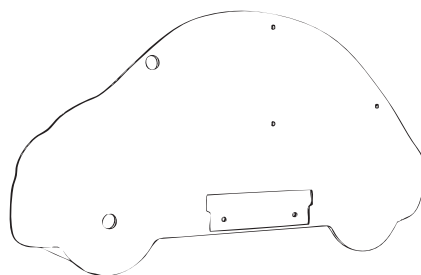

'RIGHT SIDE' INSIDE

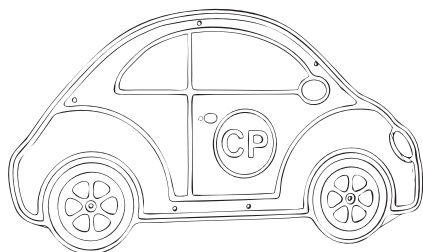

'RIGHT SIDE' OUTSIDE CAR

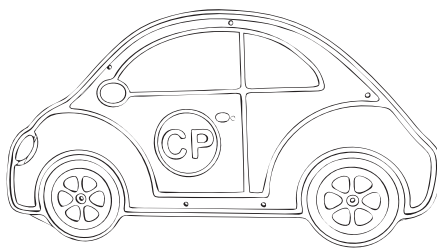

'LEFT SIDE' OUTSIDE CAR

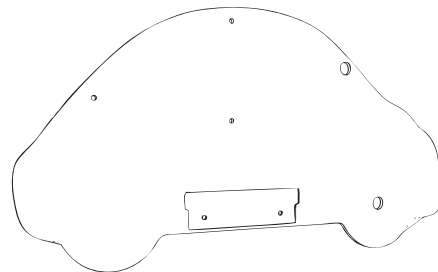

'LEFT SIDE' INSIDE

ABOVE PARTS SUPPLIED WITH SPRING ASSEMBLY

ADDITIONAL PARTS

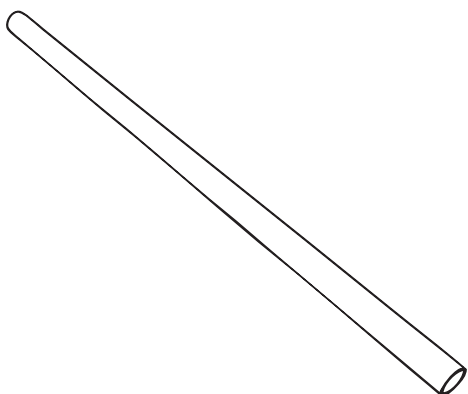

x2

GLAV TUBE OD 33.7MM

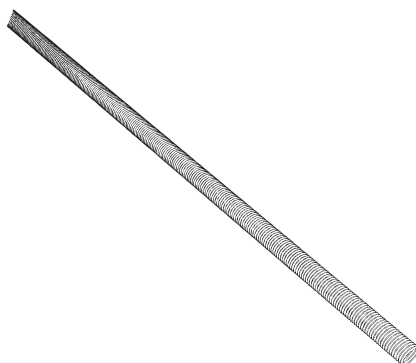

x2

THREAD BAR 975MM

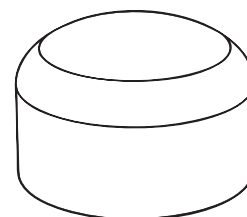

x4

M12 COVERED END CAP

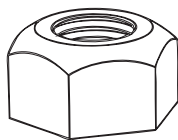

x4

N12 (NYLOC)

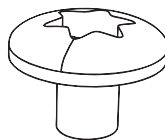

x12

TORKTAINER - N1

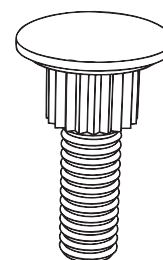

x12

TORKTAINER - 3B

CAR SPRINGER SHOWN, THIS HAS BEEN USED FOR VISUALS ONLY

FOUNDATION DETAILS

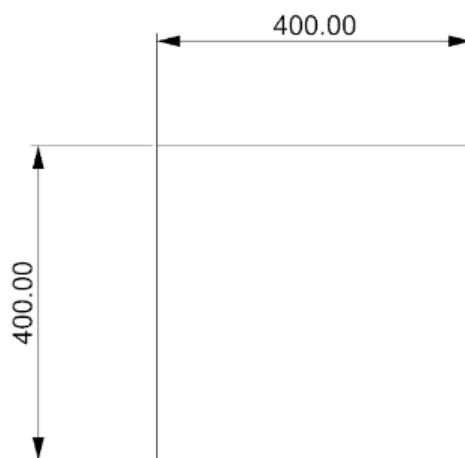
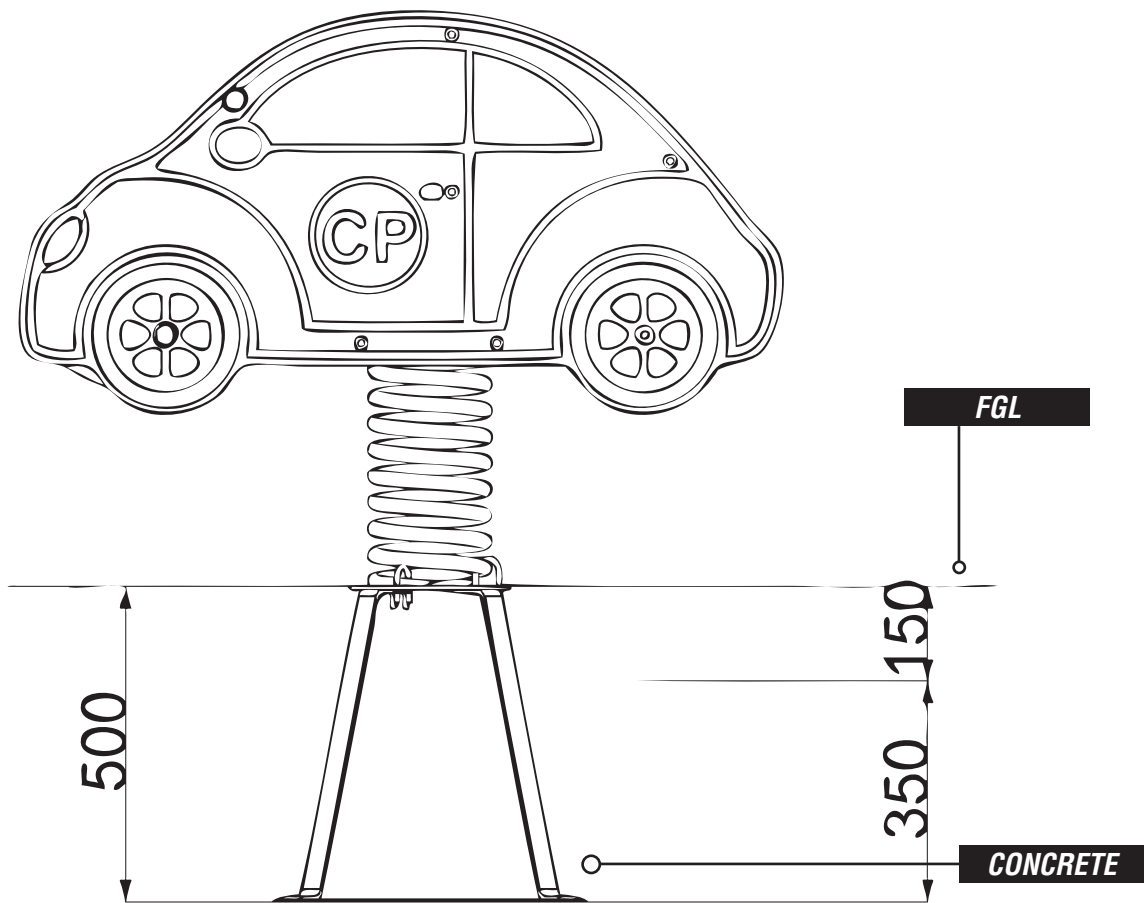

SURFACING DETAILS

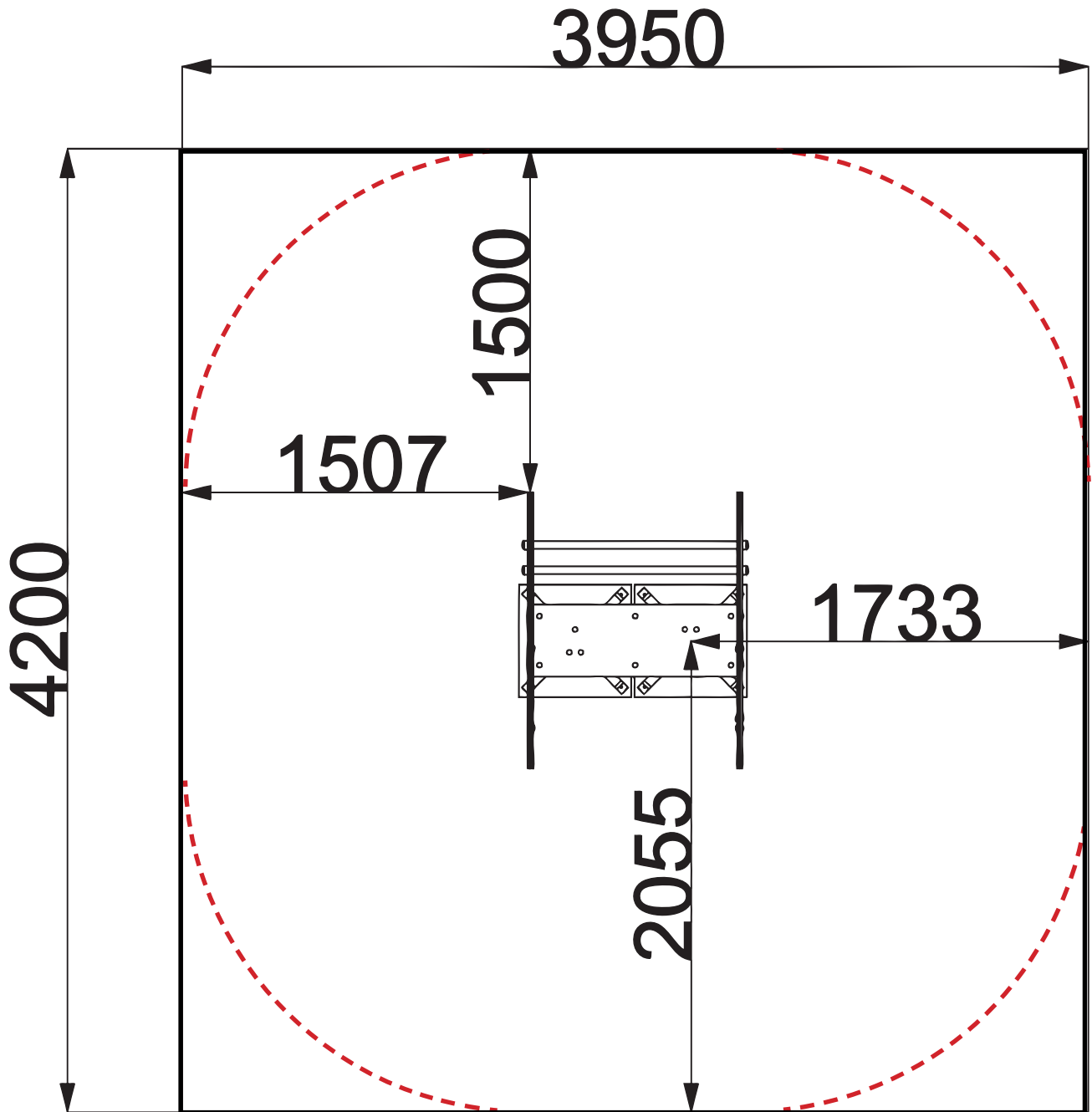

INSTALLATION INSTRUCTIONS

1

ASSEMBLE LEFT and RIGHT, INSIDE and OUTSIDE playtec parts

Using 4 X 3B / 4 X N1 TORKTAINERS (EACH SIDE) - AT THIS STAGE - ONLY FIX HOLES SHOWN BELOW

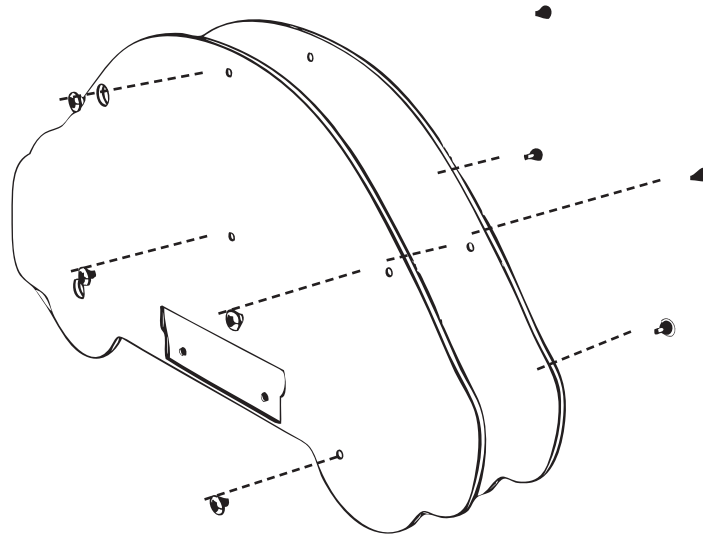

2

ATTACH PRE-ASSEMBLED SIDE TO SEAT BRACKET

USING 2 X 3B/ 2 X N1 TORKTAINERS - EACH SIDE

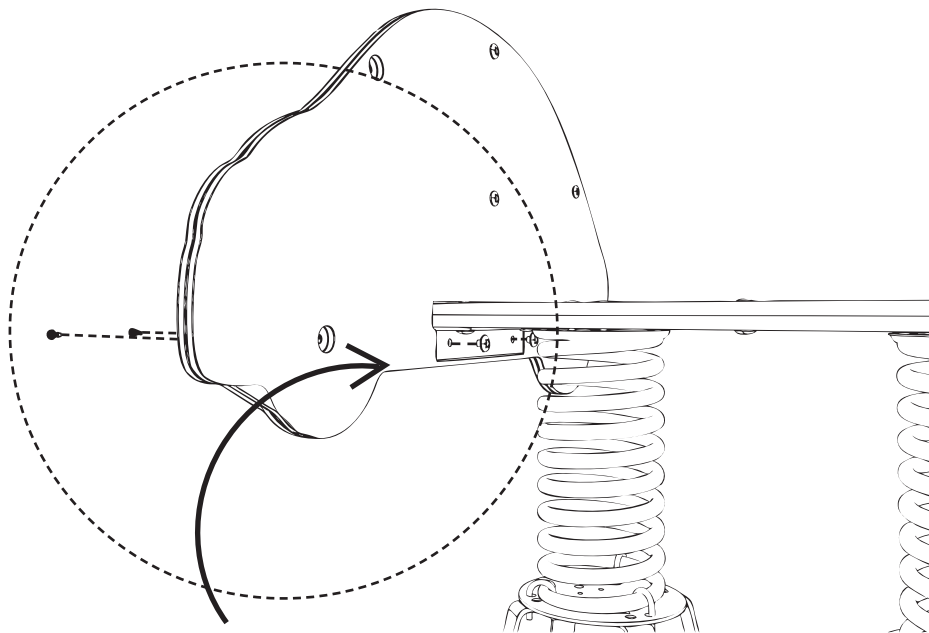

ENSURE:

SEAT BRACKET SITS WITHIN RECESSED PART OF THE PLAYTEC

INSTALLATION INSTRUCTIONS

3

ATTATCH HANDLE AND FOOTREST TO PLAYTEC SIDES

Using 975mm THREAD BAR (INSERT INSIDE GALV TUBE) and 2 X M12 NYLOCS / 2 X Covered end - (PER SIDE)

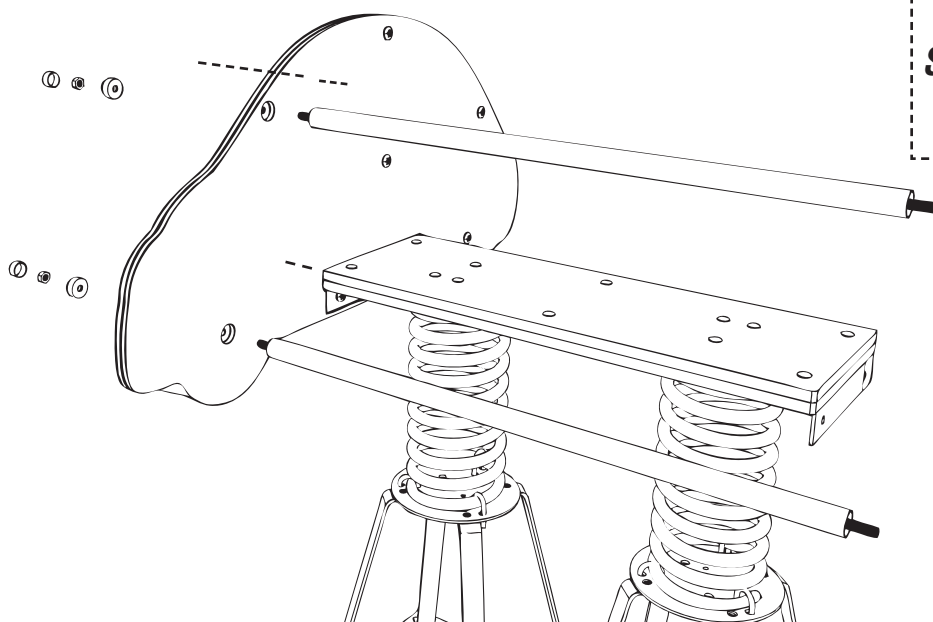

**REPEAT
STEP 2 and 3 FOR**

NOTES:

- SAME ASSEMBLY PROCESS FOR ALL SPRING RIDERS (DOUBLE)

ADDITIONAL DIMENSIONS

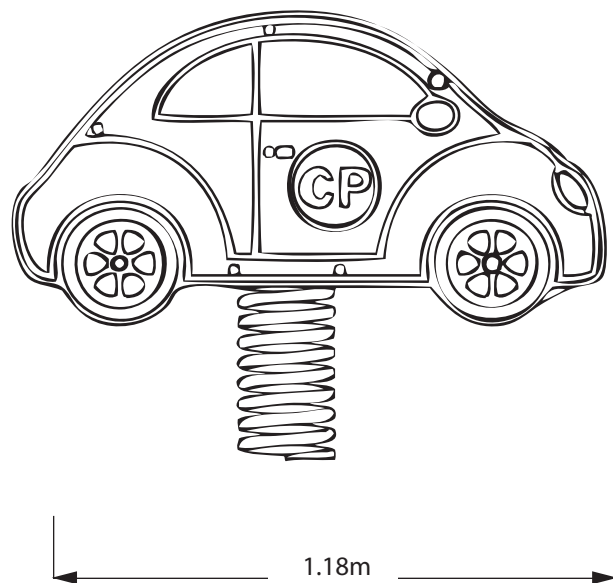
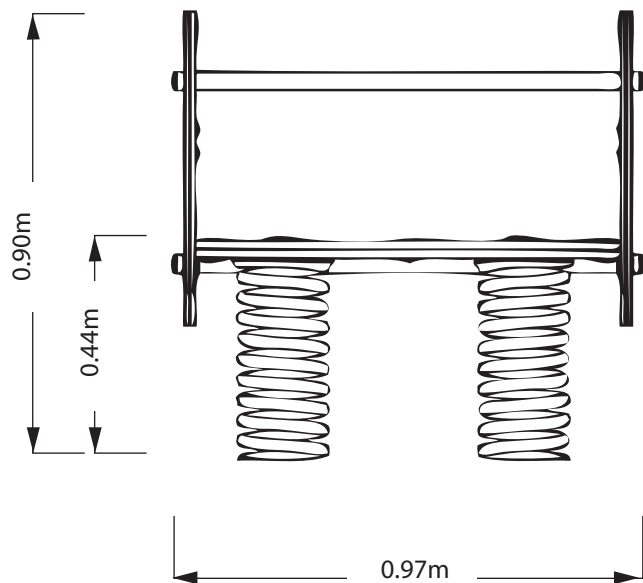

SEAT HEIGHT - 0.44MM