

AEROPLANE SPRING RIDER - DOUBLE

creative
play

SR105

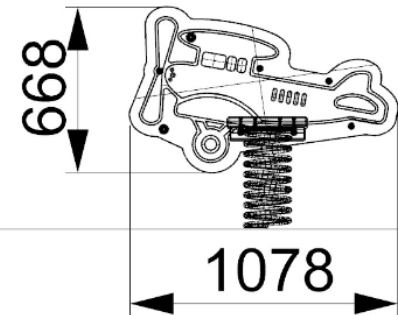
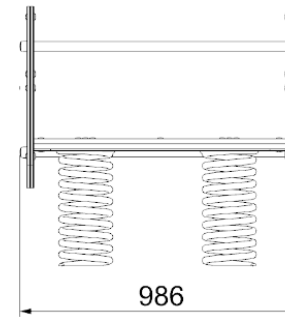
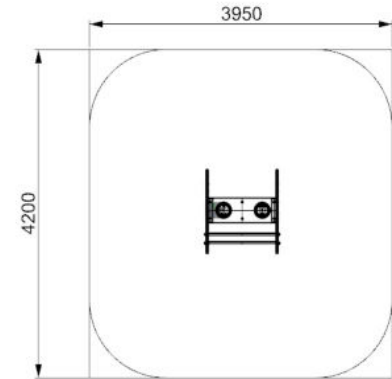
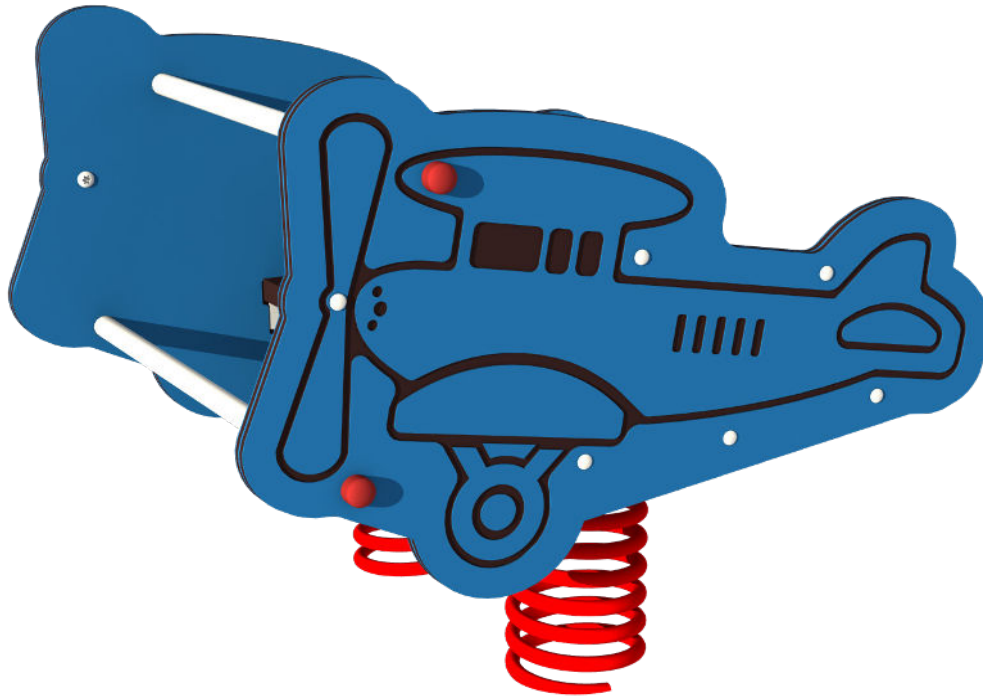

**Measurements in millimetres*

PRODUCT INFORMATION

PRODUCT CODE SR105

DIMENSIONS LXWXH 1.08 X 0.99M X 0.67M

AGE RANGE 3+

SPARE PART AVAILABILITY 2-4 WEEKS

TECHNICAL INFORMATION

FREE FALL HEIGHT 0.5M

MINIMUM AREA 3.95MX4.2M

MIN. SURFACING AREA 17 SQM

STANDARDS COMPLIANCE BSEN1176

DOWNLOADS

PRODUCT WEBPAGE 

MAINTENANCE INFORMATION 

**Information correct at time of creation*