

SR101 - HORSE SPRING RIDER (SINGLE) Installation Instructions

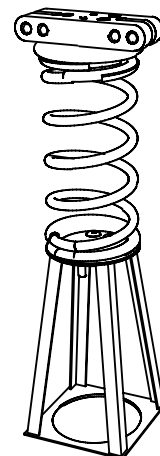

x1

SPRING ASSEMBLY SET

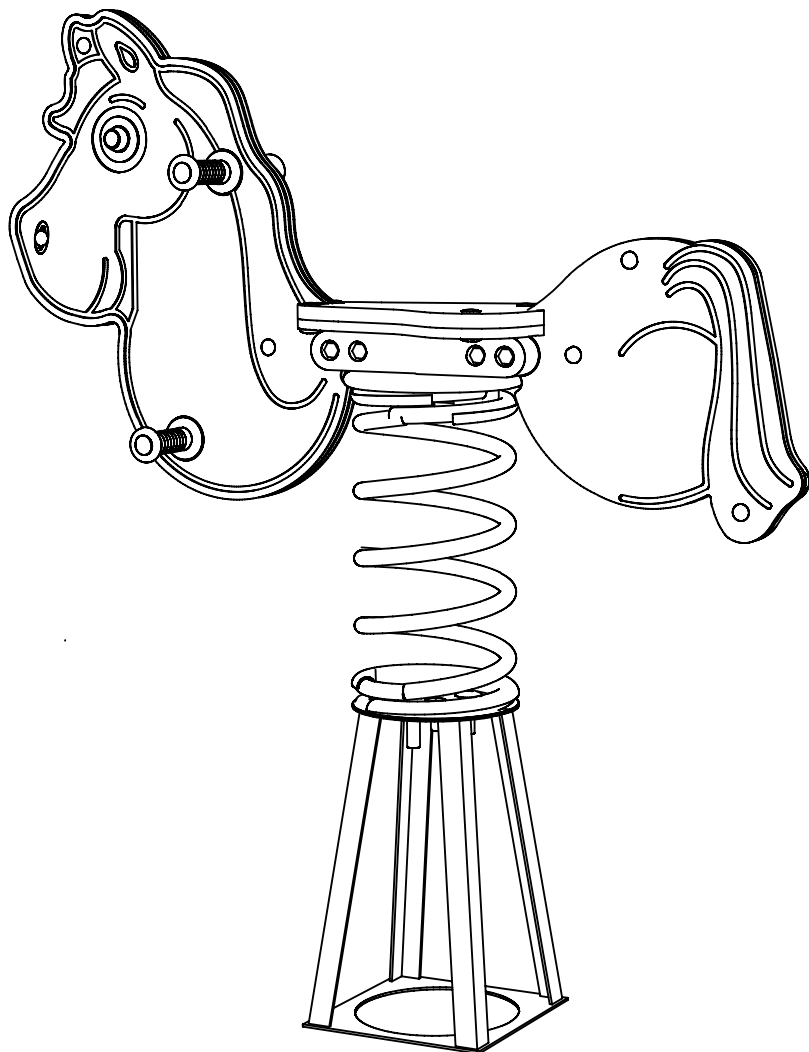
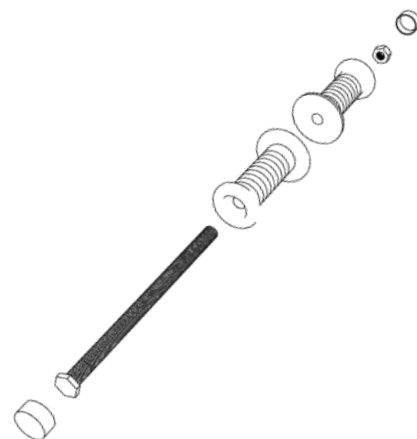

x2

HANDLE ASSEMBLY (SETS)

SR101 - HORSE SPRINGER



x1

EYE ASSEMBLY (SETS)

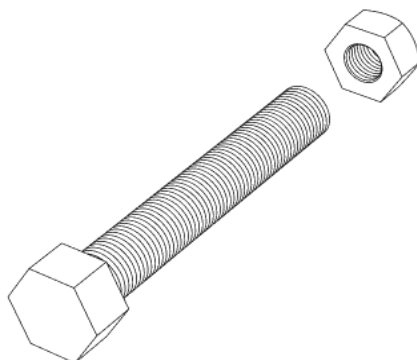

x4

M10 BOLT (INC NUT)

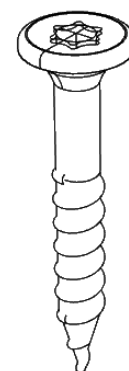

x2

M6 PLAYTEC SEAT SCREW

ABOVE PARTS SUPPLIED WITH SPRING ASSEMBLY

ADDITIONAL PARTS

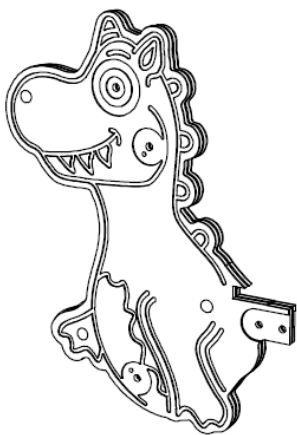

x1

FRONT



x1

BACK



x1

SEAT (EKO GRIP)



x1

SEAT (PLAYTEC)

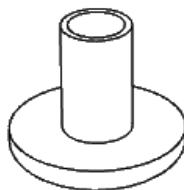

x4

TORKTAINER - 3B

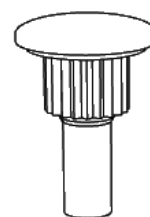

x4

TORKTAINER - N3

DRAGON SPRINGER SHOWN, THIS HAS BEEN USED FOR VISUALS ONLY

FOUNDATION DETAILS

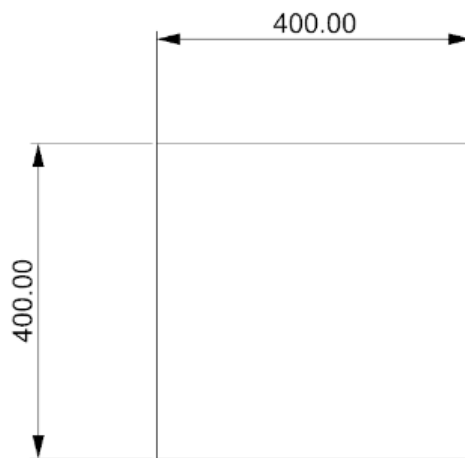
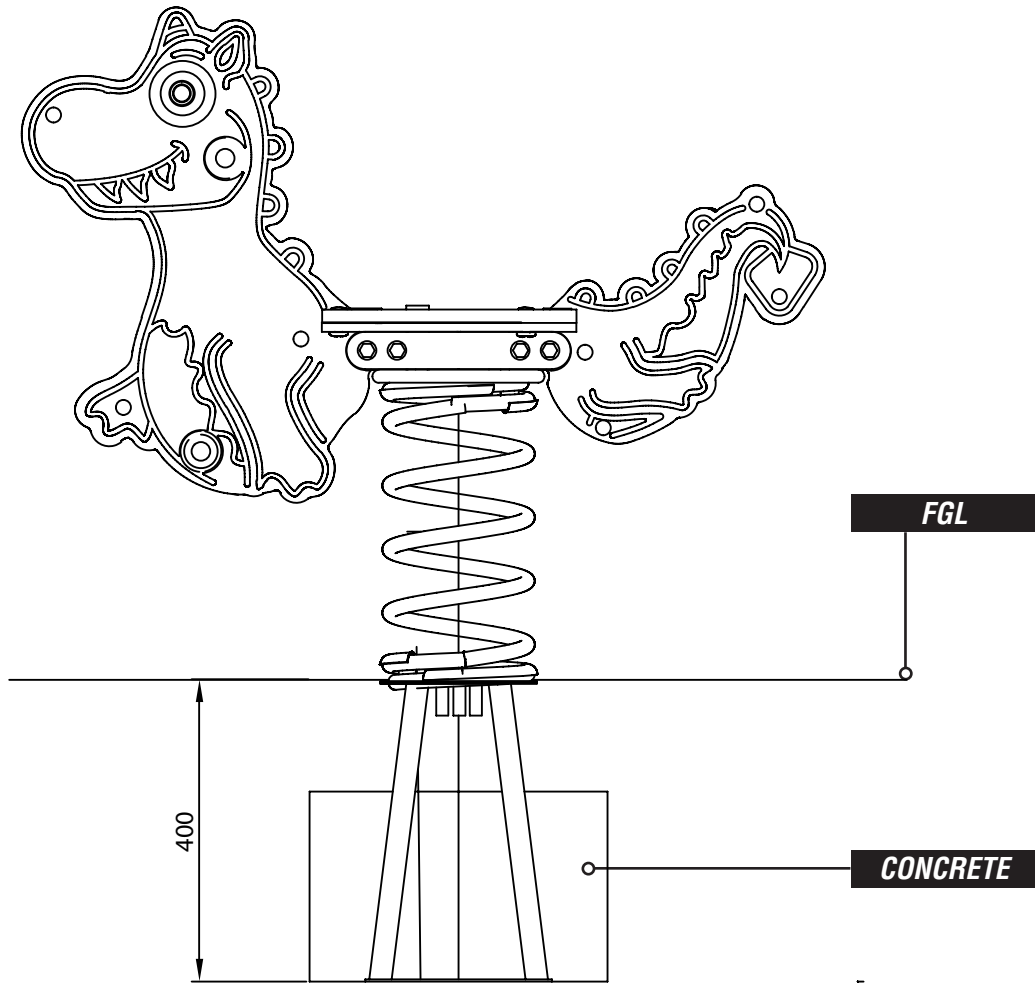

SURFACING DETAILS

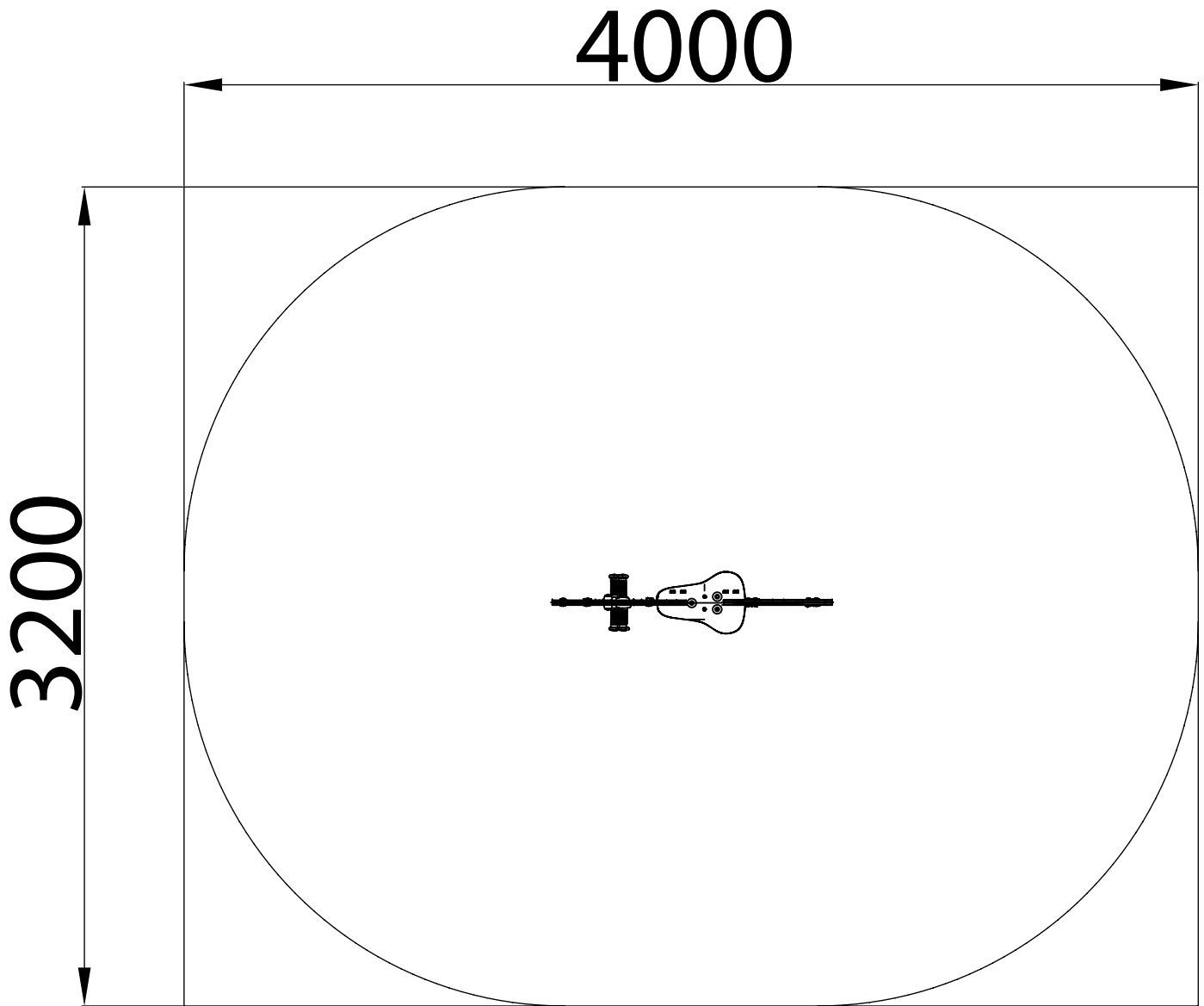

INSTALLATION INSTRUCTIONS

1 SCREW SEAT ON SPRING ASSEMBLY USING - SEAT (PLAYTEC) & SCREWS

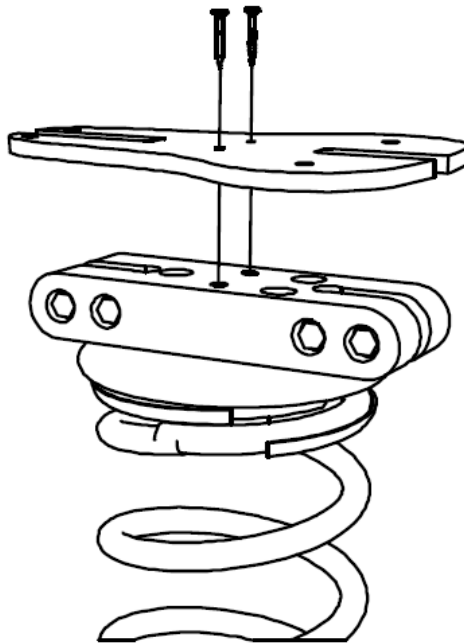

2 ATTATCH THE SEAT (EKO GRIP) USING TORKTAINERS 3B-N3

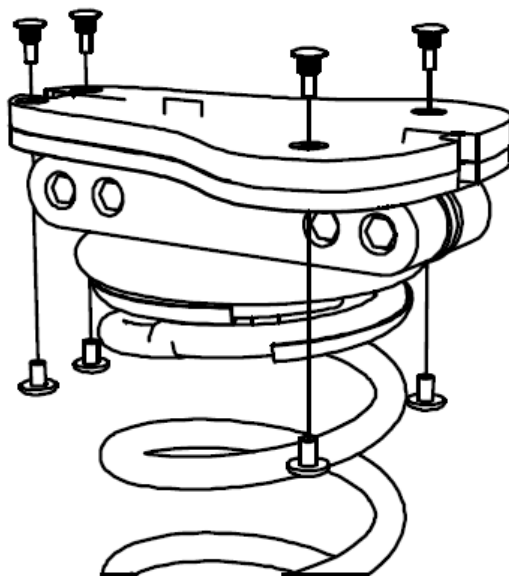

INSTALLATION INSTRUCTIONS

3 ATTATCH HANDLE / EYE SETS TO PLAYTEC USING HANDLE ASSEMBLY (SETS) / EYE ASSEMBLY (SETS)

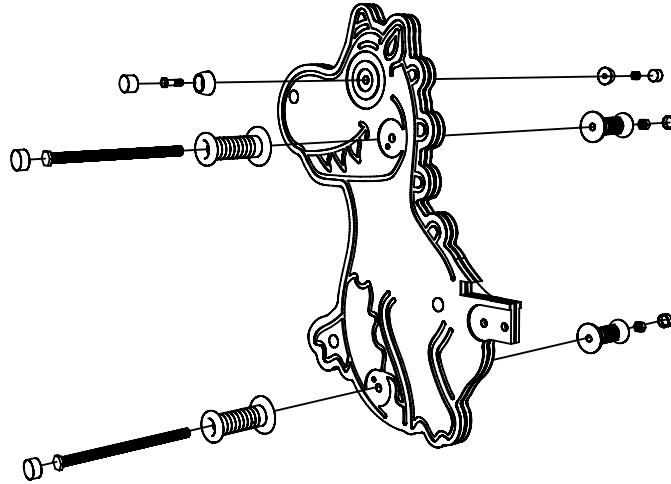

4 ATTATCH FRONT AND BACK PLAYTEC TO SPRING ASSEMBLY USING - BOLT (SET) - QUANTITY X 4

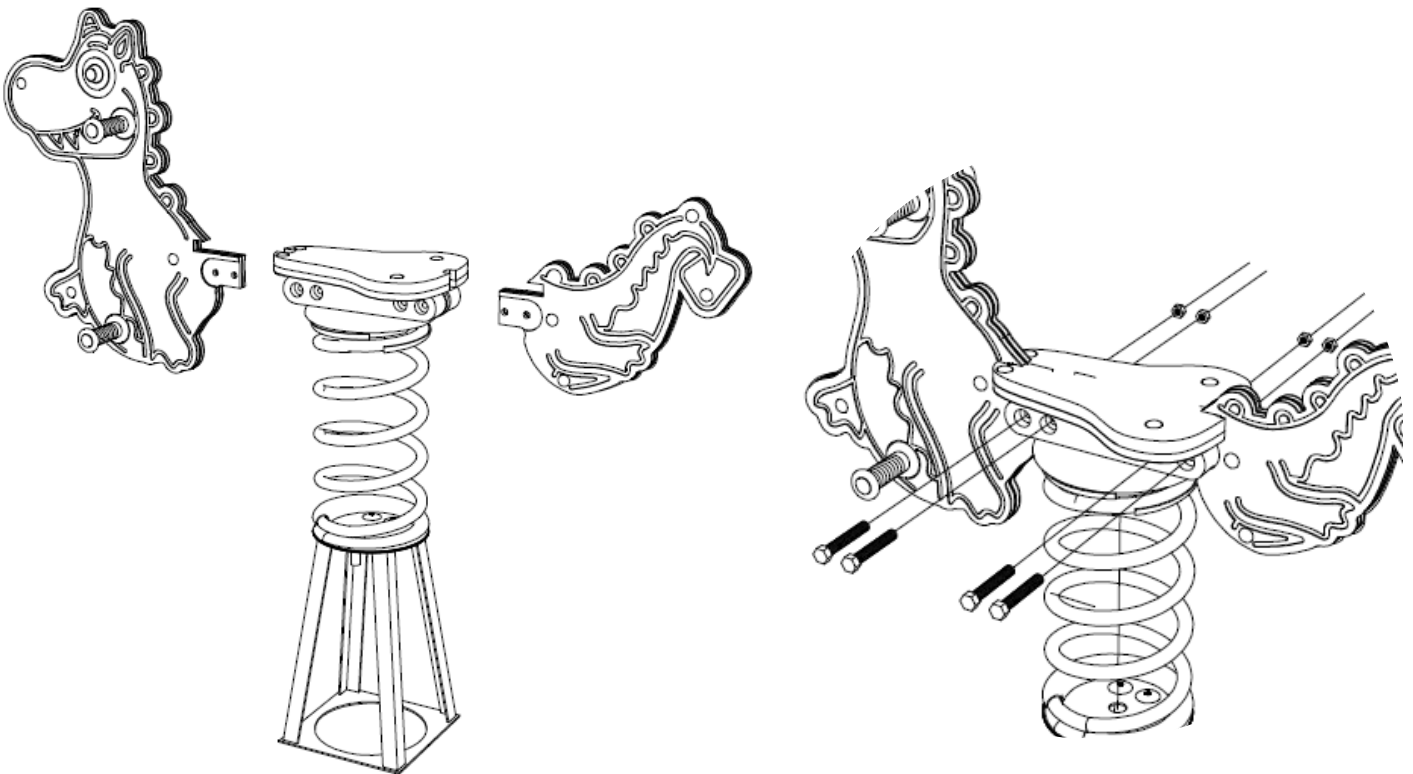

NOTES:
- SAME ASSEMBLY PROCESS FOR ALL SPRING RIDER ANIMALS (SINGLE)

ADDITIONAL DIMENSIONS

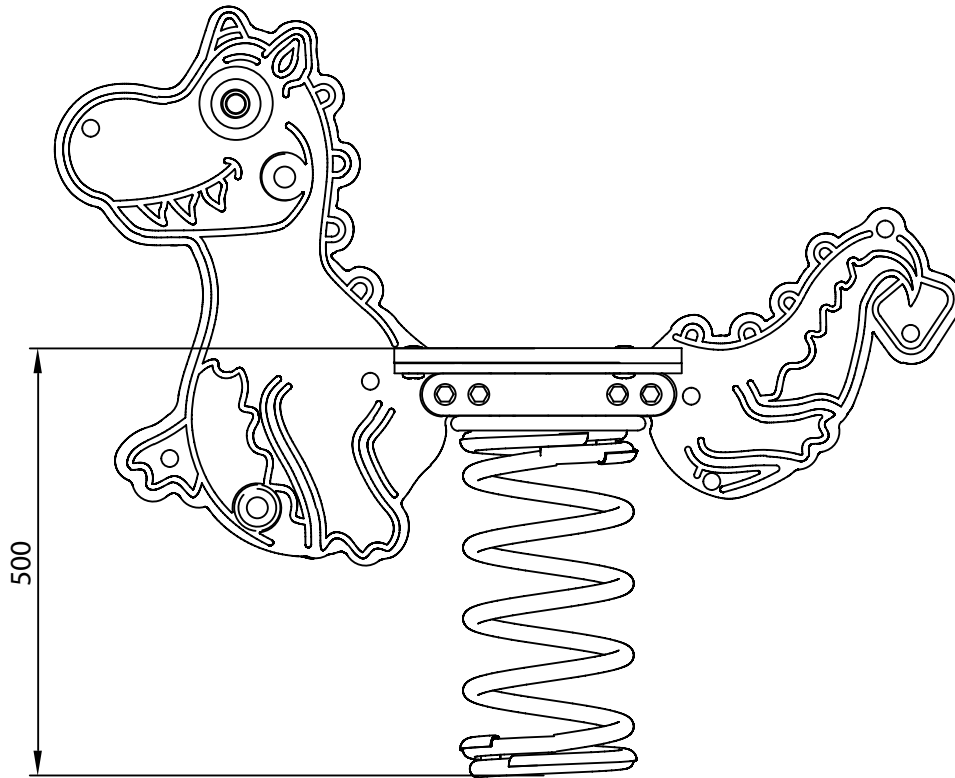

SEAT HEIGHT - 500MM