

S110-R - SINGLE SWING ROUND (FLAT SEAT)
Installation Instructions

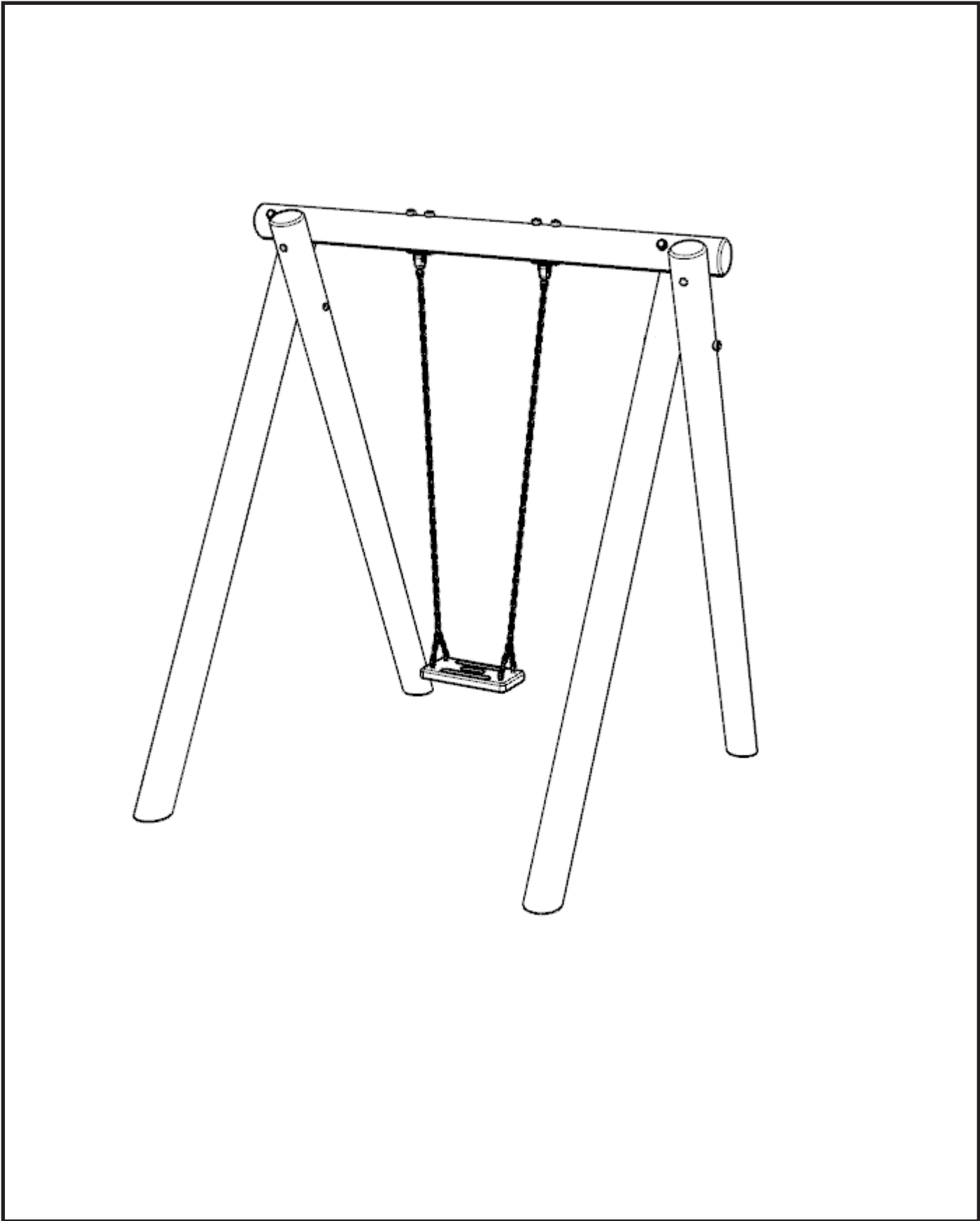

PARTS REQUIRED

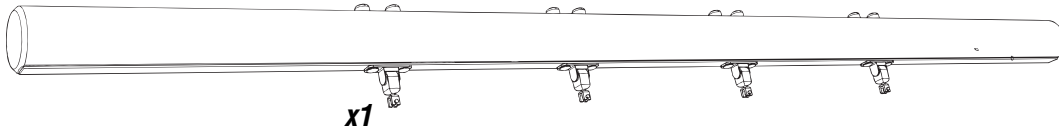

x1

TOP BEAM - SINGLE SWING



x4

UPRIGHTS S101R1



x1

FLAT SEAT (INC CHAIN)

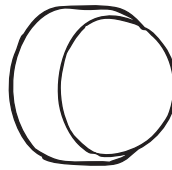

x4

BLACK M8 NUT CUP

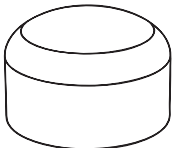

x6

END CAPS

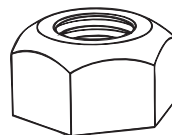

x6

M12 NYLOC NUT



x6

M12 x 320 SQUARE CUP BOLT

FOUNDATION DETAILS

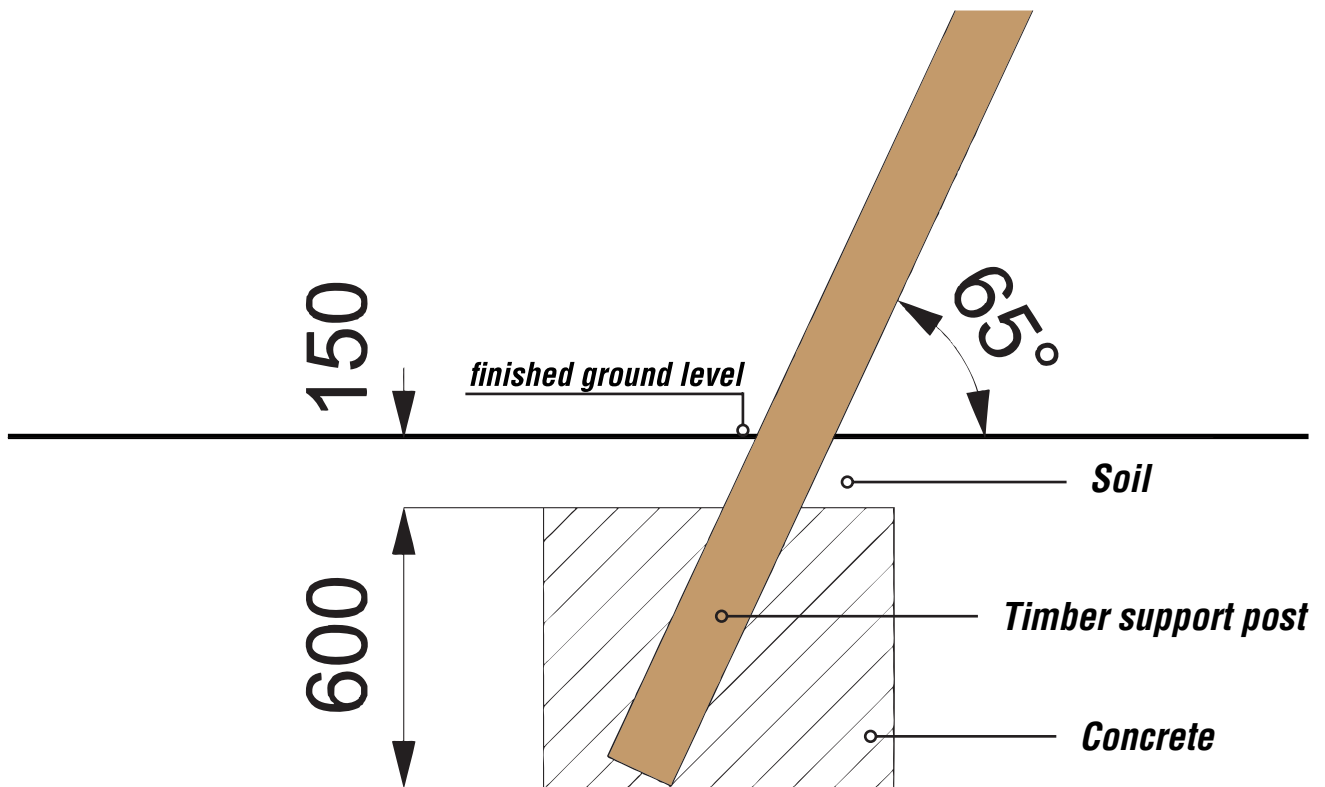
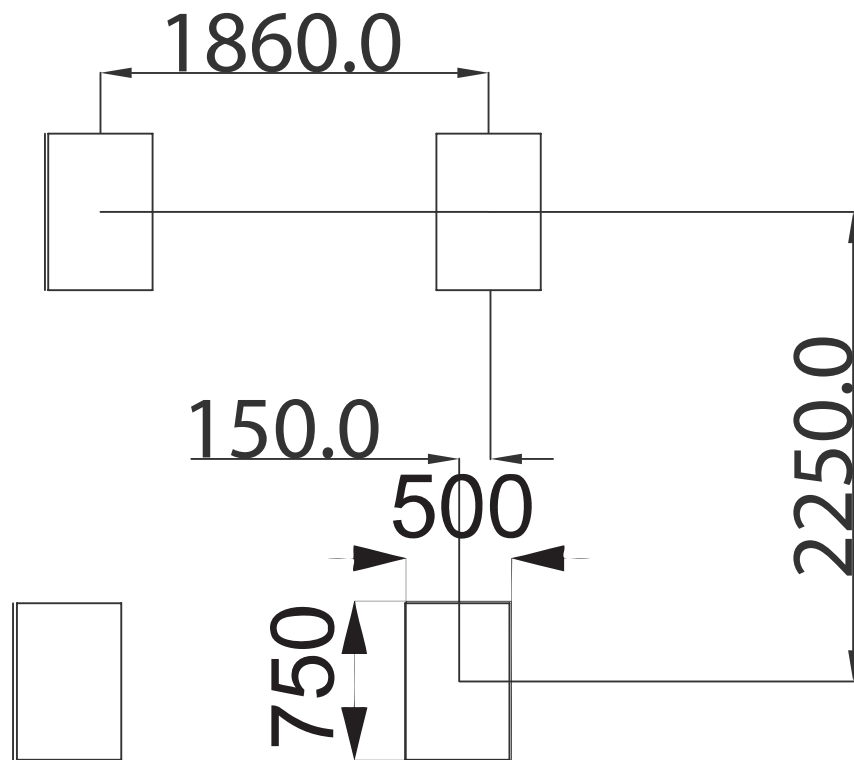

SURFACING DETAILS

----- = MINIMUM SPACE

———— = SURFACE AREA

■ = SYNTHETIC

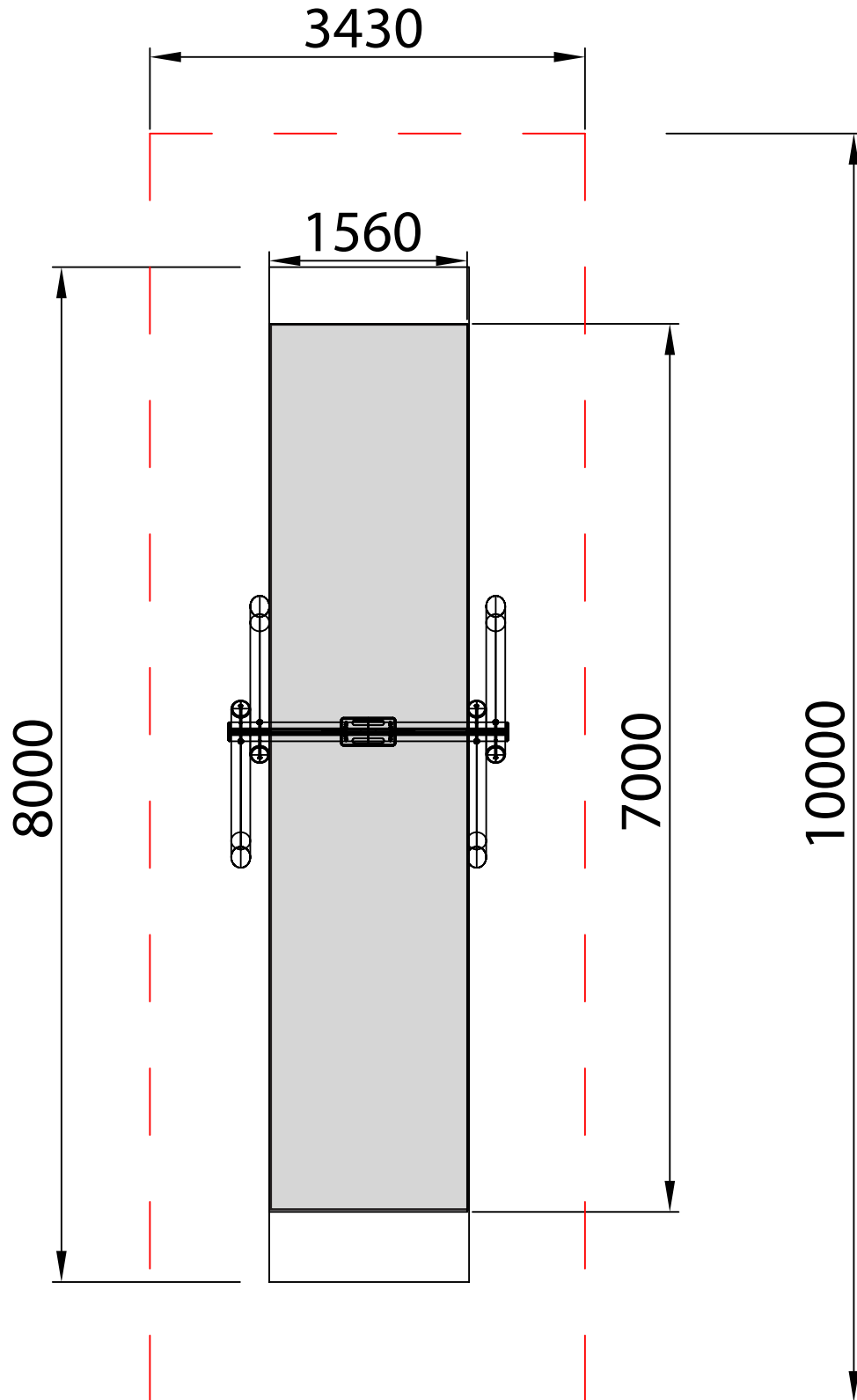

INSTALLATION INSTRUCTIONS

1 BUILD THE SINGLE SWING FRAME USING M12X310 X 6 / NYLOCS X 6/ END CAPS X6

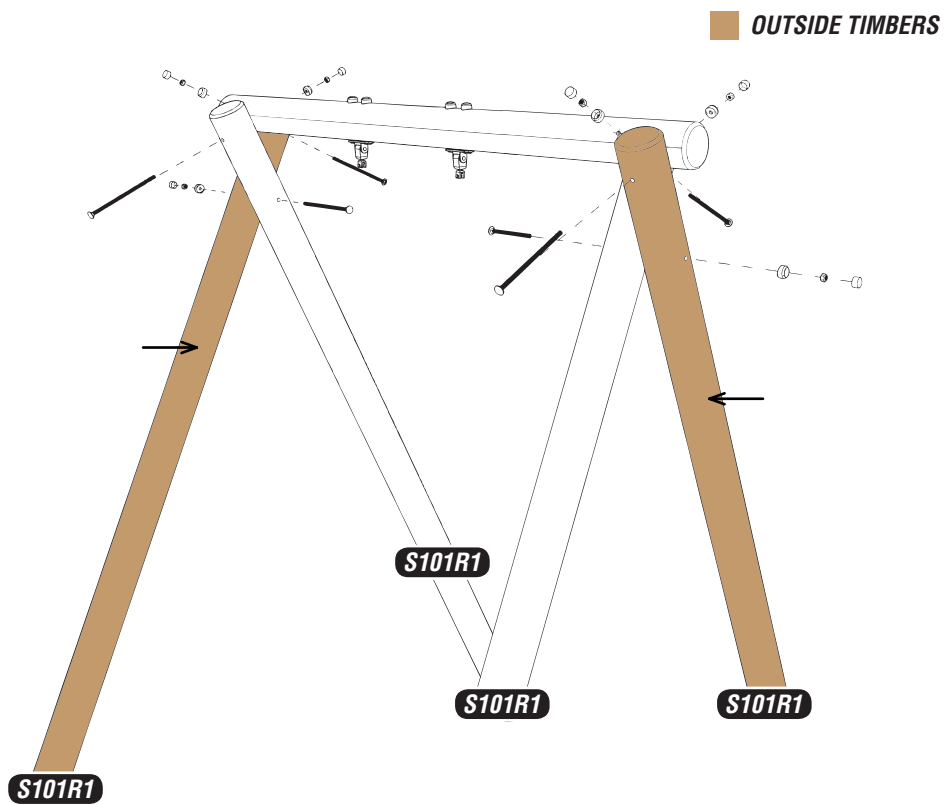

INSTALLATION INSTRUCTIONS

2

Install Assembly

Follow Foundation details

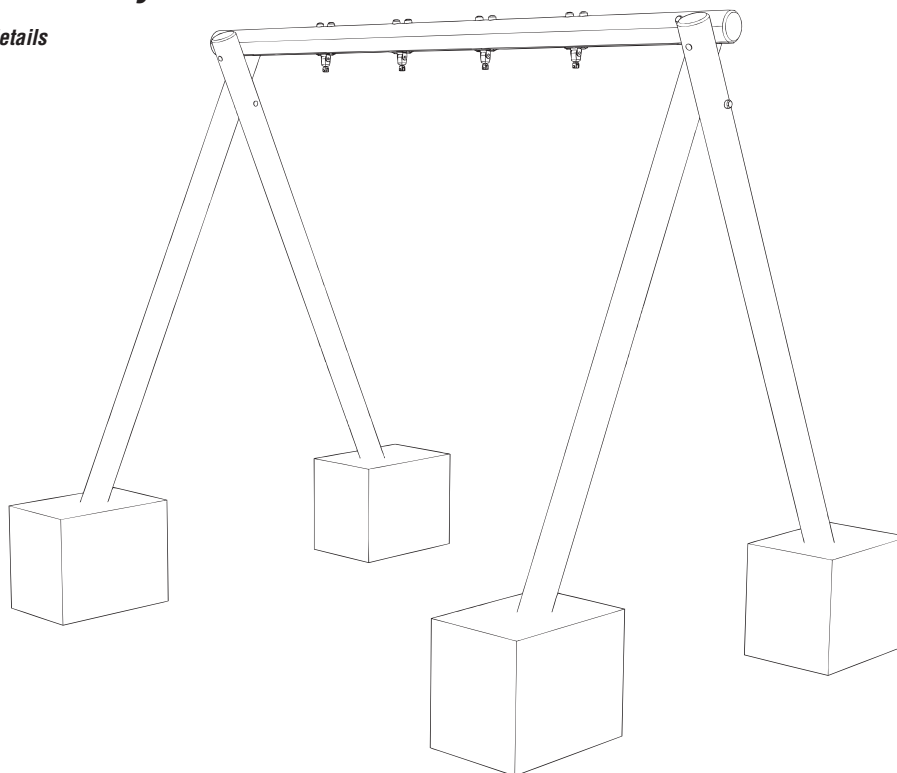

3

Install FLAT SEATS

USING M8 NUT CUP X4 . ADDITIONAL DIMENSIONS FOR SEAT HEIGHT

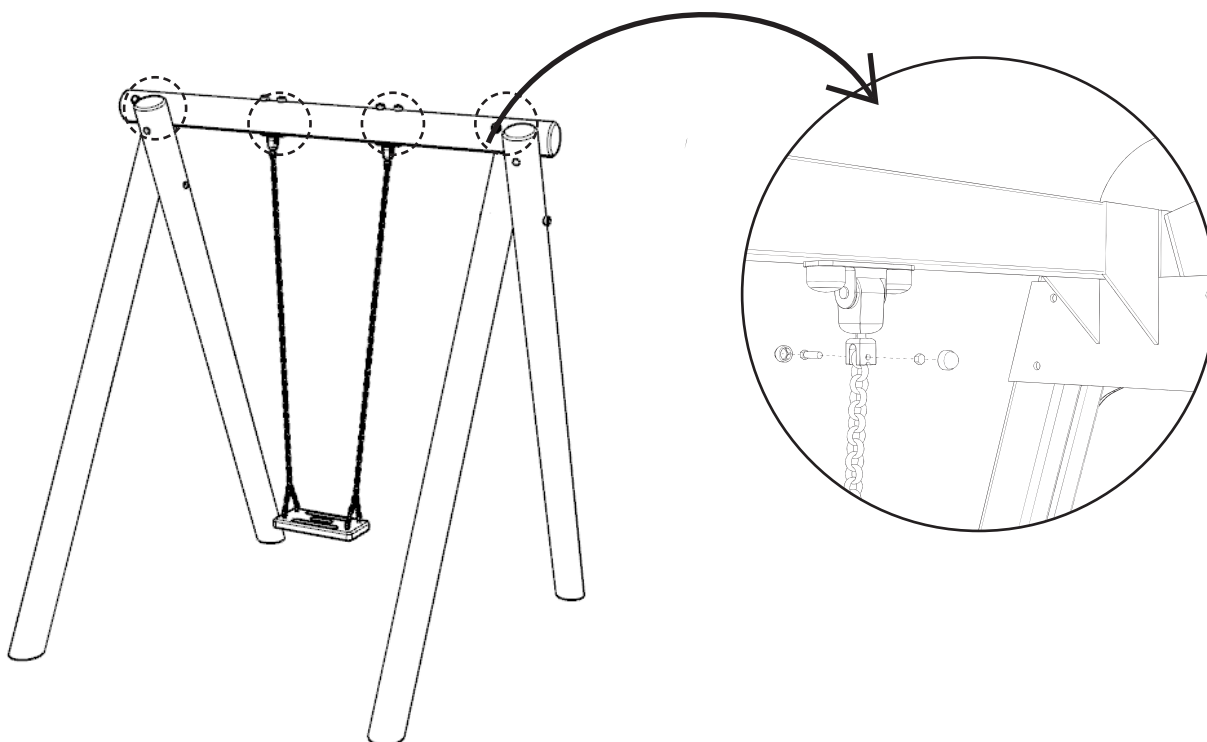

ADDITIONAL DIMENSIONS

SEAT HEIGHT BELOW

