

TELEPHONE TALK TUBES

Installation Instructions

creative
play

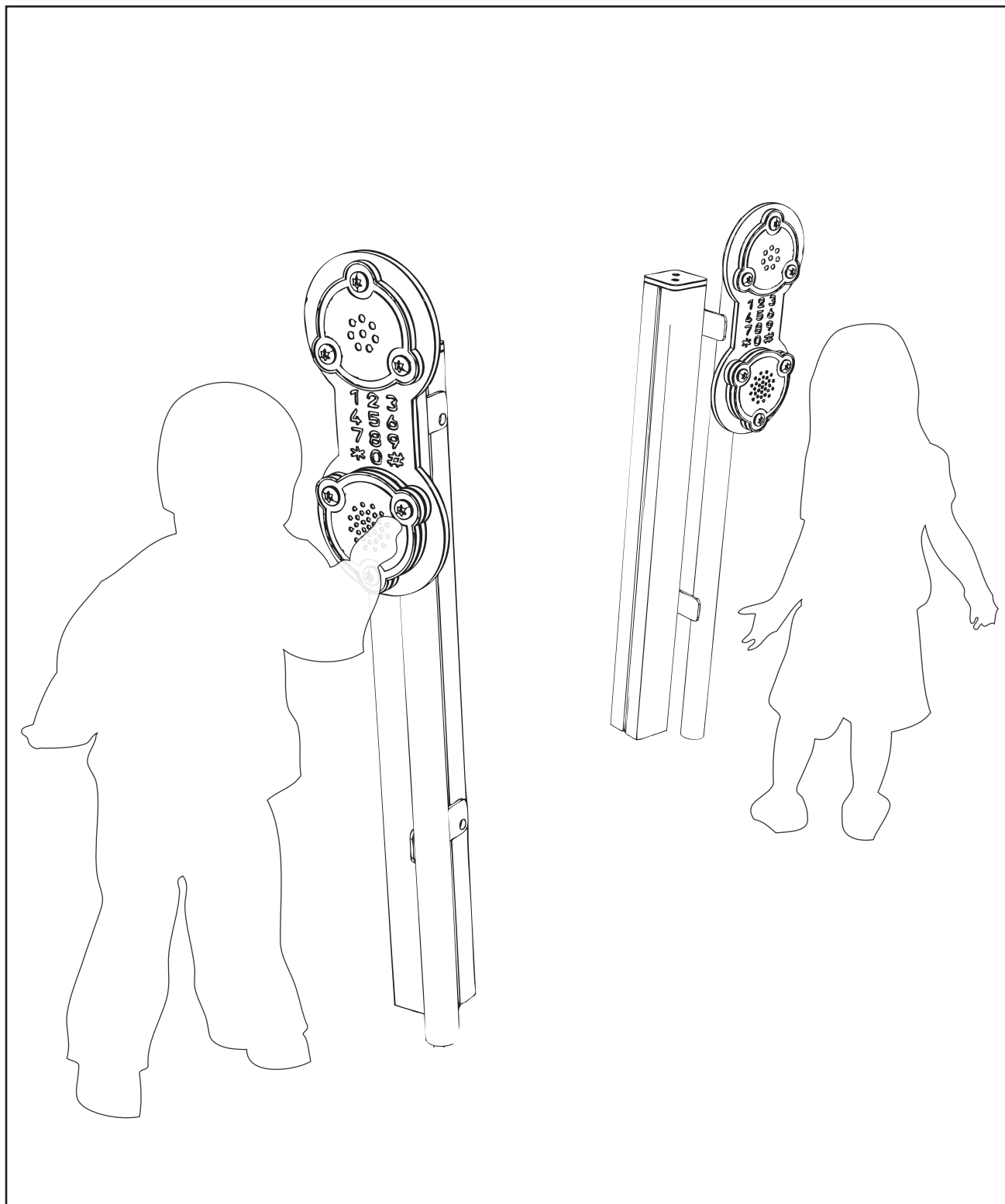

PARTS required

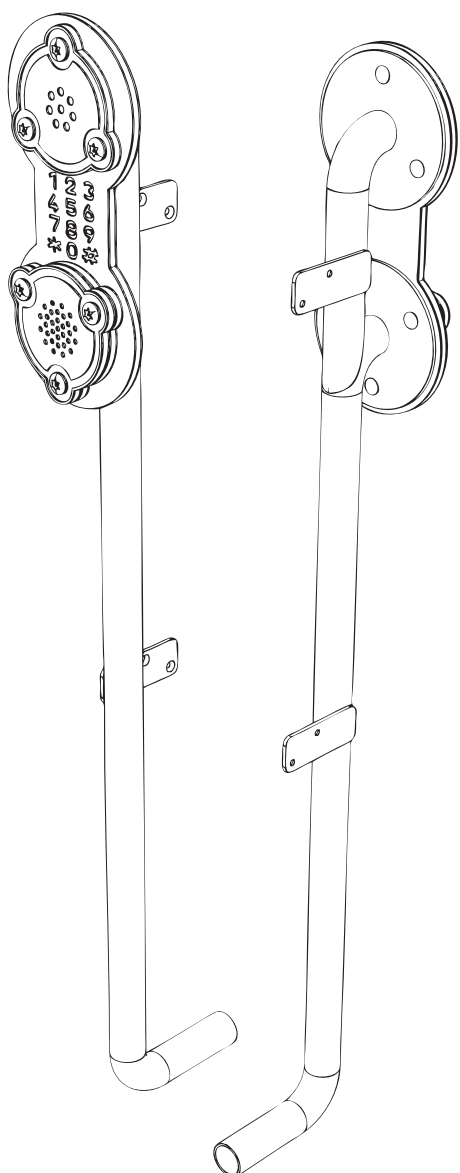

x2 (PRE-ASSEMBLED TELEPHONE TALK TUBES)

T1 **x2** 90mm x 90mm
(with end cap)

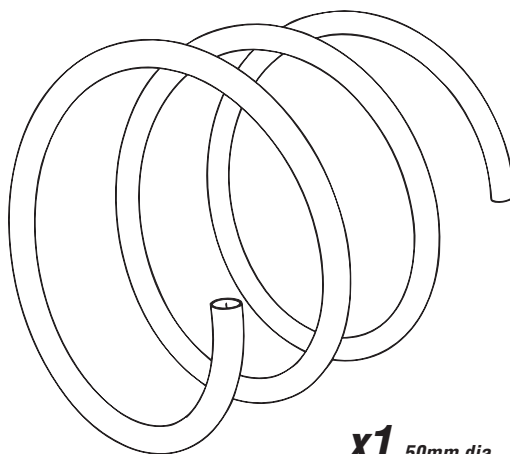

x1 50mm dia
tubing (10m approx.)

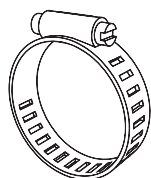
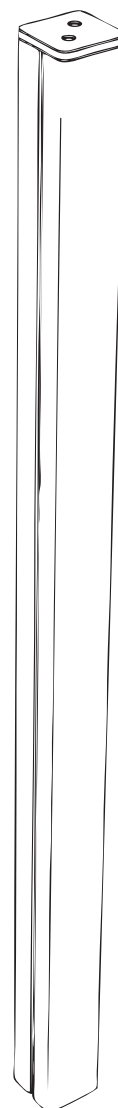

x4 jubilee clips



x8 (80mm brass screws)

TOOLS required

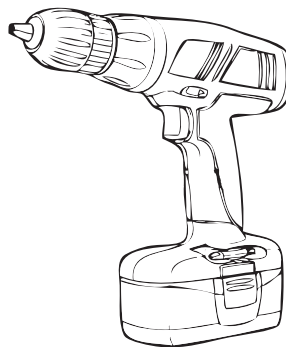

Foundation Details

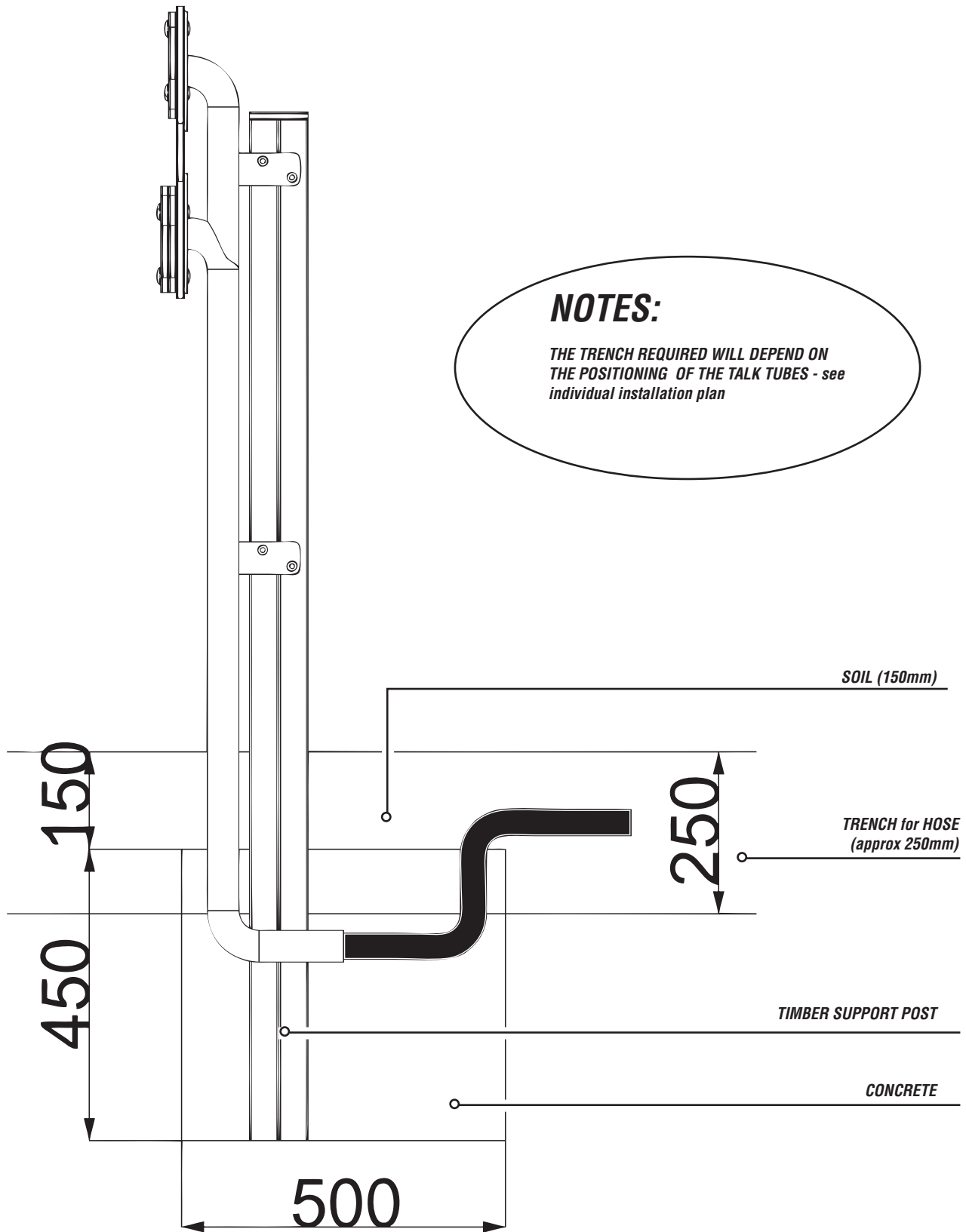

Assembly Instructions

1

Attach the T1 timbers to the TELEPHONE TALK TUBE assembly *Using FM80 'BRASS SCREWS'*

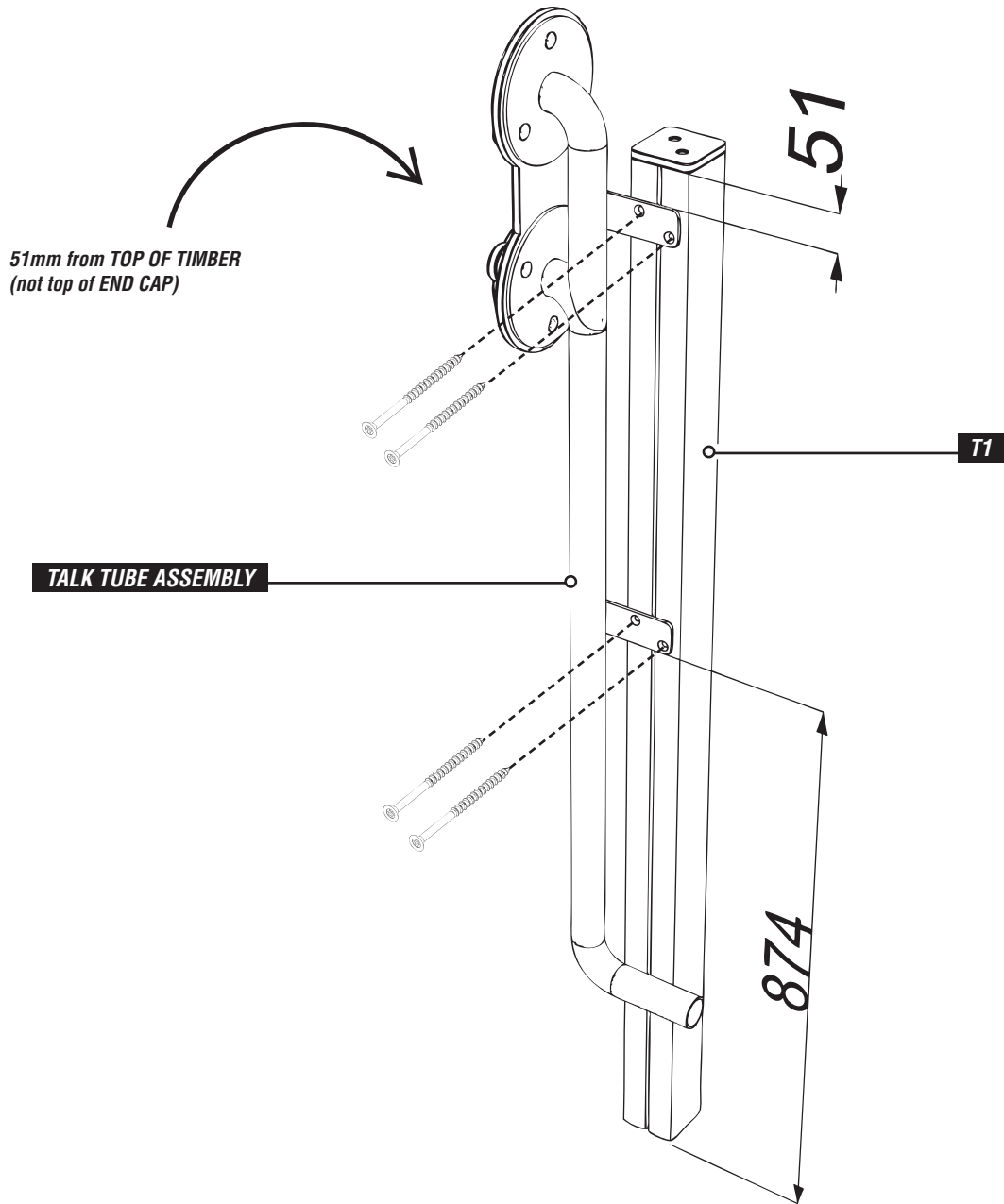

2

REPEAT for the second TELEPHONE TALK TUBE

Assembly Instructions

3

Attach the 50mm dia tubing to the ASSEMBLY

Using JUBILEE CLIPS - Use 2 either end to ensure

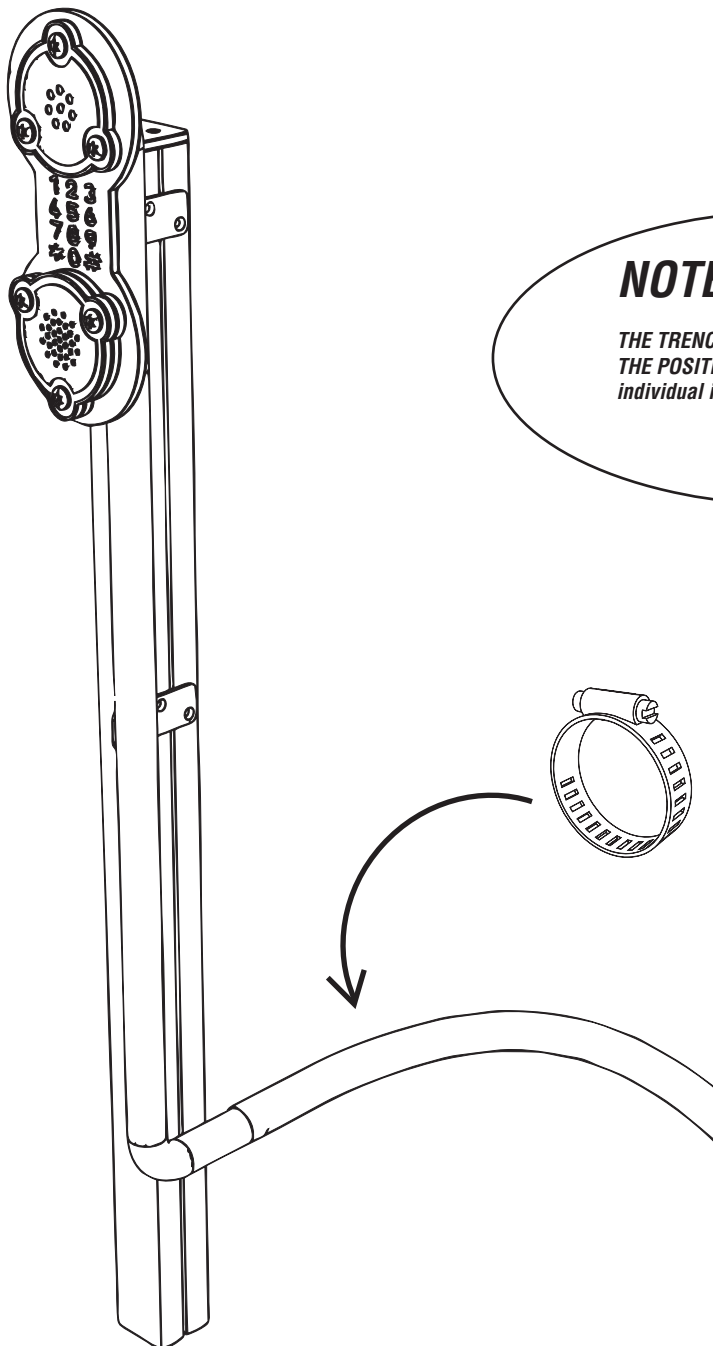

NOTES:

THE TRENCH REQUIRED WILL DEPEND ON
THE POSITIONING OF THE TALK TUBES - see
individual installation plan

REPEAT for the second TELEPHONE TALK TUBE

4