

S-SHAPED **SQUARE Modular Seating** *Assembly Instructions*

**creative
play**

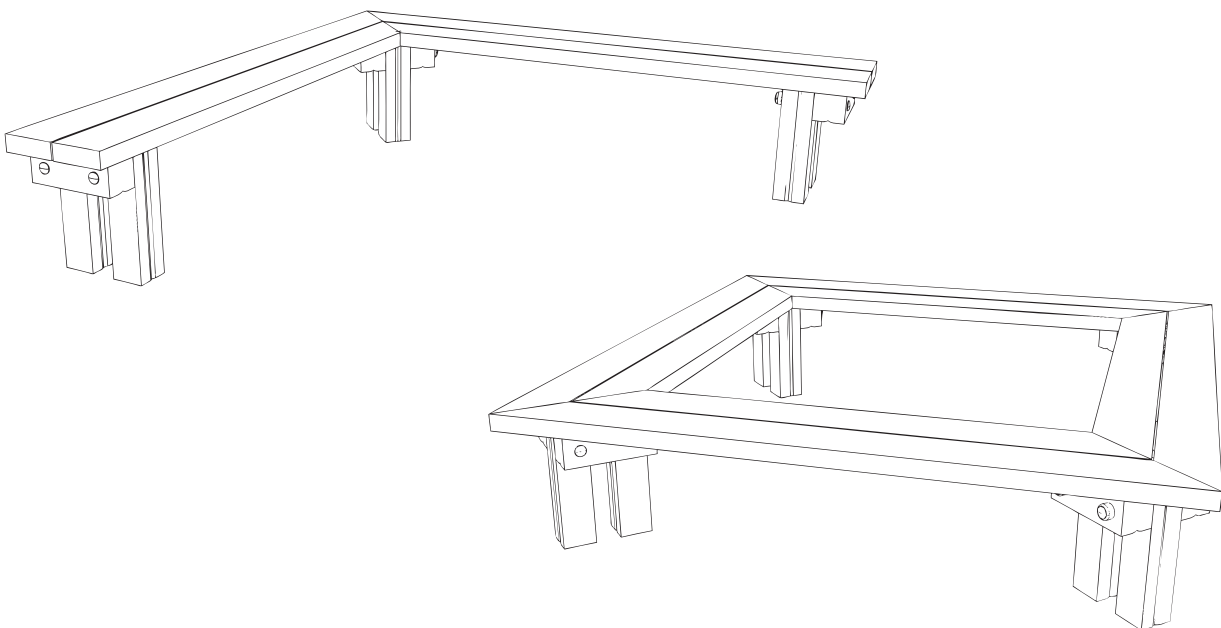
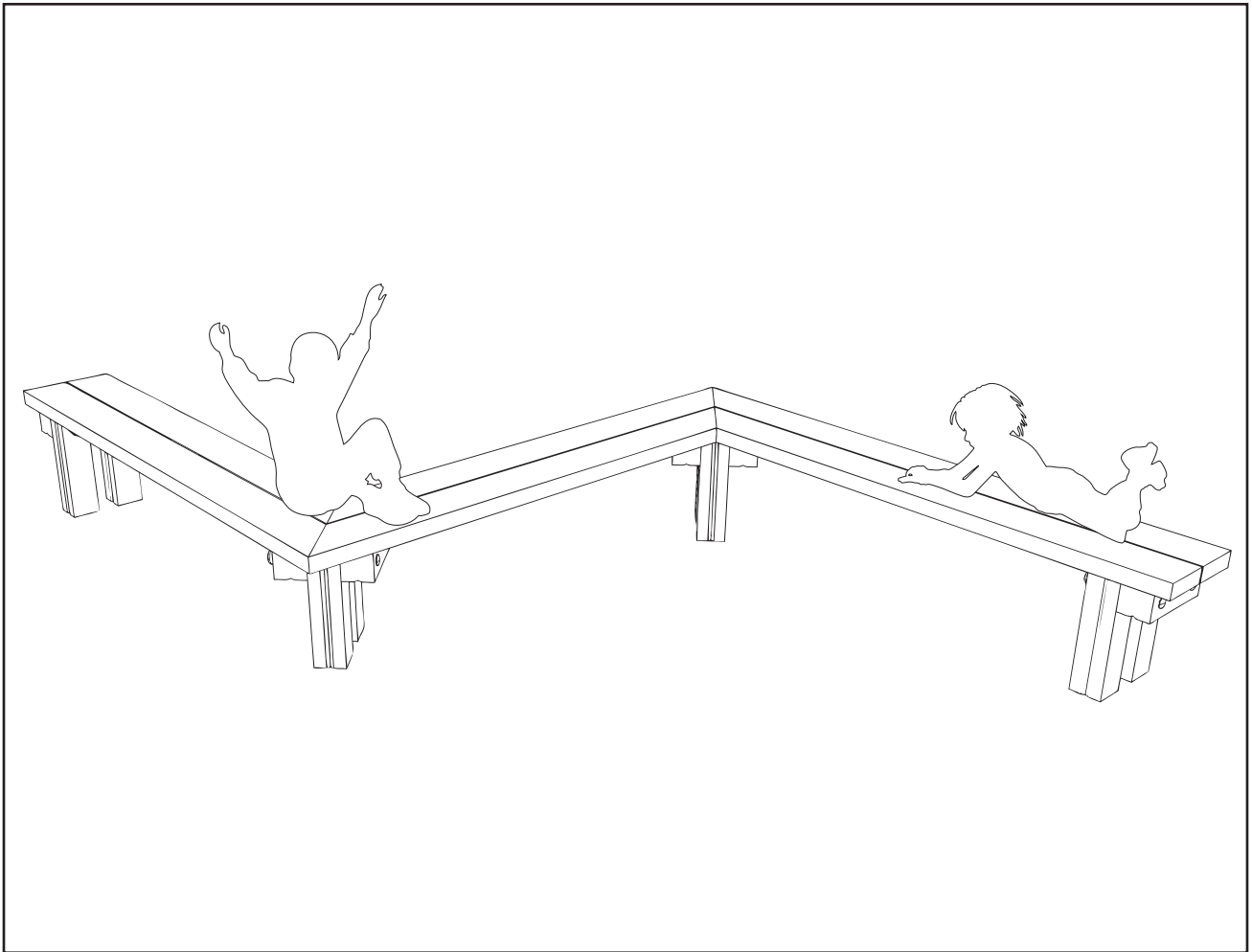

PARTS required

T1a QTY 2 (147mm x 47mm)

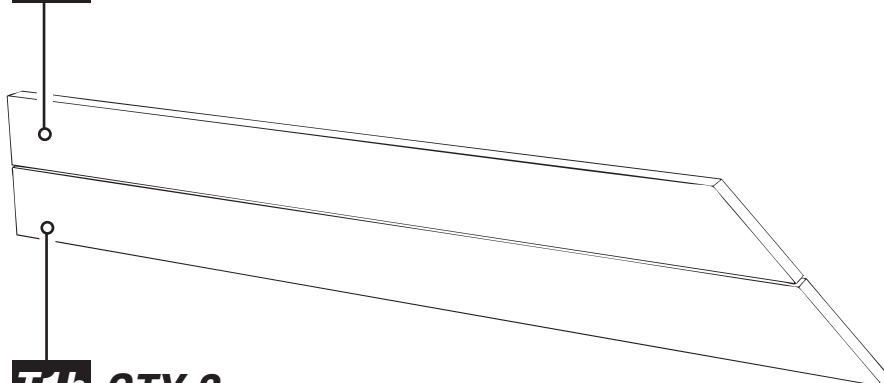

T1b QTY 2 (147mm x 47mm)

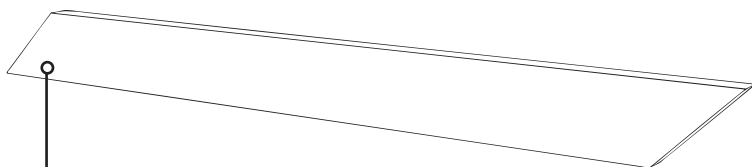

T2 QTY 2 (147mm x 47mm)

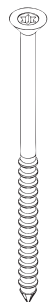

x24 (120mm brass screws)

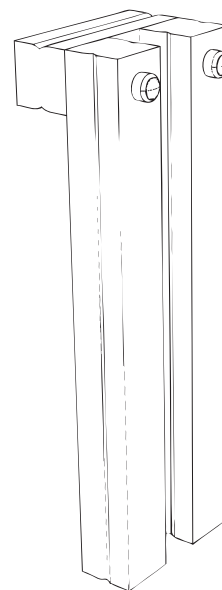

QTY 2 (single support)



QTY 2 (double support)

TOOLS required

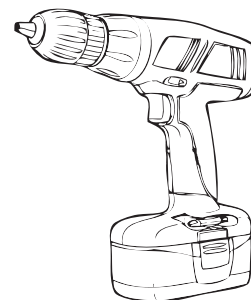
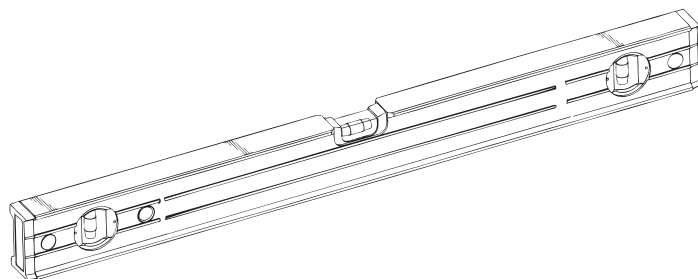

Foundation Details

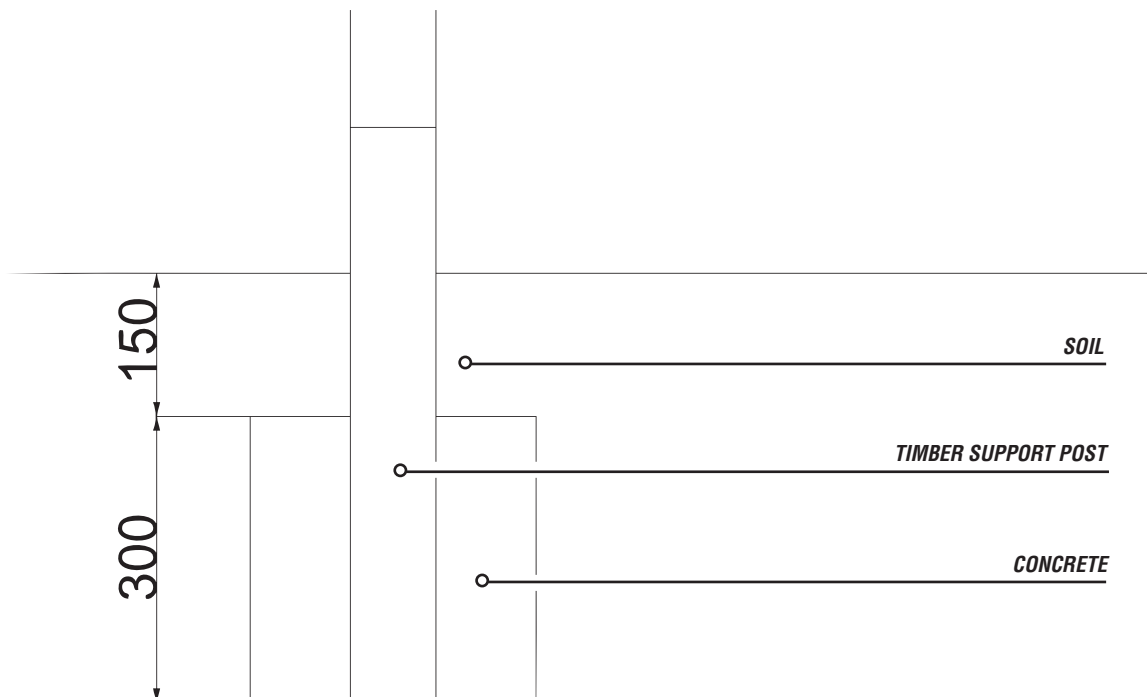
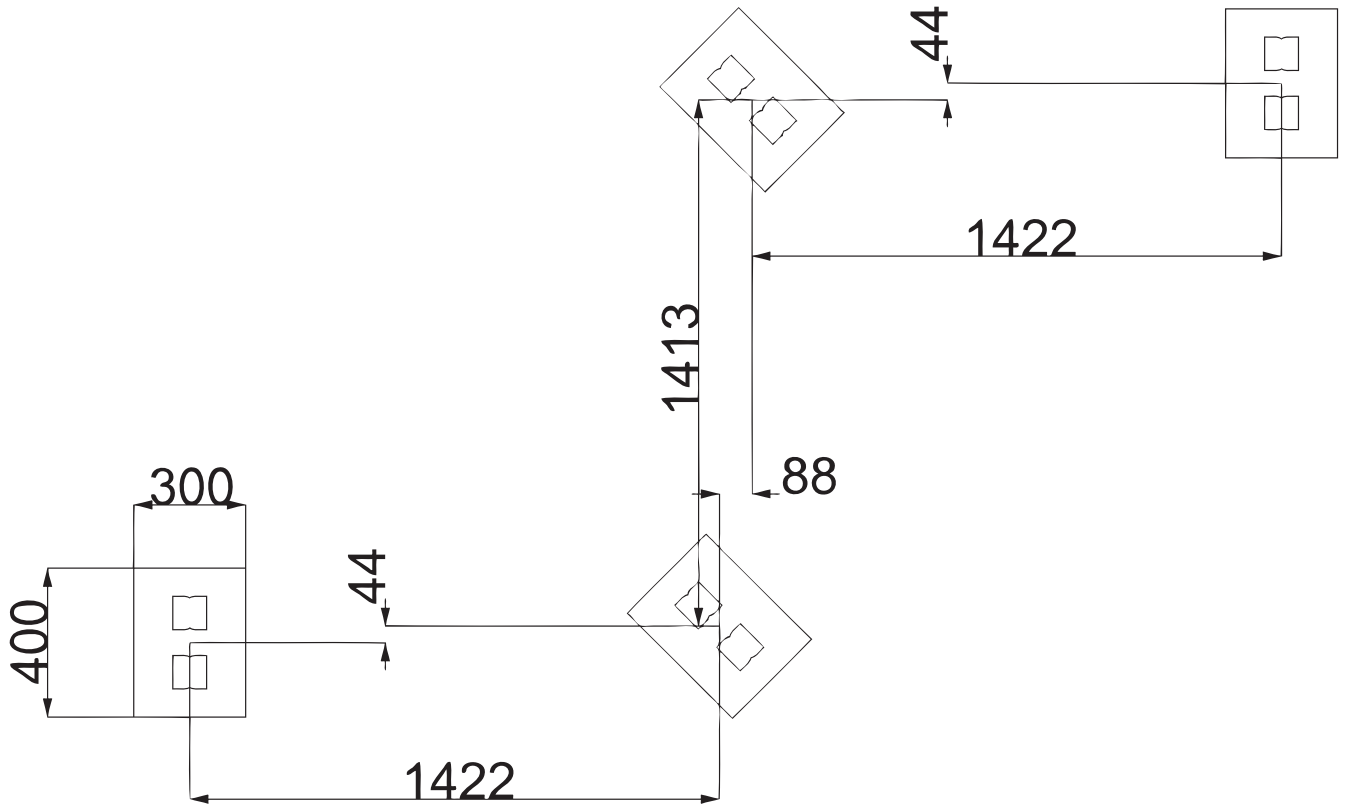

Assembly Instructions

1

If the bench IS pre-assembled follow foundation details

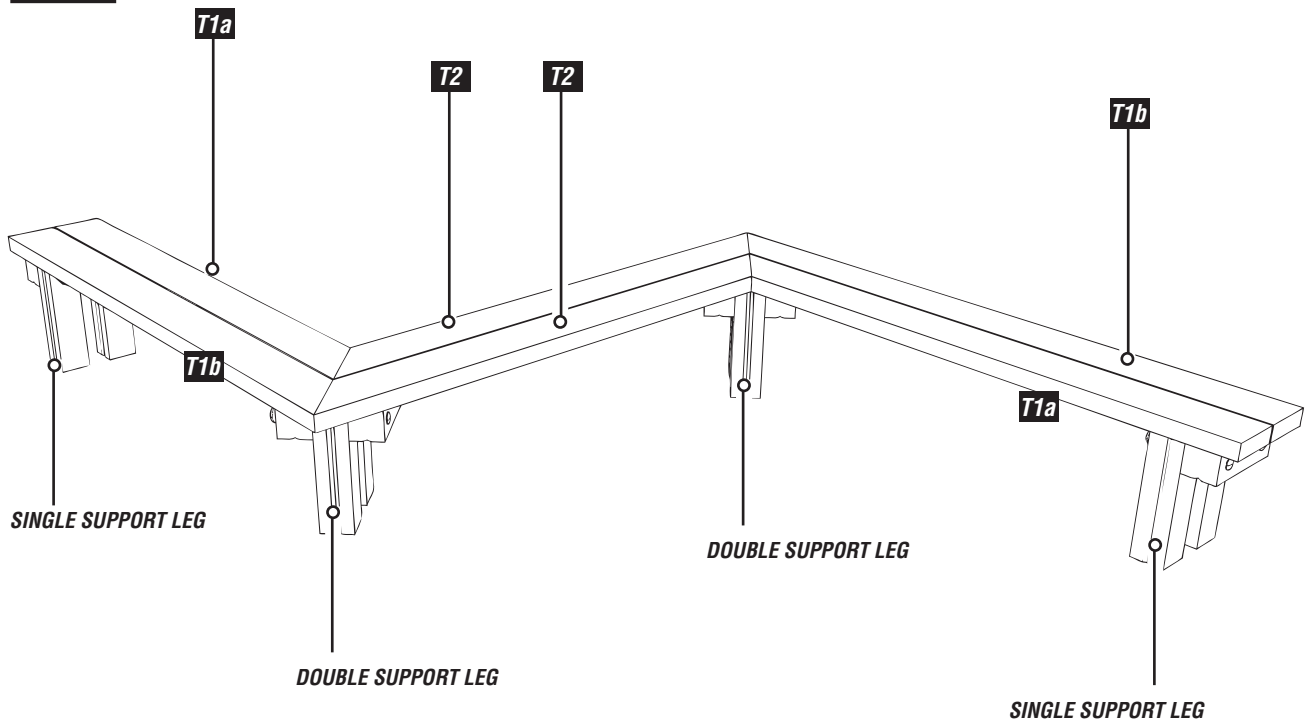

2

Attach bench slats (T1 & T2 timbers) to the support assemblies
Using 120mm brass screws

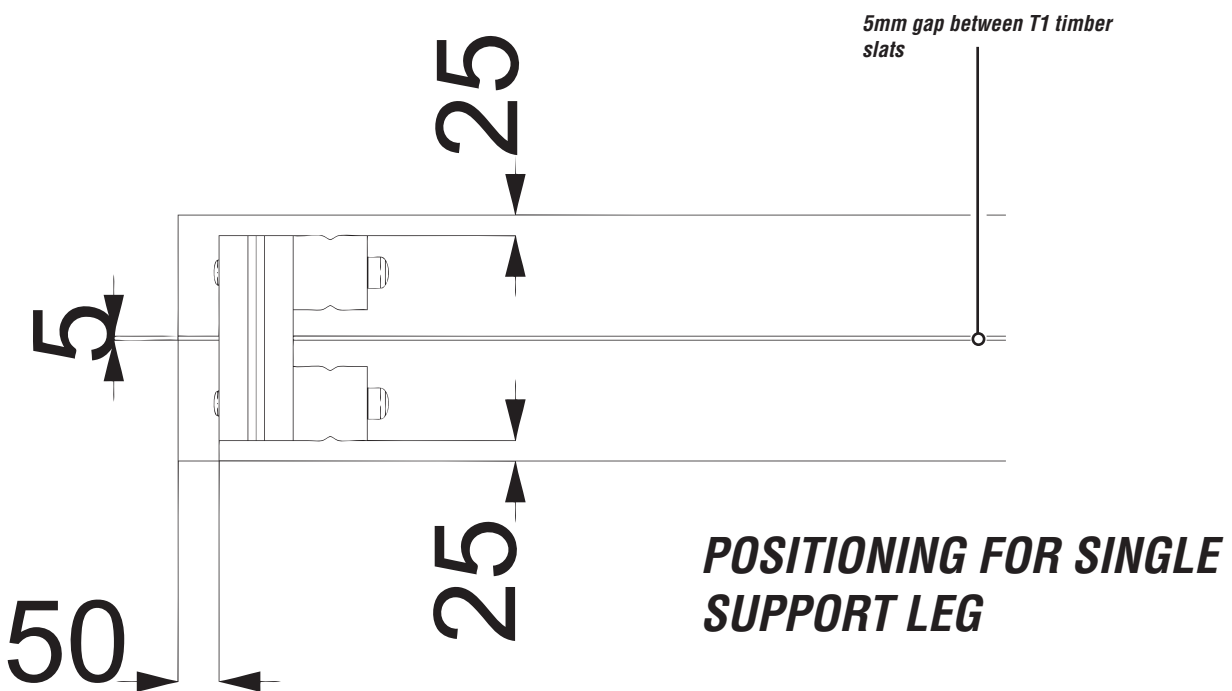

Assembly Instructions

3

Attach bench slats (T1 & T2 timbers) to the support assemblies *Continued....*

5mm gap between T1 timber slats

POSITIONING FOR DOUBLE SUPPORT LEG

25

***IMPOTANT - DASHED LINE SHOWS BOLT LOCATIONS FOR BENCH SUPPORTS - ensure the screws for the SLATS are positioned either side**

4 x 120mm brass screws for each T1 /T2 timber (2 each end)

SINGLE LEG ATTACHMENT DETAIL

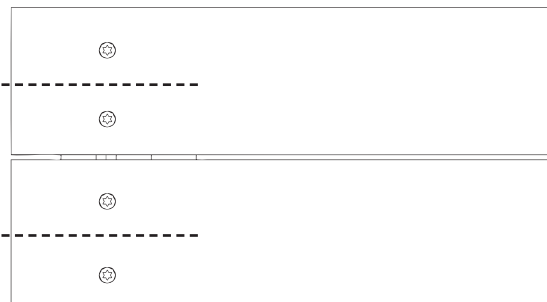

DOUBLE LEG ATTACHMENT DETAIL

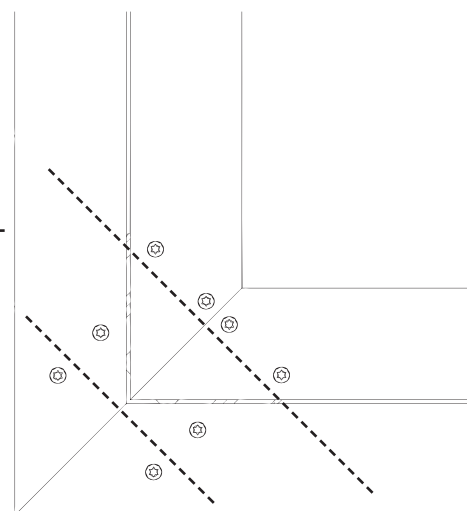

Assembly Instructions

4

Additional dimensions

