

CURVED Modular Seating Assembly Instructions

**creative
play**

4 **PIECE**

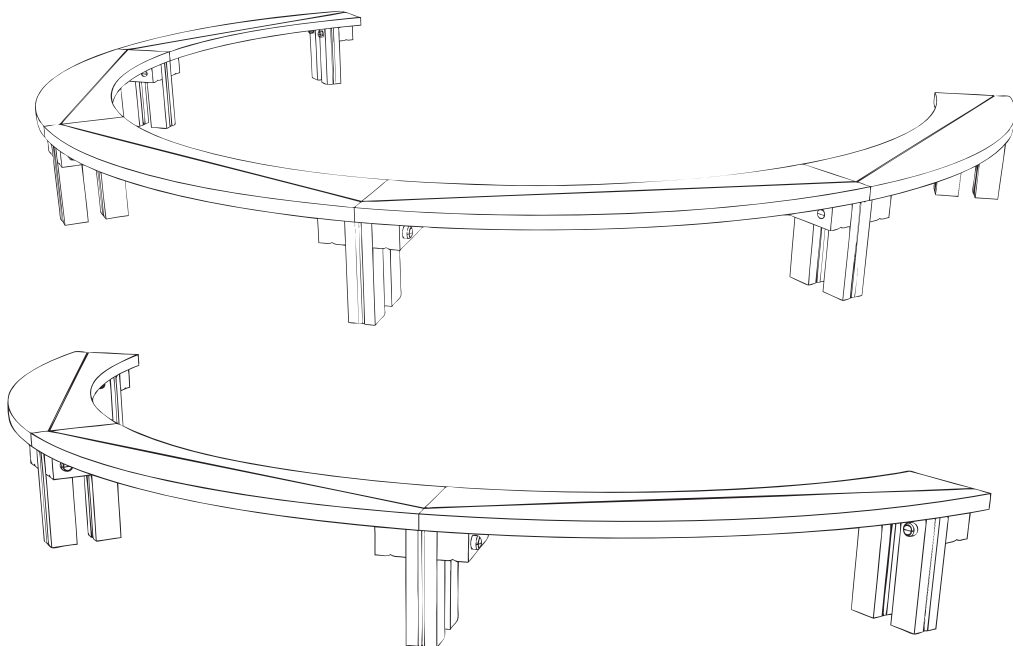
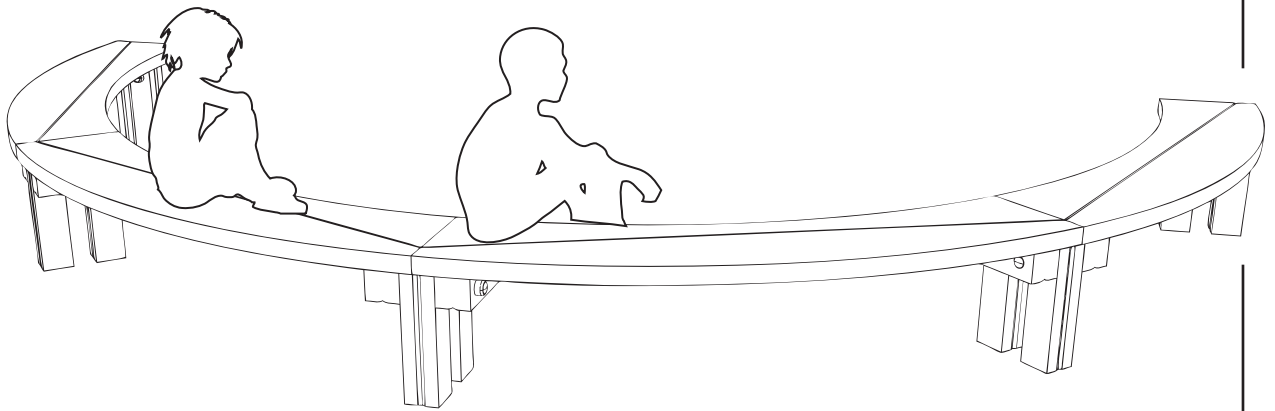

PARTS required

T1 QTY 4 (220mm x 47mm)

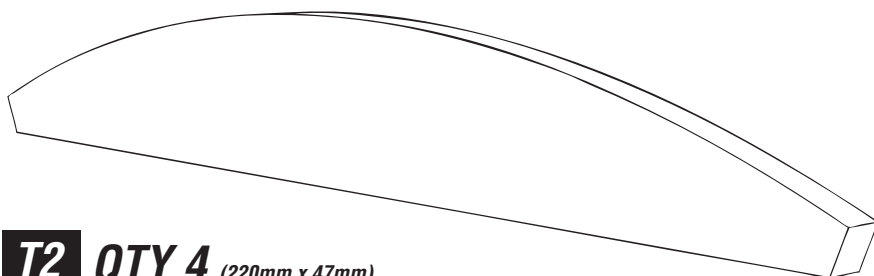

T2 QTY 4 (220mm x 47mm)

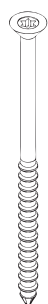
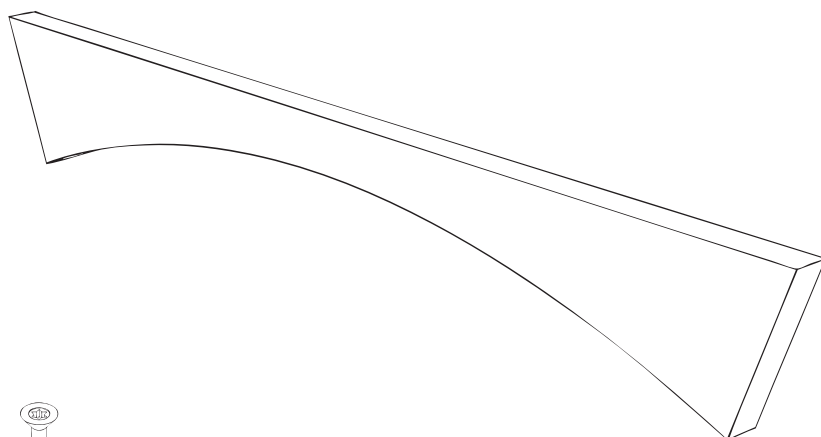

x40 (120mm brass screws)

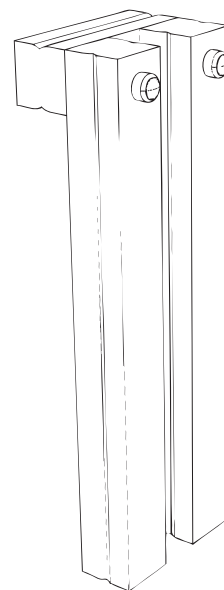

QTY 2 (single support)

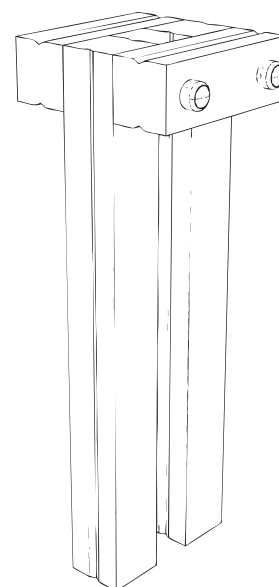

QTY 3 (double support)

TOOLS required

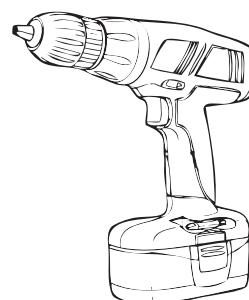
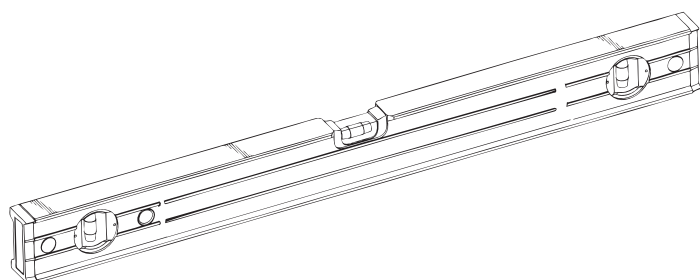

Foundation Details

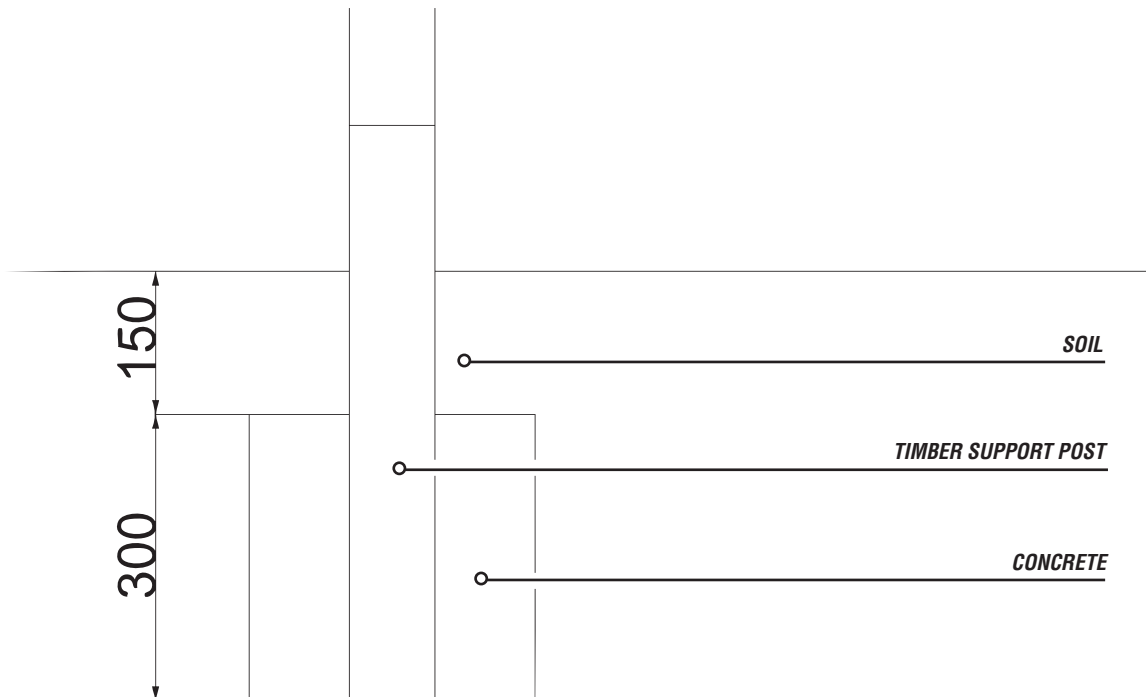
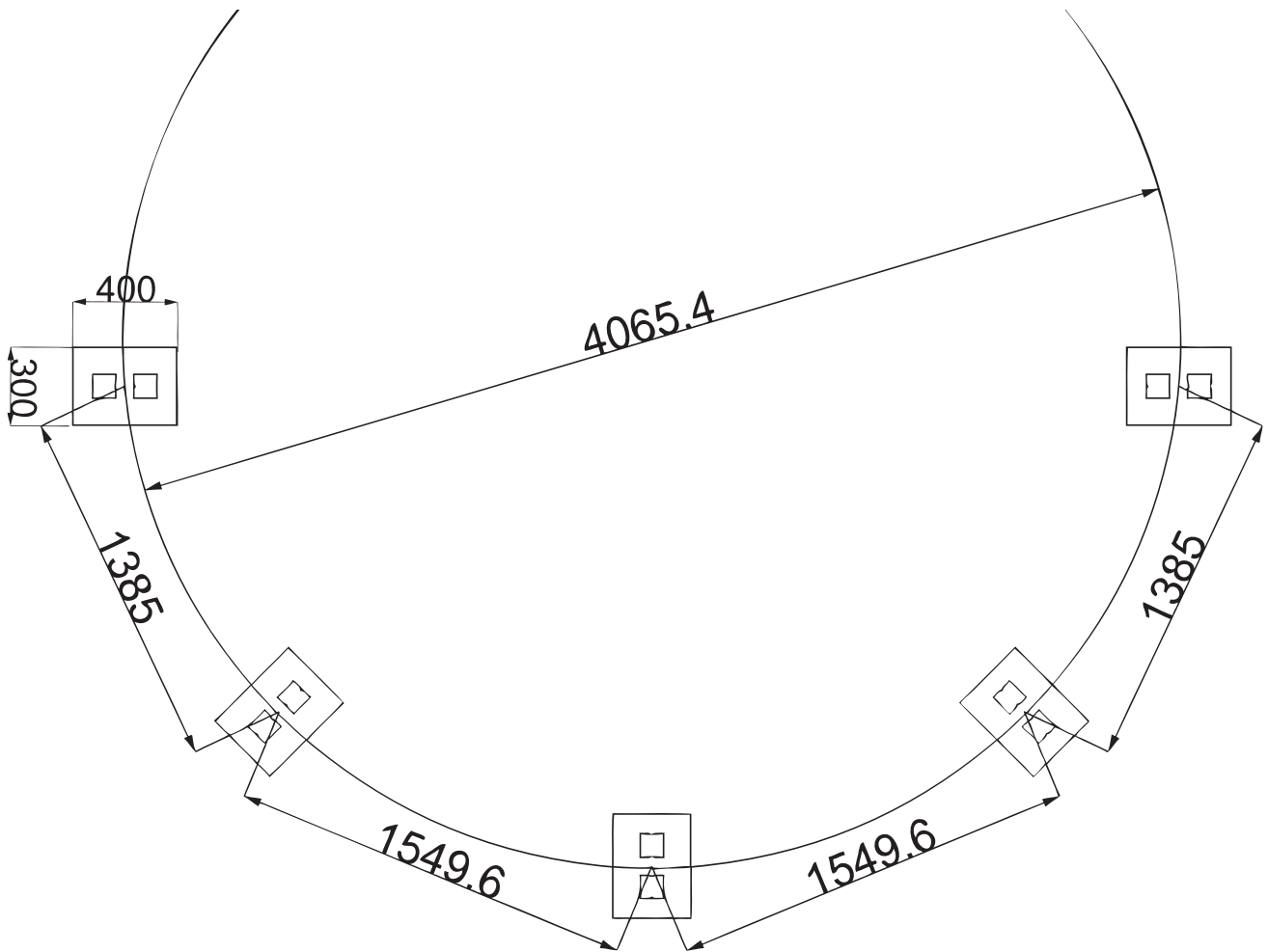

Assembly Instructions

1

4 PIECE CURVED Modular Seating

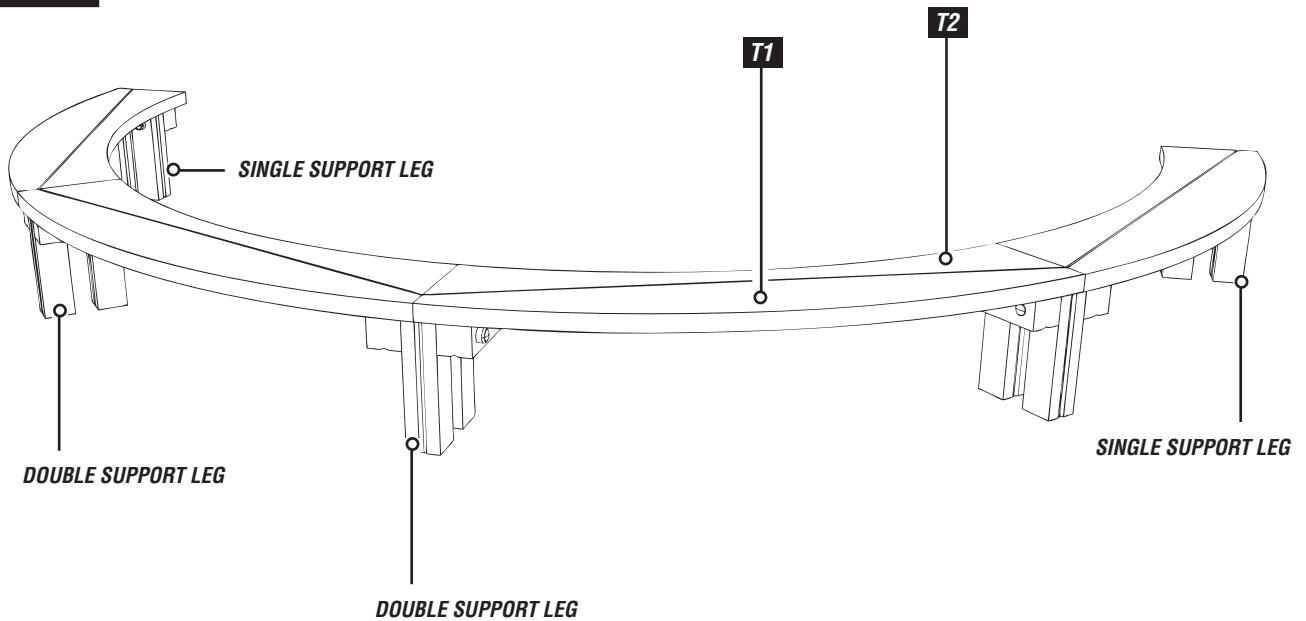

2

Attach bench slats (T1 & T2 timbers) to the support assemblies

Using 120mm brass screws

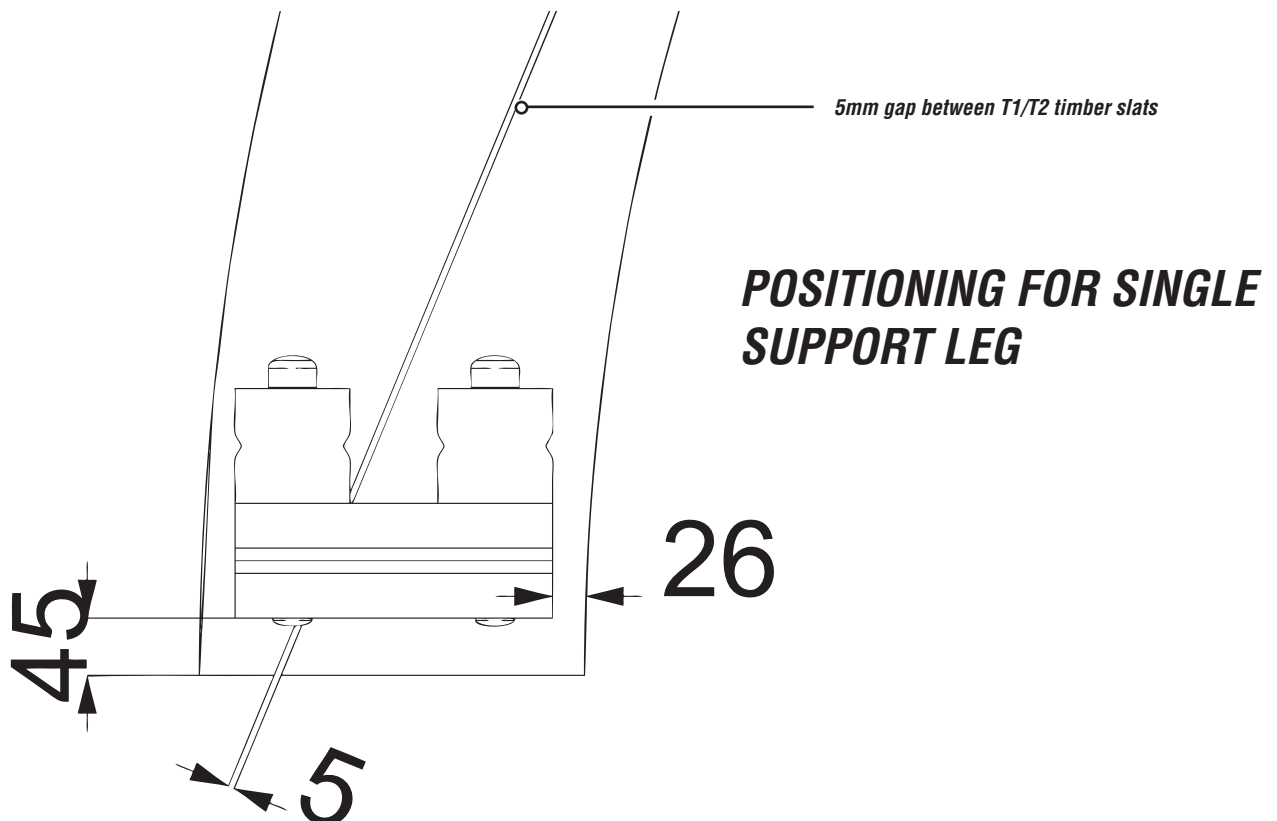

Assembly Instructions

3

Attach bench slats (T1 & T2 timbers) to the support assemblies *Continued....*

POSITIONING FOR DOUBLE SUPPORT LEG

28

5mm gap between T1 timber slats

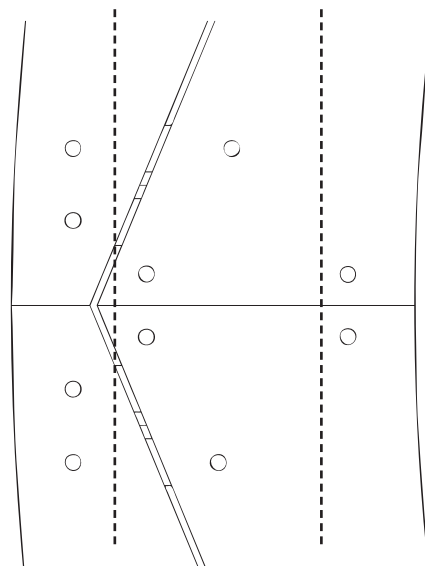
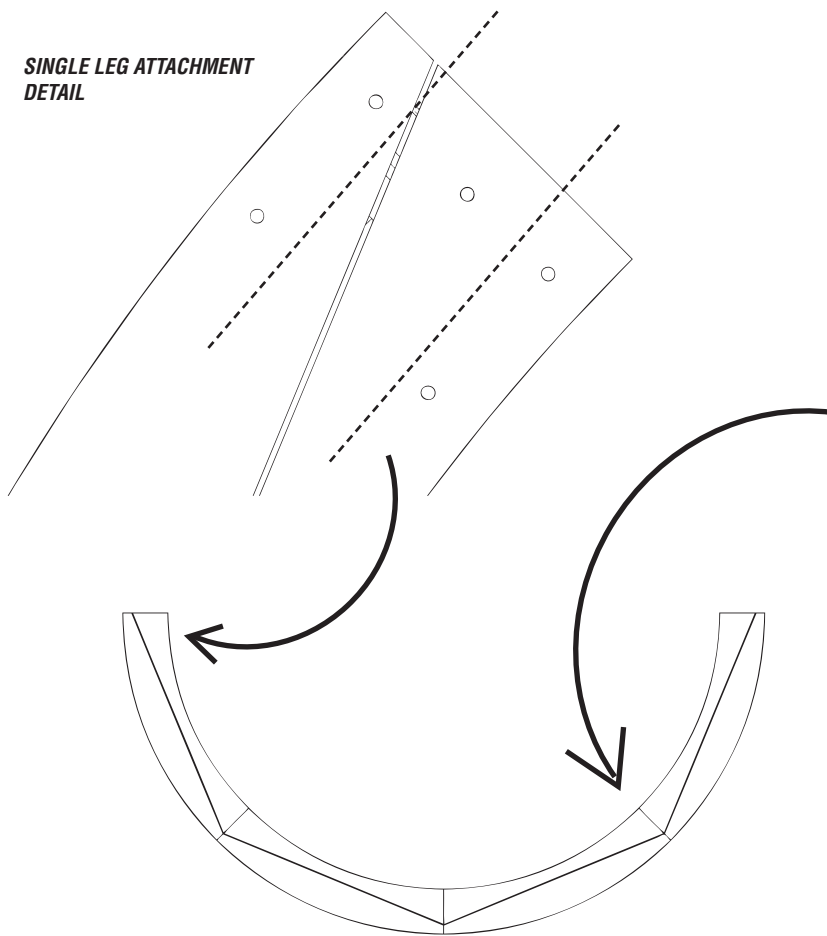

***IMPOTANT - DASHED LINE SHOWS BOLT LOCATIONS FOR BENCH SUPPORTS - ensure the screws for the SLATS are postioned either side**

Assembly Instructions

4 Additional dimensions

